

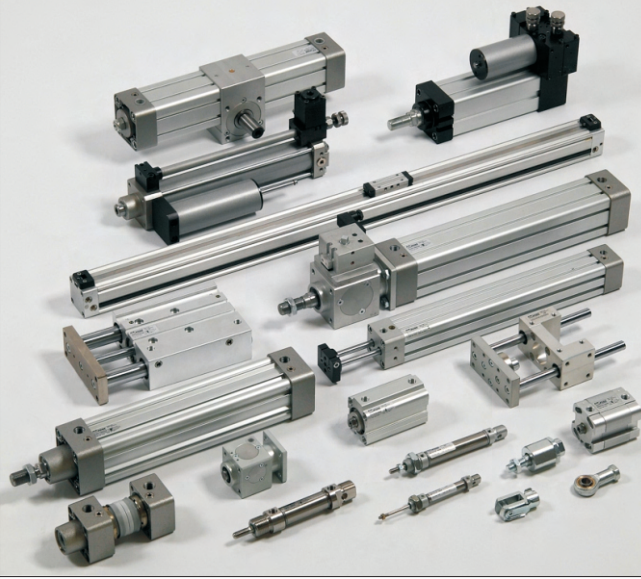

VT-HADICE&PLAST s.r.o.
Stavbárov 1
07101 Michalovce
Prevádzka Jarmočná 2, 04001 Košice
Tel. 055/6770022
Fax:055/6770022
e-mail: objednavky@vthadiceplast.sk
web: www.vthadiceplast.sk

Actuators



Valves

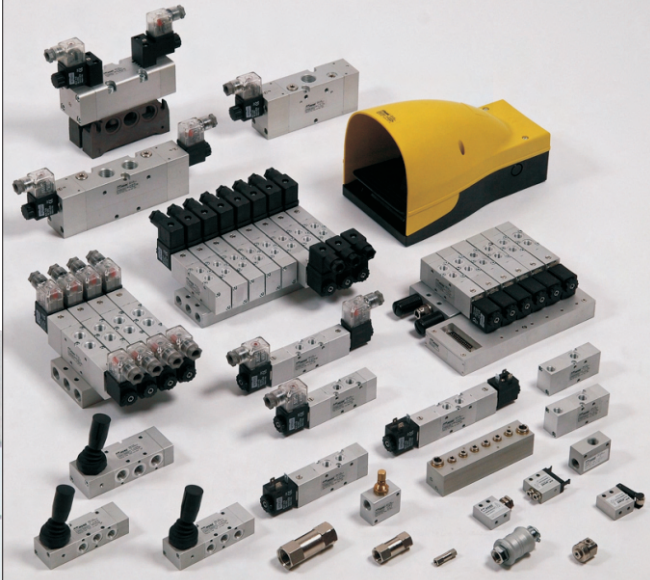

Air treatment



CILINDRI ISO 6432
CYLINDERS ISO 6432



PAGE
1.15

CILINDRI ISO 6432 - INOX
CYLINDERS ISO 6432 - STAINLESS STEEL



PAGE
1.23

CILINDRI TONDI
ROUND CYLINDERS



PAGE
1.28

CILINDRI ISO 15552- SERIE CY
CYLINDERS ISO 15552- CY SERIES



PAGE
1.35

CILINDRI ISO 15552- SERIE CZ
CYLINDERS ISO 15552- CZ SERIES



PAGE
1.36

CILINDRI ISO 15552- SERIE CQ
CYLINDERS ISO 15552- CQ SERIES



PAGE
1.41

CILINDRI AD ASTE GEMELLATE
TWIN ROD CYLINDERS



PAGE
1.43

CILINDRI COMPATTI ISO 21287
ISO 21287 COMPACT CYLINDERS



PAGE
1.45

ACCESSORI PER CILINDRI ISO 15552
ACCESSORIES FOR CYLINDERS ISO 15552



PAGE
1.49

CILINDRI ISO 15552 - INOX
CYLINDERS ISO 15552 - STAINLESS STEEL



PAGE
1.57

CILINDRI COMPATTI 125-160 -200
COMPACT CYLINDERS 125-160-200



PAGE
1.62

CILINDRI COMPATTI GUIDATI - SERIE 4
GUIDE COMPACT CYLINDERS - 4 SERIES



PAGE
1.66

CILINDRI COMPATTI GUIDATI - SERIE 6
GUIDE COMPACT CYLINDERS - 6 SERIES



PAGE
1.70

CILINDRI CORSA BREVE
SHORT STROKE CYLINDERS



PAGE
1.78

CILINDRI SENZA STELO
RODLESS CYLINDERS



PAGE
1.84

BLOCCATELO
ROD LOCK



PAGE
1.95

BLOCCATELO CON SBLOCCO MANUALE
ROD LOCK WITH MANUAL UNBLOCK

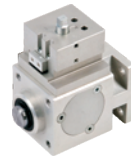

PAGE
1.99

BLOCCATELO DINAMICO
DYNAMIC ROD LOCK



PAGE
1.102

CILINDRI STOPPER
STOPPER CYLINDERS



PAGE
1.104

UNITA' DI GUIDA
GUIDE UNITS

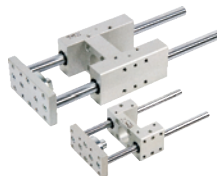

PAGE
1.108

CILINDRI ROTANTI SERIE RY
ROTARY CYLINDERS RY SERIES



PAGE
1.113

ATTUATORI ROTANTI
ROTARY ACTUATORS



PAGE
1.117

REGOLATORE IDRAULICO DI VELOCITA'
HYDRAULIC SPEED CONTROL



PAGE
1.121

CILINDRO OLEOPNEUMATICO
OIL-PNEUMATIC CYLINDER

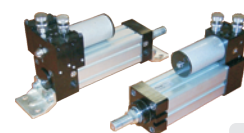

PAGE
1.131

MICROVALVOLE
MICROVALVES



PAGE
2.3

ELETTROPILOTI 15mm
SOLENOID VALVES 15mm



PAGE
2.8

ELETTROPILOTI 10mm
SOLENOID VALVES 10mm



PAGE
2.10

ELETTROVALVOLE A COMANDO DIRETTO
DIRECTLY OPERATED SOLENOID VALVES



PAGE
2.13

ELETTROVALVOLE A COMANDO DIRETTO MODULARE
MODULAR DIRECTLY OPERATED SOLENOID VALVES



PAGE
2.16

VALVOLE AD AZIONAMENTO ELETTRICO
SOLENOID ACTUATED VALVES



PAGE
2.19

SISTEMA DI CONNESSIONE MULTIPOLARE PER SERIE VY
MULTI CONNECTOR SYSTEM FOR VY SERIES

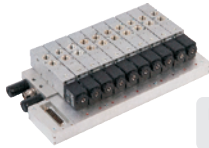

PAGE
2.35

VALVOLE AD AZIONAMENTO PNEUMATICO
PNEUMATIC ACTUATED VALVES



PAGE
2.38

VALVOLE NAMUR
NAMUR VALVES



PAGE
2.46

VALVOLE ISO 5599/1 TAGLIA 1 E 2
ISO 5599/1 VALVES - SIZE 1 AND 2



PAGE
2.50

CONNETTORI E BOBINE
COILS AND CONNECTORS



PAGE
2.32

VALVOLE AD AZIONAMENTO MANUALE
MANUAL ACTUATED VALVES



PAGE
2.55

ATTUATORI DA PANNELLO
ACTUATORS FOR PANEL MOUNTING



PAGE
2.66

VALVOLE AD AZIONAMENTO MECCANICO
MECHANICALLY ACTUATED VALVES



PAGE
2.67

VALVOLE A PEDALE
PEDAL VALVES



PAGE
2.71

REGOLATORI DI FLUSSO
FLOW REGULATORS



PAGE
2.73

REGOLATORI DI FLUSSO
FLOW REGULATORS



PAGE
2.74

VALVOLA SELETRICE
SELECTOR VALVE



PAGE
2.81

VALVOLE DI NON RITORNO
NON RETURN VALVES



PAGE
2.82

VALVOLA A SCARICO RAPIDO
QUICK EXHAUST VALVE



PAGE
2.84

VALVOLE DI BLOCCO
STOP VALVES



PAGE
2.85

PRESSOSTATI
PRESSURE SWITCHES



PAGE
2.87

TRASDUTTORE PNEUMO-ELETTRICO
PRESSURE SWITCHES



PAGE
2.88

VALVOLA A CORSOIO
SLIDE VALVE



PAGE
2.89

RUBINETTI A SFERA
BALL VALVES



PAGE
2.90

RIPARTITORI
MANIFOLDS



PAGE
2.91

SILENZIATORI
AIR SILENCERS



PAGE
2.93

FILTRI
 FILTERS



PAGE
 3.5

REGOLATORE
 REGULATOR



PAGE
 3.6

REGOLATORE SCARICO RAPIDO
 QUICK EXHAUST REGULATOR



PAGE
 3.7

REGOLATORE PER ACQUA
 WATER REGULATOR



PAGE
 3.8

FILTROREGOLATORE
 FILTER REGULATOR



PAGE
 3.9

LUBRIFICATORE
 LUBRICATOR



PAGE
 3.10

FILTROREGOLATORE+LUBRIFICATORE (FR+L)
 FILTERREGULATOR+LUBRICATOR (FR+L)



PAGE
 3.11

FILTRO+REGOLATORE+LUBRIFICATORE (F+R+L)
 FILTER+REGULATOR+LUBRICATOR (F+R+L)



PAGE
 3.12

FILTRI
 FILTERS



PAGE
 3.13

REGOLATORE
 REGULATOR



PAGE
 3.15

FILTROREGOLATORE
 FILTER REGULATOR



PAGE
 3.16

LUBRIFICATORE
 LUBRICATOR



PAGE
 3.18

FILTROREGOLATORE+LUBRIFICATORE (FR+L)
 FILTERREGULATOR+LUBRICATOR (FR+L)



PAGE
 3.20

FILTRO+REGOLATORE+LUBRIFICATORE (F+R+L)
 FILTER+REGULATOR+LUBRICATOR (F+R+L)



PAGE
 3.21

AVVIATORE PROGRESSIVO CON SCARICO RAPIDO
 SOFT START VALVE WITH QUICK EXHAUST

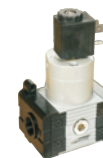

PAGE
 3.22

VALVOLA SELETRICE
 SHOT OFF VALVE



PAGE
 3.23

FILTRO + LUBRIFICATORE (F+L)
 FILTER + LUBRICATOR (F+L)



PAGE
 3.25

VALVOLA+FILTROREGOLATORE+LUBRIFICATORE (V+FR+L)
 VALVE+FILTREGULATOR+LUBRICATOR (V+FR+L)



PAGE
 3.26

VALVOLA+FILTRO+REGOLATORE+LUBRIFICATORE (V+F+R+L)
 VALVE+FILTER+REGULATOR+LUBRICATOR (V+F+R+L)



PAGE
 3.27

STAFFA DI FISSAGGIO
 CLAMP BRACKET



PAGE
 3.28

MANOMETRO
 MANOMETER



PAGE
 3.28

FLUIDO

I cilindri AIR WORK sono progettati per funzionare con aria non lubrificata, ciò vuol dire che i componenti assemblati ricevono una lubrificazione di base in grado di garantire il corretto funzionamento.

Se si decide di utilizzare aria lubrificata è importante che sia continua, perché la lubrificazione dell'aria asporta quella applicata all'interno del prodotto in fase di montaggio.

FLUID

AIR WORK cylinders are designed in order to work with not lubricated air, the components are normally pre lubricated in order to guarantee a correct functioning.

If it is necessary to use lubricated air, it is important that the flow is continuous: in fact successive lubrication removes the one applied previously inside the cylinder.

I PARAMETRI / PARAMETERS

Alesaggio: diametro interno del tubo (mm) / Size: inside diameter of the tube (mm)

Corsa: Traslazione di lavoro (mm) / Stroke: Translation of work (mm)

Pressione di funzionamento: (bar) / Operating Pressure: (bar)

Temperatura di funzionamento: (C°) / Operating temperature: (C°)

Velocità di traslazione: (m/s) / Speed of translation: (m/s)

Forza di ammortizzo: (Nm) / Cushioning force: (Nm)

Consumo d'aria: (nl/min) / Air consumption: (nl/min)

Forza teorica: (N) / Theoretical force: (N)

CORSE SUPERIORI

I clienti possono richiedere cilindri con corse superiori a quelle indicate sul catalogo.

E' cura e responsabilità del cliente impiegare correttamente questi cilindri fuori standard, cercando il piu' possibile di guidare lo stelo evitando carichi anomali.

NON STANDARD STROKES

We will welcome any request coming from our customers concerning strokes not indicated in the catalogue. In this case, it is particular responsibility of the customer to use correctly these not standard cylinders, trying as much as possible to guide the rod and avoiding anomalous loads.

Consumo d'aria in spinta e in trazione in Nl/cm di corsa, in funzione della pressione (bar) a 20°C
Air's consumption push/traction Nl/cm by stroke, in function of pressure (bar) at 20°C

Ø Cil. Ø Cyl.	Ø Stelo Ø rod		Area cm ²	1bar	2bar	3bar	4bar	5bar	6bar	7bar	8bar	9bar	10bar
12	6	Spinta/Push	1,13	0,0023	0,0034	0,0045	0,0057	0,0068	0,0079	0,0090	0,0102	0,0113	0,0124
		Trazione/Traction	1,00	0,0016	0,0025	0,0033	0,0042	0,0050	0,0059	0,0067	0,0076	0,0084	0,0093
16	6	Spinta/Push	2,01	0,0040	0,0060	0,0080	0,0100	0,0121	0,0141	0,0161	0,0181	0,0202	0,0221
		Trazione/Traction	1,73	0,0035	0,0052	0,0069	0,0086	0,0104	0,0121	0,0138	0,0156	0,0173	0,0190
20	8	Spinta/Push	3,14	0,0063	0,0094	0,0126	0,0157	0,0188	0,0220	0,0251	0,0283	0,0314	0,0346
		Trazione/Traction	2,64	0,0053	0,0079	0,0106	0,0132	0,0158	0,0185	0,0211	0,0238	0,0264	0,0290
25	10	Spinta/Push	4,91	0,0098	0,0147	0,0196	0,0245	0,0295	0,0344	0,0393	0,0442	0,0491	0,0540
		Trazione/Traction	3,78	0,0076	0,0113	0,0151	0,0189	0,0227	0,0264	0,0302	0,0340	0,0378	0,0415
32	12	Spinta/Push	8,04	0,016	0,024	0,032	0,040	0,048	0,056	0,064	0,072	0,080	0,088
		Trazione/Traction	6,91	0,014	0,021	0,028	0,035	0,042	0,049	0,058	0,063	0,070	0,076
40	16	Spinta/Push	12,57	0,025	0,038	0,050	0,063	0,075	0,088	0,101	0,113	0,126	0,138
		Trazione/Traction	10,56	0,021	0,032	0,042	0,053	0,063	0,074	0,084	0,095	0,106	0,116
50	20	Spinta/Push	19,63	0,039	0,059	0,079	0,098	0,118	0,137	0,157	0,177	0,196	0,216
		Trazione/Traction	16,49	0,033	0,049	0,066	0,082	0,099	0,115	0,132	0,148	0,165	0,181
63	20	Spinta/Push	31,17	0,062	0,094	0,125	0,156	0,187	0,218	0,249	0,281	0,312	0,343
		Trazione/Traction	28,03	0,056	0,084	0,112	0,140	0,168	0,196	0,224	0,252	0,280	0,308
80	25	Spinta/Push	50,24	0,101	0,151	0,201	0,251	0,302	0,352	0,402	0,452	0,503	0,553
		Trazione/Traction	45,36	0,091	0,136	0,181	0,227	0,272	0,317	0,363	0,408	0,454	0,499
100	25	Spinta/Push	78,54	0,157	0,236	0,314	0,393	0,471	0,550	0,628	0,707	0,785	0,864
		Trazione/Traction	70,50	0,147	0,221	0,295	0,368	0,442	0,515	0,589	0,663	0,736	0,810
125	32	Spinta/Push	122,72	0,245	0,368	0,490	0,613	0,736	0,859	0,981	1,104	1,226	1,349
		Trazione/Traction	114,68	0,229	0,344	0,459	0,573	0,688	0,803	0,917	1,032	1,147	1,262
160	40	Spinta/Push	201,06	0,402	0,603	0,804	1,005	1,206	1,407	1,608	1,809	2,010	2,211
		Trazione/Traction	188,5	0,377	0,565	0,754	0,942	1,130	1,319	1,508	1,696	1,884	2,073
200	40	Spinta/Push	314,16	0,628	0,942	1,257	1,571	1,885	2,199	2,513	2,827	3,145	3,456
		Trazione/Traction	301,59	0,603	0,905	1,206	1,508	1,810	2,111	2,413	2,714	3,016	3,318

Forza in spinta e trazione in daN in funzione della pressione (bar)
Forces in push and traction in daN in function of the pressure (bar).

Ø Cil. Ø Cyl.	Ø Stelo Ø rod		Area utile cm ²	1bar	2bar	3bar	4bar	5bar	6bar	7bar	8bar	9bar	10bar
8	4	Spinta/Push	0,50	0,5	1,0	1,5	2,0	2,5	3,0	3,5	4,0	4,5	5,0
		Trazione/Traction	0,38	0,4	0,8	1,1	1,5	1,9	2,3	2,6	3,0	3,4	3,8
10	4	Spinta/Push	0,79	0,8	1,6	2,4	3,1	3,9	4,7	5,5	6,3	7,1	7,9
		Trazione/Traction	0,66	0,7	1,3	2,0	2,6	3,3	4,0	4,6	5,3	5,9	6,6
12	6	Spinta/Push	1,13	1,1	2,3	3,4	4,5	5,7	6,8	7,9	9,0	10,2	11,3
		Trazione/Traction	0,85	0,8	1,7	2,5	3,4	4,2	5,1	5,9	6,8	7,6	8,5
16	6	Spinta/Push	2,01	2,0	4,0	6,0	8,0	10,1	12,1	14,1	16,1	18,1	20,1
		Trazione/Traction	1,73	1,7	3,5	5,2	6,9	8,6	10,4	12,1	13,8	15,6	17,3
20	8	Spinta/Push	3,14	3,1	6,3	9,4	12,6	15,7	18,8	22,0	25,1	28,3	31,4
		Trazione/Traction	2,64	2,6	5,3	7,9	10,6	13,2	15,8	18,5	21,1	23,8	26,4
25	10	Spinta/Push	4,91	4,9	9,8	14,7	19,6	24,5	29,5	34,4	39,3	44,2	49,1
		Trazione/Traction	4,12	4,1	8,2	12,4	16,5	20,6	24,7	28,9	33,0	37,1	41,2
32	12	Spinta/Push	8,04	8	16,1	24,1	32,2	40,2	48,3	56,3	64,3	72,4	80,4
		Trazione/Traction	6,91	6,9	13,8	20,7	27,6	34,6	41,5	48,4	55,3	62,2	69,1
40	16	Spinta/Push	12,57	12,6	25,1	37,7	50,3	62,8	75,4	88	100,5	113,1	125,7
		Trazione/Traction	10,56	10,6	21,1	31,7	42,2	52,8	63,3	73,9	84,4	95,0	105,6
50	20	Spinta/Push	19,63	19,6	39,3	58,9	78,5	98,2	117,8	137,4	157,1	176,7	196,3
		Trazione/Traction	16,49	16,5	33,0	49,5	66,0	82,5	99,0	115,5	131,9	148,4	164,9
63	20	Spinta/Push	31,17	31,2	62,3	93,5	124,7	155,9	187,0	218,2	249,4	280,6	311,7
		Trazione/Traction	28,03	28,0	56,1	84,1	112,1	140,2	168,2	196,2	224,2	252,3	280,3
80	25	Spinta/Push	50,24	50,3	100,5	150,8	201,1	251,3	301,6	351,9	402,1	452,4	502,7
		Trazione/Traction	45,36	45,4	90,7	136,1	181,4	226,8	272,1	317,5	362,9	408,2	453,6
100	25	Spinta/Push	78,54	78,5	157,1	235,6	314,2	392,7	471,2	549,8	628,3	706,9	785,4
		Trazione/Traction	73,63	73,6	147,3	220,9	294,5	368,2	441,8	515,4	589,0	662,7	736,3
125	32	Spinta/Push	122,72	122,7	245,4	368,2	490,9	613,6	736,3	859,0	981,7	1104,5	1227,2
		Trazione/Traction	114,68	114,7	229,4	344,0	458,7	573,4	688,1	802,7	917,4	1032,1	1146,8
160	40	Spinta/Push	201,06	201,1	402,1	603,2	804,2	1005,3	1206,4	1407,4	1608,5	1809,6	2010,6
		Trazione/Traction	188,5	188,5	377,0	565,5	754,0	942,5	1131,0	1319,5	1508,0	1696,5	1885,0
200	40	Spinta/Push	314,16	314,2	628,3	942,5	1256,6	1570,8	1885,0	2199,1	2513,3	2827,4	3141,6
		Trazione/Traction	301,59	301,6	603,2	904,8	1206,4	1508,0	1809,6	2111,1	2412,7	2714,3	3015,9

Carico ammortizzabile/ Amortizable load





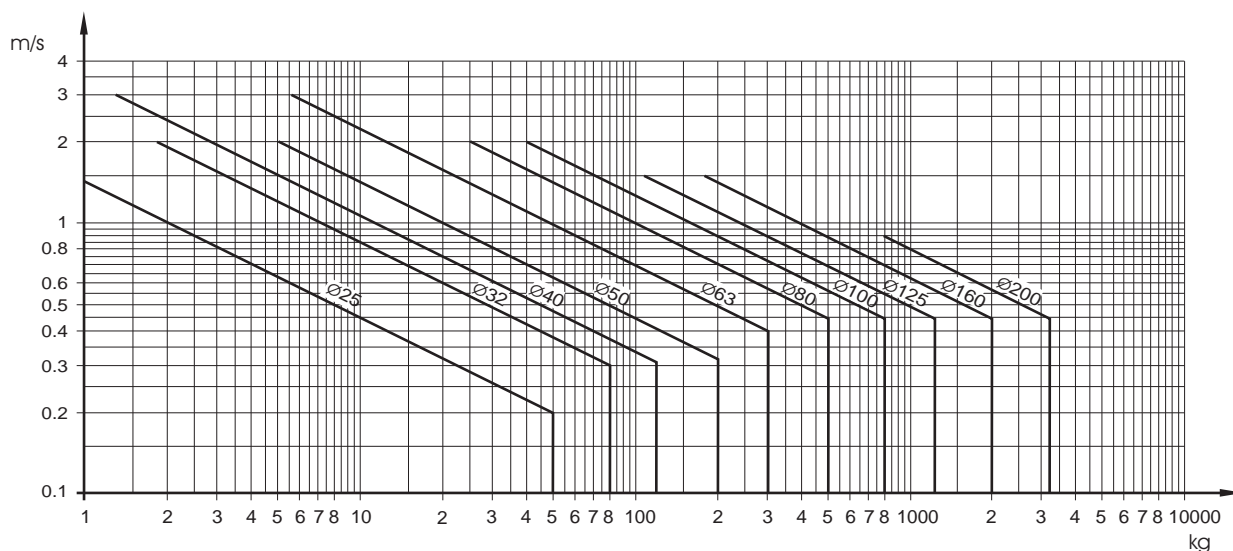













Affinché il cilindro raggiunga la posizione di fine corsa senza urti dannosi, occorre annullare l'energia cinetica della massa in movimento ed il relativo lavoro sviluppato. Il valore massimo del carico ammortizzabile dipende dalla velocità di traslazione e dalla capacità di assorbimento dell'ammortizzo pneumatico dei cilindri. Il diagramma fornisce i valori di velocità, massa ammortizzabile ad una pressione di 6 bar.









To make cylinder reach its end run position without dangerous hits, it's necessary to annul kinetic energy and relative work produced by moving mass. The maximum value of amortizable load depends on translation speed and absorbance capability of pneumatic cushioning of cylinders. The chart below provides values of speed and amortizable mass for a pressure of 6 bar.



	Fonte di pressione pneumatica Font of pneumatic pressure
	Linea Line
	Linea di pilotaggio Line of pilotage
	Linea di scarico Line of axhaust
	Linea flessibile Flexible line
	Linea elettrica Electric line
	Collegamento di linee Connection of lines
	Incrocio di linee Intersection of lines
	Scarico d'aria connessione non filettata Exhaust of air connection not filleted
	Scarico d'aria connessione filettata Exhaust of air filleted connection
	Presa d'aria tappata Air intake with plug
	Punto di prelievo con attacco Point of collecting with attack
	Innesto rapido senza valvola di non ritorno Quick coupling without non-return valve
	Innesto rapido con valvola di non ritorno Quick coupling with non-return valve
	Innesto rapido con terminale chiusa Quick coupling with terminal closed
	Innesto rapido con terminale aperto Quick coupling with terminal open
	Serbatoio Tank
	Manometro Pressure gauge

	Valvola a 2 vie - 2 posizioni normalmente chiusa Valve in 2 way - 2 positions, normally closed
	Valvola a 2 vie - 2 posizioni normalmente aperta Valve in 2 way - 2 positions, normally open
	Valvola a 3 vie - 2 posizioni normalmente chiusa Valve in 3 way - 2 positions, normally closed
	Valvola a 3 vie - 2 posizioni normalmente aperta Valve in 3 way - 2 positions, normally open
	Valvola a 5 vie - 2 posizioni Valve in 5 way - 2 positions
	Valvola a 5 vie - 3 posizioni centri chiusi Valve in 5 way - 3 positions closed centers
	Valvola a 5 vie - 3 posizioni centri aperti Valve in 5 way - 3 positions open centers
	Valvola a 5 vie - 3 posizioni centri in pressione Valve in 5 way - 3 positions pressure centers
	Valvola a scarico rapido Quick exhaust valve
	Valvola selettiva di circuito (elemento OR) Quick exhaust valve (OR)
	Valvola di non ritorno con molla Non-return valve
	Valvola unidirezionale Uni-directional valve
	Silenziatore Silencer
	Regolatore di flusso bidirezionale Flow control bi-directional valve
	Regolatore di flusso unidirezionale Flow control uni-directional valve
	Riduttore di pressione senza valvola di scarico Pressure control without exhaust valve
	Riduttore di pressione con valvola di scarico (Relieving) Pressure control with exhaust valve
	Riduttore di pressione pilotato con valvola di scarico (Relieving) Piloted pressure control with exhaust valve

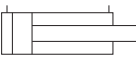
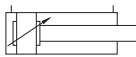
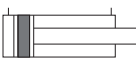
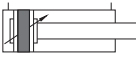
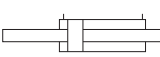
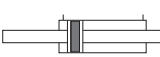
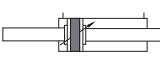
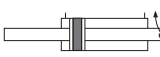
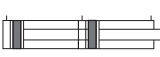
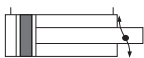
	Azionamento manuale generico Manual actuated
	Azionamento manuale a pulsante Manual actuated to button
	Azionamento manuale a leva Manual actuated to lever
	Azionamento manuale a leva a 2 posizioni Manual actuated to lever to 2 positions
	Azionamento manuale a leva a 3 posizioni Manual actuated to lever to 3 positions
	Azionamento manuale a pedale Pedal actuated
	Azionamento meccanico a puntale servopilotato Mechanically actuated to servo-piloted tappet
	Azionamento meccanico a puntale Mechanically actuated to tappet
	Azionamento meccanico a molla Mechanically actuated to spring
	Azionamento meccanico a leva rullo Mechanically actuated to roller lever
	Azionamento meccanico a leva rullo unidirezionale Mechanically actuated to uni-directional lever
	Azionamento elettro-pneumatico Elettro-pneumatic actuated
	Azionamento elettrico Electric actuated
	Azionamento elettro-pneumatico asservito Elettro-pneumatic actuated separate air supply
	Azionamento pneumatico Pneumatic actuated
	Filtro Filter
	Separatore di condensa a scarico manuale Water trap to manual exhaust
	Separatore di condensa a scarico automatico Water trap to automatic exhaust

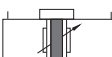
	Filtro per separatore di condensa a scarico manuale Filter for water trap to manual exhaust
	Filtro per separatore di condensa a scarico automatico Filter for water trap to automatic exhaust
	Lubrificatore Lubricator
	Valvola di intercettazione Interception valve
	Pressostato Pressure switch
	Cilindro semplice effetto Single acting cylinder
	Cilindro doppio effetto Double acting cylinder
	Cilindro doppio effetto ammortizzato Double acting cushioning cylinder
	Cilindro doppio effetto magnetico Double acting magnetic cylinder
	Cilindro doppio effetto magnetico ammortizzato Double acting magnetic cushioning cylinder
	Cilindro doppio effetto stelo passante Double acting through rod cylinder
	Cilindro doppio effetto magnetico stelo passante Double acting magnetic through rod cylinder
	Cilindro doppio effetto magnetico stelo passante ammortizzato Double acting magnetic through rod cushioning cylinder
	Cilindro doppio effetto magnetico stelo passante antirotazione Double acting magnetic through rod non rotating cylinder
	Cilindro doppio effetto magnetico tandem Double acting magnetic tandem cylinder
	Cilindro doppio effetto magnetico dispositivo antirotazione Double acting magnetic non-rotating
	Cilindro rotante con regolazione angolo Rotary cylinder with adjustment of rotation
	Cilindro senza stelo doppio effetto magnetico ammortizzato Double acting magnetic cushioning rodless cylinder



I microcilindri AIRWORK sono realizzati secondo le normative europee DIN/ISO 6432 ed hanno alesaggi compresi tra 8 e 25 mm. Le testate sono fissate alla carnicia mediante rullatura. Sono realizzabili in differenti versioni, semplice / doppio effetto, magnetici, Ammortizzati. Sono inoltre disponibili i relativi accessori di fissaggio ed esecuzioni speciali a disegno.

AIRWORK microcylinders ISO 6432 series MC are manufactured following European norms DIN/ISO 6432 and have bores comprised between 8 and 25 mm. The cap heads are fixed to the tube through a process of rolling. They are available in different versions, single / double effect, magnetic, cushioned. A complete range of fixing accessories is available, and the production of special cylinders on customer's drawing is also possible.

CHIAVE DI CODIFICA / KEY TO TYPE NUMBER

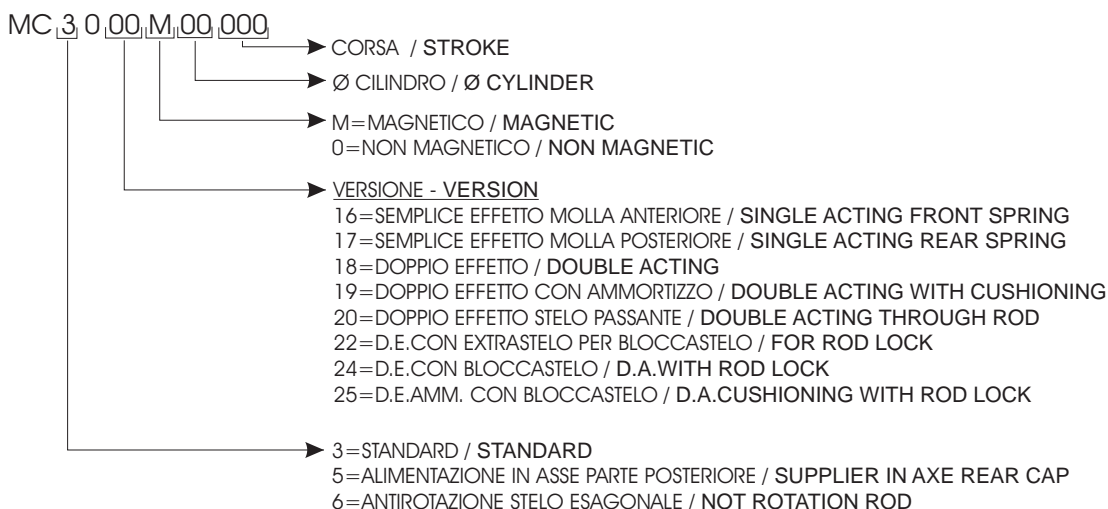

VERSIONE - VERSION

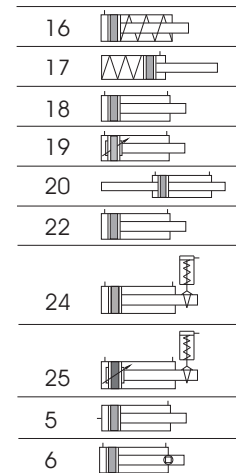

CORSE STANDARD - STANDARD STROKES

Doppio effetto - Double acting

Ø8	mm10-25-50-80-100-125
Ø10	mm10-25-50-80-100-125
Ø12	mm10-25-50-80-100-125-160-200
Ø16	mm10-25-50-80-100-125-160-200-250
Ø20	mm10-25-50-80-100-125-160-200-250-320
Ø25	mm10-25-50-80-100-125-160-200-250-320

Ammortizzato - Cushioning

Ø16	mm10-25-50-80-100-125-160-200-250
Ø20	mm10-25-50-80-100-125-160-200-250-320
Ø25	mm10-25-50-80-100-125-160-200-250-320

Semplice effetto - Single acting

Ø8	mm10-25-50
Ø10	mm10-25-50
Ø12	mm10-25-50
Ø16	mm10-25-50
Ø20	mm10-25-50
Ø25	mm10-25-50

DATI TECNICI / TECHNICAL DATA

Fluido - Fluid	Aria con o senza lubrificazione - Lubricated or non lubricated air
Temperatura di esercizio - Operating temperature range	-20C° / +80C°
Pressione massima di esercizio - Max operating pressure	10 bar
Forze sviluppate - Force	pag.dati tecnici / technical informations page
Consumo aria - Air consumption	pag.dati tecnici / technical informations page

COMPONENTI / COMPONENTS

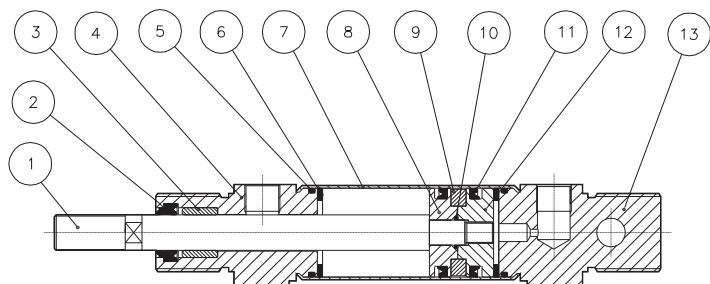

pos.	descrizione / description	materiale / material
1	stelo / rod	acciaio inox 303 / stainless steel AISI 303
2	guarnizione stelo / rod seal	poliuretano / polyurethane
3	bussola guida / guide bush	bronzo / bronze
4	testata anteriore / front cap	alluminio / aluminium
5	o-ring	NBR
6	paracolpo / bumper	neoprene
7	tubo / tube	acciaio inox 304 / stainless steel AISI 304
8	pistone / piston	ot 58
9	magnete / magnet	plastroferrite
10	o-ring	NBR
11	guarnizione pist. / seal piston	poliuretano / polyurethane
12	pistone / piston	ot 58
13	testata posteriore / rear cap	alluminio / aluminium

DOPPIO EFFETTO
DOUBLE ACTING

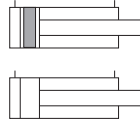

SEMPLICE EFFETTO
SINGLE ACTING

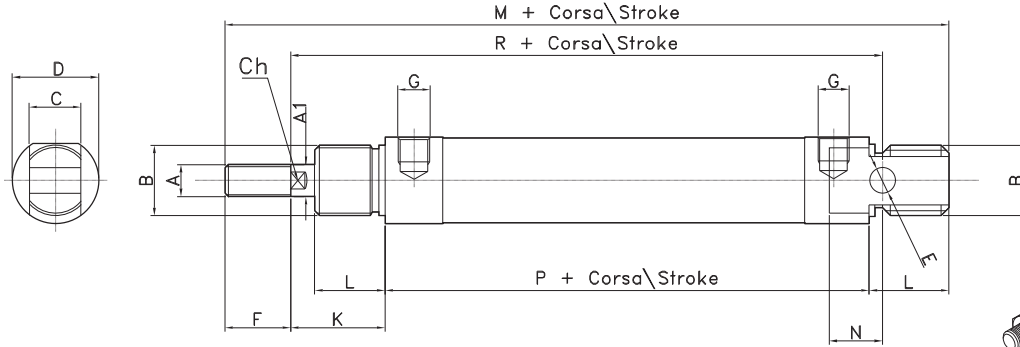
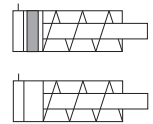

Ø	A	A1	B	C	D	E	F	G	K	L	M	N	P	R	CH
8	M4	4	M12x1.25	8	16	4	12	M5	16	12	86	6	46	64	-
10	M4	4	M12x1.25	8	16	4	12	M5	16	12	86	6	46	64	-
12	M6	6	M16x1.5	12	19	6	16	M5	22	18	104	9	48	75	5
16	M6	6	M16x1.5	12	19	6	16	M5	22	18	109	9	53	82	5
20	M8	8	M22x1.5	16	27	8	20	1/8 G	24	20	131	12	67	95	7
25	M10x1.25	10	M22x1.5	16	30	8	22	1/8 G	28	22	140	12	68	104	9

STELO PASSANTE
THROUGH ROD

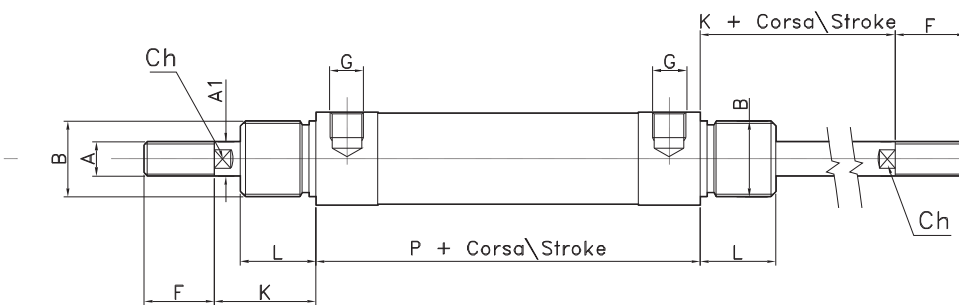
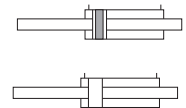

Ø	A	A1	B	D	F	K	L	P	G	CH
8	M4	4	M12x1.25	16	12	16	12	46	M5	-
10	M4	4	M12x1.25	16	12	16	12	46	M5	-
12	M6	6	M16x1.5	19	16	22	18	48	M5	5
16	M6	6	M16x1.5	19	16	22	18	53	M5	5
20	M8	8	M22x1.5	27	20	24	20	67	1/8 G	7
25	M10x1.25	10	M22x1.5	30	22	28	22	68	1/8 G	9

AMMORTIZZATO
CUSHIONING

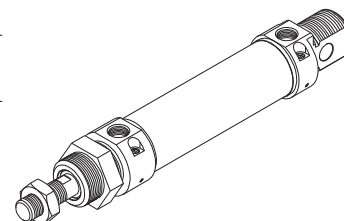
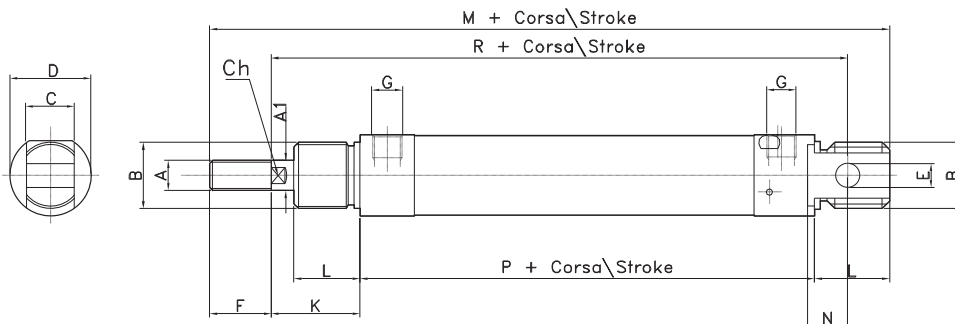
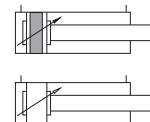

Ø	A	A1	B	C	D	E	F	G	K	L	M	N	P	R	CH
16	M6	6	M16x1.5	12	21	6	16	M5	22	18	109	9	53	82	5
20	M8	8	M22x1.5	16	27	8	20	1/8 G	24	20	131	12	67	95	7
25	M10x1.25	10	M22x1.5	16	30	8	22	1/8 G	28	22	140	12	68	104	9

SEMPLICE EFFETTO
SINGLE ACTING

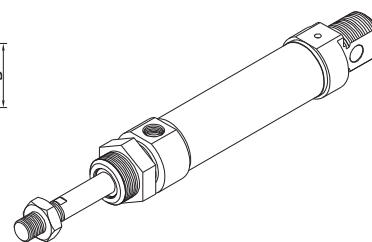
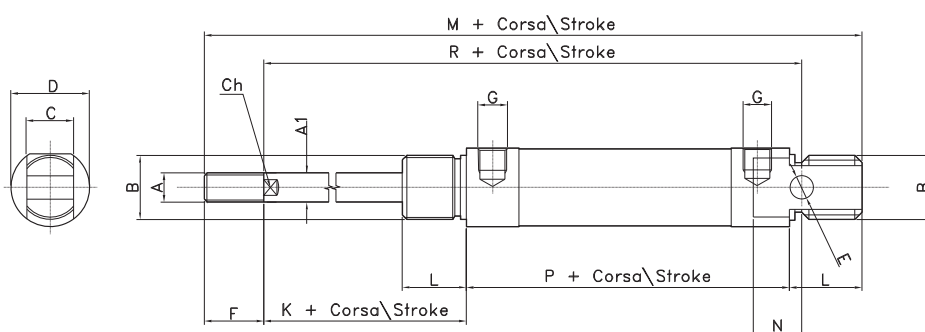
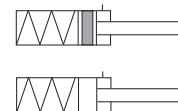

Ø	A	A1	B	C	D	E	F	G	K	L	M	N	P	R	CH
8	M4	4	M12x1.25	8	16	4	12	M5	16	12	106	6	66	84	/
10	M4	4	M12x1.25	8	16	4	12	M5	16	12	113	6	73	91	/
12	M6	6	M16x1.5	12	19	6	16	M5	22	18	128	9	72	99	5
16	M6	6	M16x1.5	12	19	6	16	M5	22	18	134.5	9	78.5	107.5	5
20	M8	8	M22x1.5	16	27	8	20	1/8 G	24	20	154	12	90	118	7
25	M10x1.25	10	M22x1.5	16	30	8	22	1/8 G	28	22	166	12	94	130	9

DOPPIO EFFETTO ALIMENTAZIONE IN ASSE PARTE POSTERIORE
DOUBLE ACTING SUPPLIER IN AXE REAR CAP

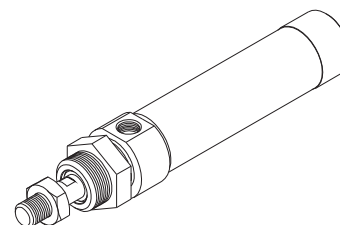
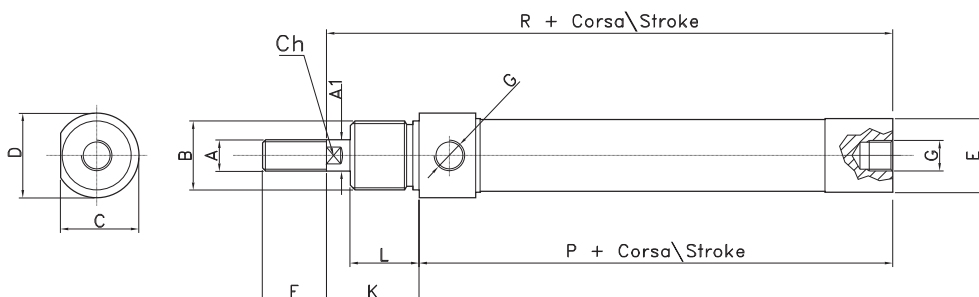
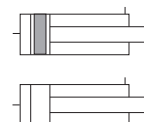

Ø	A	A1	B	C	D	E	F	G	K	L	P	R	CH
16	M6	6	M16x1.5	18	19	17.2	16	M5	22	18	52	74	5
20	M8	8	M22x1.5	25.5	27	22.2	20	1/8 G	24	20	65	89	7
25	M10x1.25	10	M22x1.5	28.5	30	27	22	1/8 G	28	22	66	94	9

SEMPLICE EFFETTO ALIMENTAZIONE IN ASSE PARTE POSTERIORE
SINGLE ACTING SUPPLIER IN AXE REAR CAP

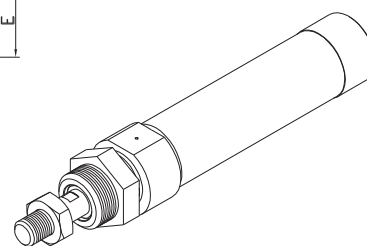
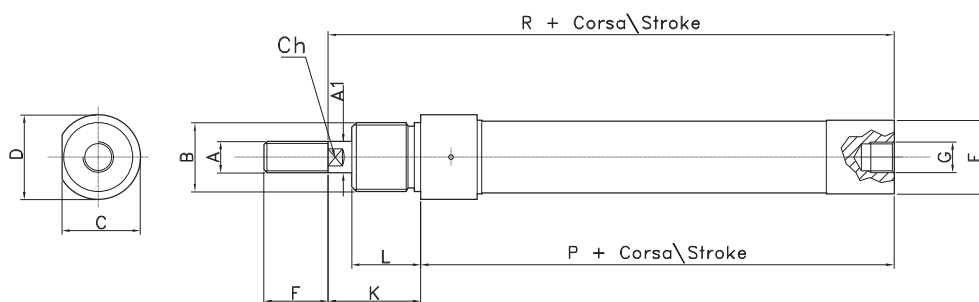
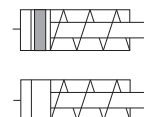

Ø	A	A1	B	C	D	F	G	K	L	P	R	CH
16	M6	6	M16x1.5	18	19	16	M5	22	18	52	74	5
20	M8	8	M22x1.5	25.5	27	20	1/8 G	24	20	65	89	7
25	M10x1.25	10	M22x1.5	28.5	30	22	1/8 G	28	22	66	94	9

ANTIROTAZIONE STELO ESAGONALE
NOT ROTATION ROD

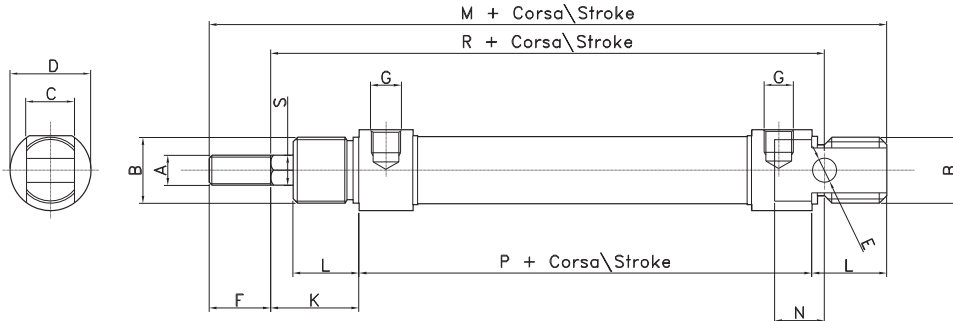
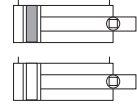

Ø	A	B	C	D	E	F	G	K	L	M	N	P	R	S
16	M6	M16x1.5	12	19	6	16	M5	22	18	109	9	53	82	6
20	M8	M22x1.5	16	27	8	20	1/8 G	24	20	131	12	67	95	8
25	M10x1.25	M22x1.5	16	30	8	22	1/8 G	28	22	140	12	68	104	10

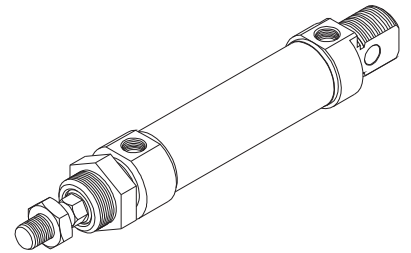

DOPPIO EFFETTO CON BLOCCASTELO
DOUBLE ACTING WITH ROD LOCK

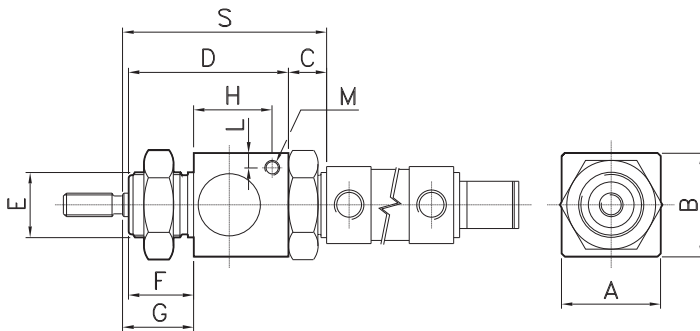
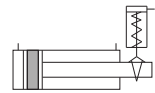

Ø	A	B	C	D	E	F	G	H	L	M	S	T	Peso in Kg. weight in Kg.
20	34	35	13	54	M22x1.5	22	26	27	5	M5	71	47	0.190
25	34	35	13	54	M22x1.5	22	28	27	5	M5	73	45	0.190

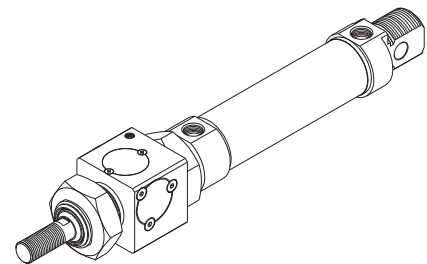

Materiale: Acciaio
Material: Steel

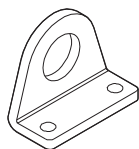
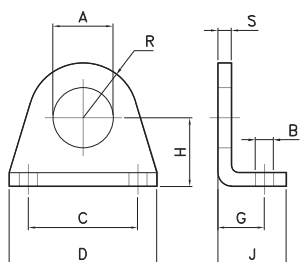

PIEDINO
PEDESTAL

CODE	Ø
AR415508	8-10
AR415512	12-16
AR415520	20-25

Ø	A	B	C	D	G	H	J	R	S	Peso (g)
8-10	12	4.5	25	35	11	16	16	10	3	20
12-16	16	5.5	32	42	14	20	20	12.5	4	40
20-25	22	6.6	40	54	17	25	25	20	5	90

Materiale: Acciaio
Material: Steel

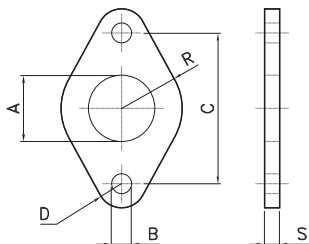

FLANGIA
FLANGE

CODE	Ø
AR415708	8-10
AR415712	12-16
AR415720	20-25

Ø	A	B	C	D	R	S	Peso (g)
8-10	12	4.5	30	5	11	3	12
12-16	16	5.5	40	6	15	4	26
20-25	22	6.6	50	8	20	5	50

Materiale: Acciaio
Material: Steel

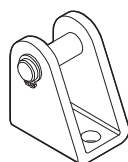
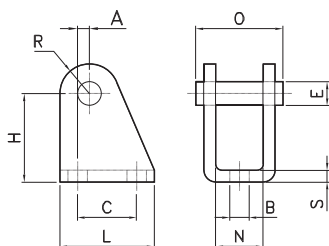

CERNIERA FEMMINA
FEMALE HINGE

CODE	Ø
AR415408	8-10
AR415412	12-16
AR415420	20-25

Ø	B	E	C	H	L	N	O	R	S	Peso (g)
8-10	4.5	4	12.5	24	20	8.1	17	5	2.5	20
12-16	5.5	6	15	27	25	12.1	23	7	3	36
20-25	6.6	8	20	30	32	16.1	29.5	10	4	78

Materiale: Acciaio
Material: Steel

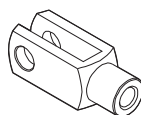
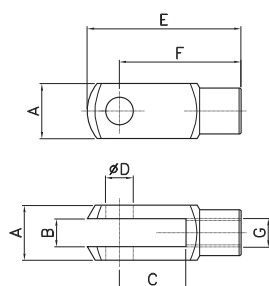

FORCELLA
YOKE

CODE	Ø
AR40670	8-10
AR40671	12-16
AR40672	20
AR40673	25

Ø	A	B	C	D	E	F	G	Peso (g)
8-10	8	4	8	4	21	16	M4	5
12-16	12	6	12	6	31	24	M6	14
20	16	8	16	8	42	32	M8	35
25	20	10	20	10	52	40	M10x1.25	72

Materiale: Acciaio
Material: Steel

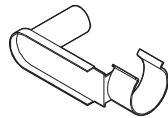
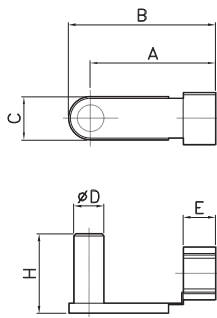

CLIPS PER FORCELLA
CLIPS FOR YOKE

CODE	Ø
AR40680	8-10
AR40681	12-16
AR40682	20
AR40683	25

Ø	A	B	C	D	E	H	Peso (g)
8-10	15.5	19	7	4	4.5	11	2
12-16	22.5	28	10	6	6.5	16	5
20	30.5	37	12.5	8	8	22	11
25	38	46	14.5	10	10	26	19

Materiale: Acciaio
Material: Steel

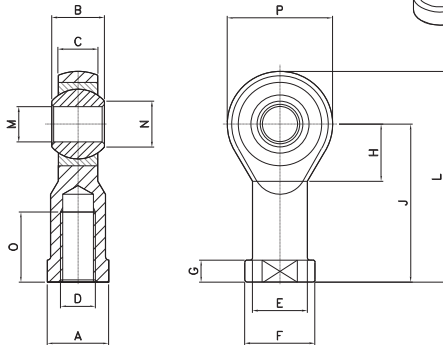

TESTA A SNODO
ROD ENDS

CODE	Ø
AR40655	8-10
AR40656	12-16
AR40657	20
AR40660	25

Ø	A	B	C	D	E	F	G	H	J	L	M	N	O	P
8-10	9	8	6	M4	9	11	4	10	27	36	5	7.7	10	18
12-16	11	9	6.75	M6	10	13	5	11	30	40	6	8.9	12	20
20	14	12	9	M8	12.5	16	5	13	36	48	8	10.4	16	24
25	17	14	10.5	M10x1.25	15	19	6.5	15	43	57	10	12.9	20	28

Materiale: Acciaio
Material: Steel

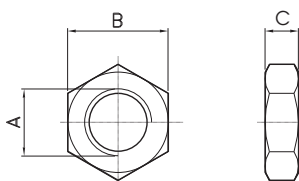

DADO PER STELO
NUT FOR ROD

CODE	Ø	A	B	C
DAN4	8-10	M4	7	3
DAN6	12-16	M6	10	5
DAN8	20	M8	13	6.5
DAN10X1,25	25	M10X1,25	17	8

Materiale: Acciaio
Material: Steel

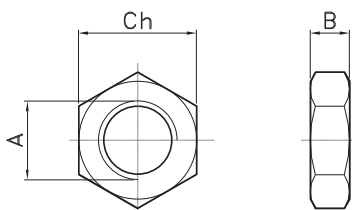

DADO PER TESTATA
NUT FOR CAP

CODE	Ø
DAD12X1,25	8-10
DAD16X1,25	12-16
DAD22X1,5	20-25

Ø	A	B	Ch	Peso (g)
8-10	M12x1.25	7	19	12
12-16	M16x1.5	8	24	20
20-25	M22x1.5	10	32	35

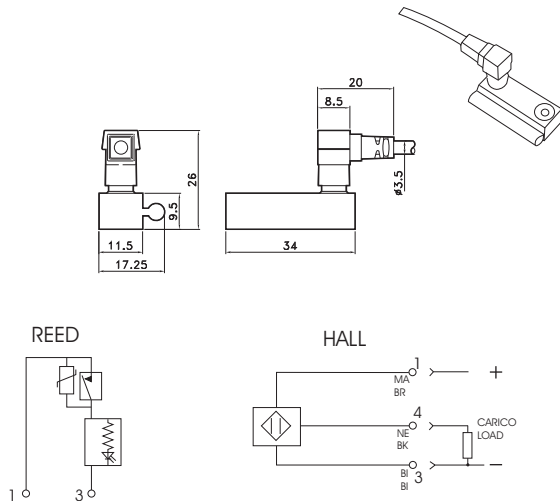

SENSORE UNIVERSALE
UNIVERSAL SWITCH

CODE	
AR4024110	REED 2 FILI CON CONN. / REED 2 WIRES WITH CONN.
AR4024120	HALL 3 FILI CON CONN. / HALL 3 WIRES WITH CONN.

DATI TECNICI / TECHNICAL DATA

Grado di protezione / Protection class	IP 67 EN 60529
Temp. di impiego / Working temp.	-20C° + 85C°
Materiale custodia / Housing material	PA
Tensione in DC / Tension in DC	Reed 3-230V / Hall 6-30V
Tensione in AC / Tension in AC	Reed 3-230V
Corrente a 25 C° / Current at 25 C°	Reed 0,20A / Hall 0,20A
Tempo inserzione / On time	Reed 0,5mS / Hall 0,8 uS
Tempo disinserzione / Off time	Reed 0,1mS / Hall 0,3 uS

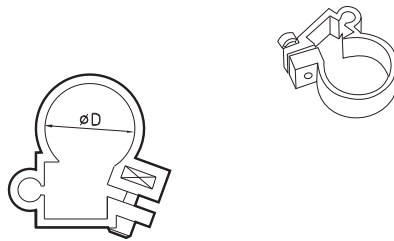

ADATTATORE SENSORE UNIVERSALE
ADAPTOR FOR UNIVERSAL SWITCH

CODE	Ø	D
AR4025008	8	12
AR4025010	10	14
AR4025012	12	16
AR4025016	16	20
AR4025020	20	24
AR4025025	25	29

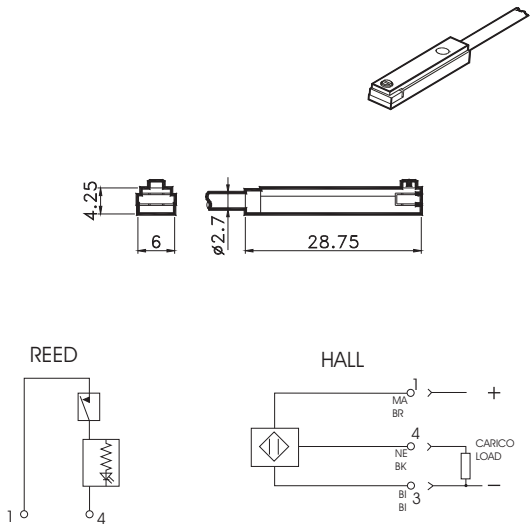

SENSORE A T
"T" SWITCH

CODE	
AR4023010	REED 2 FILI (MT.2,5) / REED WITH 2 WIRES (MT.2,5)
AR4023020	HALL 3 FILI (MT.2,5) / HALL WITH 3 WIRES (MT.2,5)
AR4023110	REED 2 FILI + M8 (CM 30) / REED WITH 2 WIRES + M8 CONN.
AR4023120	HALL 3 FILI + M8 (CM 30) / HALL WITH 3 WIRES + M8 CONN.

DATI TECNICI / TECHNICAL DATA

Grado di protezione / Protection class	IP 67 EN 60529
Temp. di impiego / Working temp.	-20C° + 85C°
Materiale custodia / Housing material	PA
Tensione in DC / Tension in DC	Reed 3-30V / Hall 6-30V
Tensione in AC / Tension in AC	Reed 3-30V
Corrente a 25 C° / Current at 25 C°	Reed 0,20A / Hall 0,20A
Tempo inserzione / On time	Reed 0,5mS / Hall 0,8 uS
Tempo disinserzione / Off time	Reed 0,1mS / Hall 0,3 uS



ADATTATORE SENSORE A T
ADAPTOR FOR T SWITCH

CODE	Ø
AR4199008	8
AR4199010	10
AR4199012	12
AR4199016	16
AR4199020	20
AR4199025	25



Serie di cilindri completamente in acciaio inox. Ideali per ambienti nel settore alimentare, vengono realizzati in tre diametri 16-20-25. Anche in questa versione le testate sono fissate alla camicia mediante rullatura.

The cylinders of the MX series are made of stainless steel. They are ideal for the food industry and are available with three different bores: 16-20-25. The cape heads are fixed to the tube through a process of rolling. They are available in different versions, single /double effect, magnetic, cushioned. A complete range of fixing accessories is available, and the production of customized cylinders on drawing is also possible.

CHIAVE DI CODIFICA / KEY TO TYPE NUMBER

MX|00|1|000|0000|

→ CORSA / STROKE

→ Ø CILINDRO / Ø CYLINDER

→ VERSIONE / VERSION

01 = DOPPIO EFFETTO-MAGNETICO / DOUBLE ACTING - MAGNETIC

03 = STELO PASSANTE - MAGNETICO / THROUGHROD - MAGNETIC

05 = DOPPIO EFFETTO-MAGNETICO-AMMORTIZZATO / DOUBLE ACTING-MAGNETIC-CUSHONING

07 = STELO PASSANTE-MAGNETICO-AMMORTIZZATO / THROUGH ROD-MAGNETIC-CUSHONING

VERSIONE - VERSION

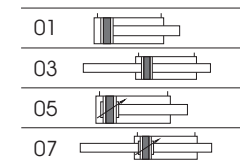

CORSE STANDARD - STANDARD STROKES

Ø16	mm10-25-50-80-100-125-160-200-250-320-400-500
Ø20	mm10-25-50-80-100-125-160-200-250-320-400-500
Ø25	mm10-25-50-80-100-125-160-200-250-320-400-500

Corse versione ammortizzato - strokes cushioning version

Ø20	mm10-25-50-80-100-125-160-200-250-320
Ø25	mm10-25-50-80-100-125-160-200-250-320-400-500

DATI TECNICI / TECHNICAL DATA

Fluido - Fluid	Aria con o senza lubrificazione - Lubricated or non lubricated air
Temperatura di esercizio - Operating temperature range	-20C° / +80C°
Pressione massima di esercizio - Max operating pressure	10 bar
Forze sviluppate - Force	pag.datì tecnici / technical informations page
Consumo aria - Air consumption	pag.datì tecnici / technical informations page

COMPONENTI / COMPONENTS

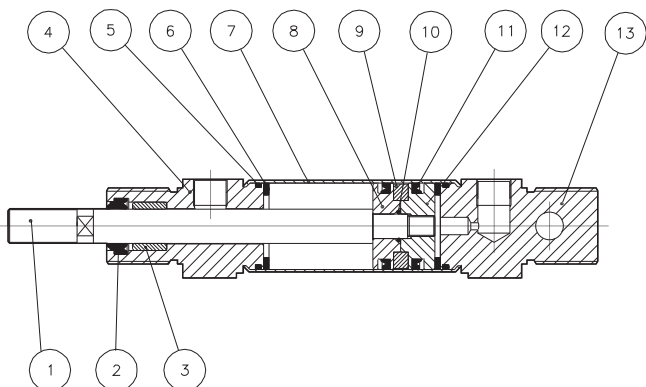

pos.	descrizione / description	materiale / material
1	stelo / rod	acciaio inox 316 / stainless steel AISI 316
2	guarnizione stelo / rod seal	poliuretano / polyurethane
3	bussola guida / guide bush	bronzo / bronze
4	testata anteriore / front cap	acciaio inox 304 / stainless steel AISI 304
5	o-ring	NBR
6	paracolpo / bumper	neoprene
7	tubo / tube	acciaio inox 304 / stainless steel AISI 304
8	pistone / piston	ot 58
9	magnete / magnet	plastoferrite
10	o-ring	NBR
11	guarnizione pist. / seal piston	poliuretano / polyurethane
12	pistone / piston	ot 58
13	testata posteriore / rear cap	acciaio inox 304 / stainless steel AISI 304

DOPPIO EFFETTO
DOUBLE ACTING 

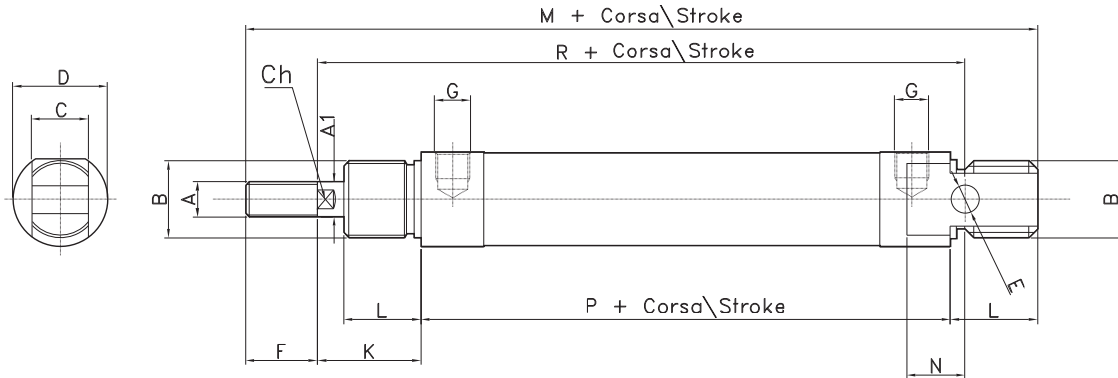

Ø	A	A1	B	C	D	E	F	G	K	L	M	N	P	R	CH
16	M6	6	M16x1.5	12	19	6	16	M5	22	18	109	9	53	82	5
20	M8	8	M22x1.5	16	27	8	20	1/8 G	24	20	131	12	67	95	7
25	M10x1.25	10	M22x1.5	16	30	8	22	1/8 G	28	22	140	12	68	104	9

STELO PASSANTE
THROUGH ROD 

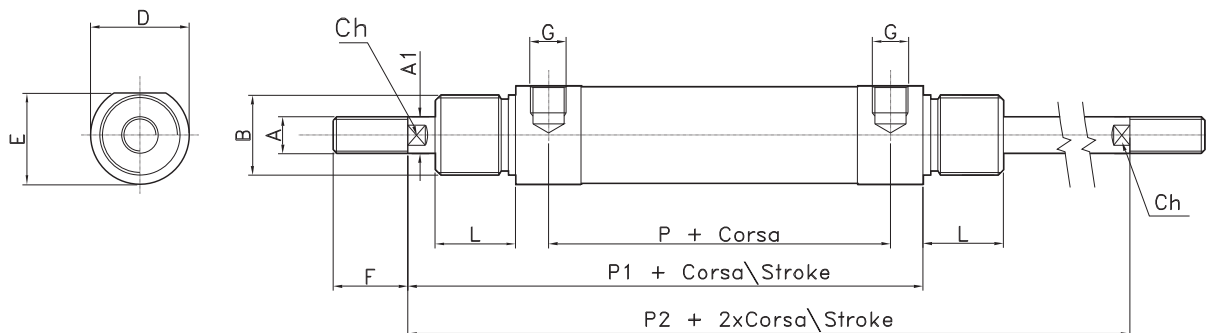

Ø	A	A1	B	D	E	F	G	L	P	P1	P2	Ch
16	M6	6	M16x1.5	19	18	16	M5	18	43	75.5	97.5	5
20	M8	8	M22x1.5	27	25.5	20	1/8"G	20	51.5	92	116	7
25	M10x1.25	10	M22x1.5	30	28.5	22	1/8"G	22	52	97	125	9

DOPPIO EFFETTO
DOUBLE ACTING

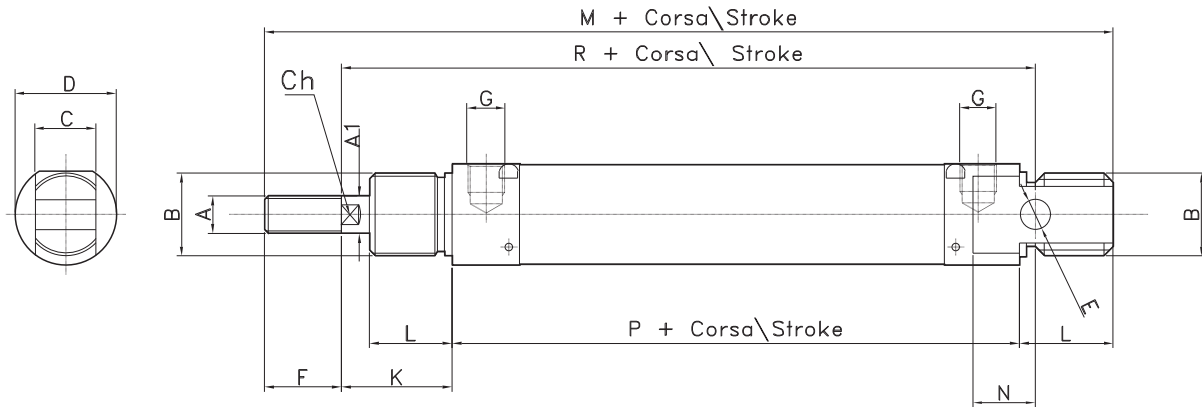
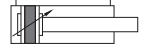

Ø	A	A1	B	C	D	E	F	G	K	L	M	N	P	R	CH
20	M8	8	M22x1.5	16	27	8	20	1/8 G	24	20	131	12	67	95	7
25	M10x1.25	10	M22x1.5	16	30	8	22	1/8 G	28	22	140	12	68	104	9

STELO PASSANTE
THROUGH ROD

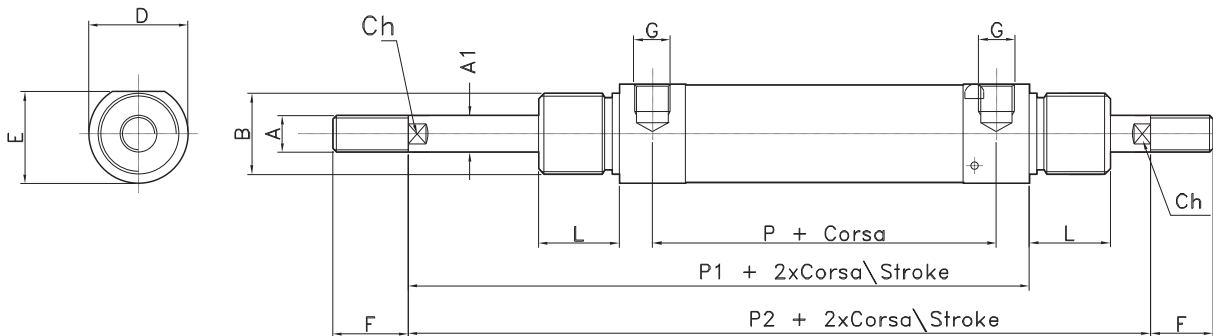

Ø	A	A1	B	D	E	F	G	L	P	P1	P2	Ch
20	M8	8	M22x1.5	27	25.5	20	1/8" G	20	51	91	115	7
25	M10x1.25	10	M22x1.5	30	28.5	22	1/8" G	22	52	96	124	9

Materiale: Inox AISI 304
Material: Stainless steel AISI 304

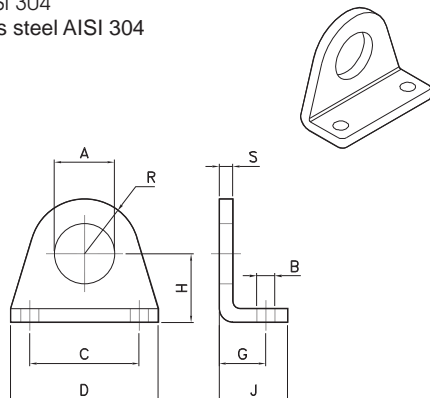

PIEDINO INOX
INOX PEDESTAL
CODE

AR416116	16
AR416120	20-25

Ø	A	B	C	D	G	H	J	R	S	Peso (g)
8-10	12	4.5	25	35	11	16	16	10	3	20
12-16	16	5.5	32	42	14	20	20	12.5	4	40
20-25	22	6.6	40	54	17	25	25	20	5	90

Materiale: Inox AISI 304
Material: Stainless steel AISI 304

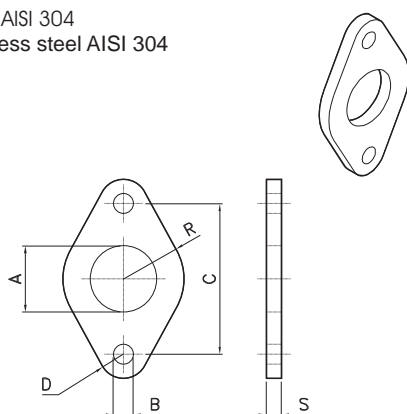

FLANGIA INOX
INOX FLANGE
CODE

	Ø
AR416216	16
AR416220	20-25

Ø	A	B	C	D	R	S	Peso (g)
8-10	12	4.5	30	5	11	3	12
12-16	16	5.5	40	6	15	4	26
20-25	22	6.6	50	8	20	5	50

Materiale: Inox AISI 304
Material: Stainless steel AISI 304

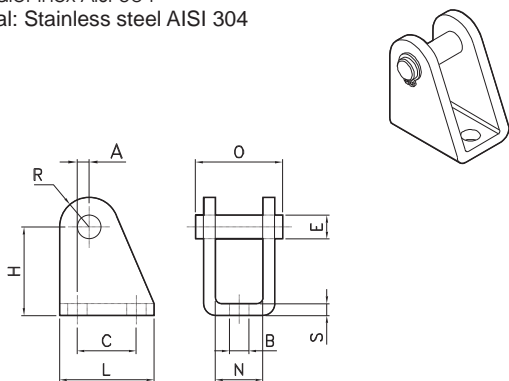

CERNIERA FEMMINA INOX
INOX FEMALE HINGE
CODE

	Ø
AR416316	16
AR416320	20-25

Ø	B	E	C	H	L	N	O	R	S	Peso (g)
8-10	4.5	4	12.5	24	20	8.1	17	5	2.5	20
12-16	5.5	6	15	27	25	12.1	23	7	3	36
20-25	6.6	8	20	30	32	16.1	29.5	10	4	78

Materiale: Inox
Material: Stainless steel

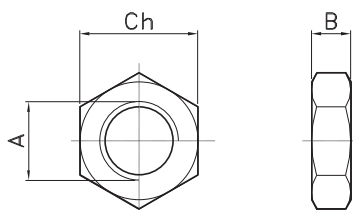

DADO PER TESTATA INOX
INOX NUT FOR CAP
CODE

	Ø
DIB16X1,25	16
DIB22X1,5	20-25

Ø	A	B	Ch
16	M16X1.5	8	24
20-25	M22X1.5	10	32

Materiale: Inox
Material: Stainless steel

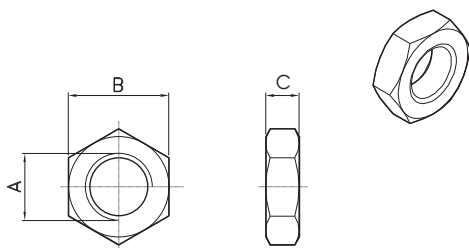

DADO PER STELO INOX
INOX NUT FOR ROD

CODE	Ø	A	B	C
DIN6	16	M6	10	5
DIN8	20	M8	13	6.5
DIN10X1,25	25	M10X1,25	17	8

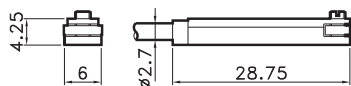
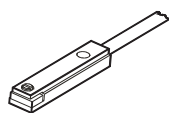

SENSORE A T
"T" SWITCH
CODE

AR4023010	REED 2 FILI (MT.2,5) / REED WITH 2 WIRES (MT.2,5)
AR4023020	HALL 3 FILI (MT.2,5) / HALL WITH 3 WIRES (MT.2,5)
AR4023110	REED 2 FILI + M8 (CM 30) / REED WITH 2 WIRES + M8 CONN.
AR4023120	HALL 3 FILI + M8 (CM 30) / HALL WITH 3 WIRES + M8 CONN.

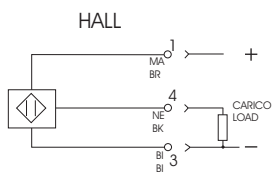
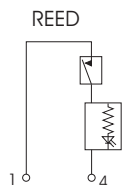

DATI TECNICI / TECHNICAL DATA

Grado di protezione / Protection class	IP 67 EN 60529
Temp. di impiego / Working temp.	-20C° +85C°
Materiale custodia / Housing material	PA
Tensione in DC / Tension in DC	Reed 3-30V / Hall 6-30V
Tensione in AC / Tension in AC	Reed 3-30V
Corrente a 25 C° / Current at 25 C°	Reed 0,20A / Hall 0,20A
Tempo inserzione / On time	Reed 0,5mS / Hall 0,8 uS
Tempo disinserzione / Off time	Reed 0,1mS / Hall 0,3 uS

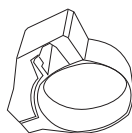

ADATTATORE SENSORE A T
ADAPTOR FOR T SWITCH

CODE	Ø
AR4199016	16
AR4199020	20
AR4199025	25



Le testate dei cilindri tondi di Air Work sono fissate alla camicia mediante rullatura.
Sono realizzabili in differenti versioni , semplice / doppio effetto, magnetici, Ammortizzati.
Sono inoltre disponibili i relativi accessori di fissaggio ed esecuzioni speciali a disegno.

The caps are fixed to the tube by process of rolling.
They are in different versions, single /double effect, Magnetic, cushioned.
Moreover are available the relative fixing accessories and special executions .

CHIAVE DI CODIFICA / KEY TO TYPE NUMBER

CT,00,1,000,0000
 ↳ CORSA / STROKE
 ↳ Ø CILINDRO / Ø CYLINDER

VERSIONE - VERSION

- 01=D.E. MAGNETICO / DOUBLE ACTING - MAGNETIC
- 02=D.E. NON MAGNETICO / DOUBLE ACTING - NON MAGNETIC
- 03=D.E. STELO PASSANTE MAGNETICO / DOUBLE ACTING THROUGH ROD MAGNETIC
- 04=D.E. STELO PASSANTE NON MAGNETICO / DOUBLE ACTING THROUGH ROD NON MAGNETIC
- 05=D.E. CON AMMORTIZZO MAGNETICO / DOUBLE ACTING WITH CUSHIONING MAGNETIC
- 06=D.E. CON AMMORTIZZO NON MAGNETICO / DOUBLE ACTING WITH CUSHIONING NON MAGNETIC
- 07=D.E. STELO PASSANTE CON AMMORTIZZO MAGNETICO / DOUBLE ACTING THROUGH ROD MAGNETIC
- 08=D.E. STELO PASSANTE CON AMMORTIZZO NON MAG. / DOUBLE ACTING THROUGH ROD NON MAGNETIC
- 09=SEMPLICE EFFETTO MOLLA ANTERIORE MAGNETICO / SINGLE ACTING FRONT SPRING MAGNETIC
- 10=SEMPLICE EFFETTO MOLLA ANTERIORE NON MAGNETICO / SINGLE ACTING FRONT SPRING NON MAGNETIC
- 11=SEMPLICE EFFETTO MOLLA POSTERIORE MAGNETICO / SINGLE ACTING REAR SPRING MAGNETIC
- 12=SEMPLICE EFFETTO MOLLA POSTERIORE NON MAGNETICO / SINGLE ACTING REAR SPRING NON MAGNETIC

VERSIONE - VERSION

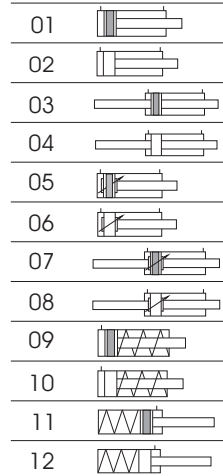

CORSE STANDARD - STANDARD STROKES

Doppio effetto - Double acting

Ø32	mm 25-50-80-100-125-160-200-250-320-400-500
Ø40	mm 25-50-80-100-125-160-200-250-320-400-500
Ø50	mm 25-50-80-100-125-160-200-250-320-400-500
Ø63	mm 25-50-80-100-125-160-200-250-320-400-500

Semplice effetto - Single acting

Ø32	mm 10-25-50
Ø40	mm 10-25-50
Ø50	mm 10-25-50
Ø63	mm 10-25-50

DATI TECNICI / TECHNICAL DATA

Fluido - Fluid	Aria con o senza lubrificazione - Lubricated or non lubricated air
Temperatura di esercizio - Operating temperature range	-20C° / +80C°
Pressione massima di esercizio - Max operating pressure	10 bar
Forze sviluppate - Force	pag.datì tecnici / technical informations page
Consumo aria - Air consumption	pag.datì tecnici / technical informations page

COMPONENTI / COMPONENTS

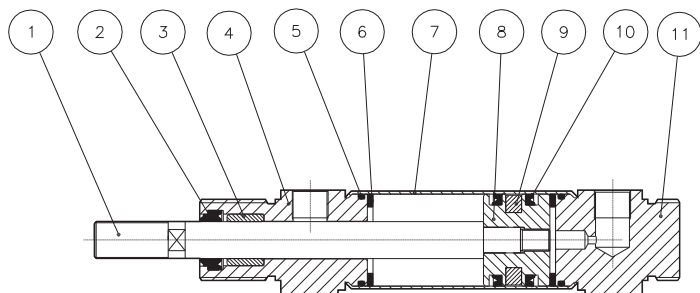

pos.	descrizione / description	materiale / material
1	stelo / rod	acciaio C40 cromato / steel C40 chrome
2	guarnizione stelo / rod seal	poliuretano / polyurethane
3	bussola guida / guide bush	bronzo / bronze
4	testata anteriore / front cap	alluminio / aluminium
5	o-ring	NBR
6	paracolpo / bumper	neoprene
7	tubo / tube	acciaio inox 304 / stainless steel aisi 304
8	pistone / piston	alluminio / aluminium
9	magnete / magnet	plastoferrite
10	guarnizione pist. / seal piston	poliuretano / polyurethane
11	testata posteriore / rear cap	alluminio / aluminium

DOPPIO EFFETTO
DOUBLE ACTING

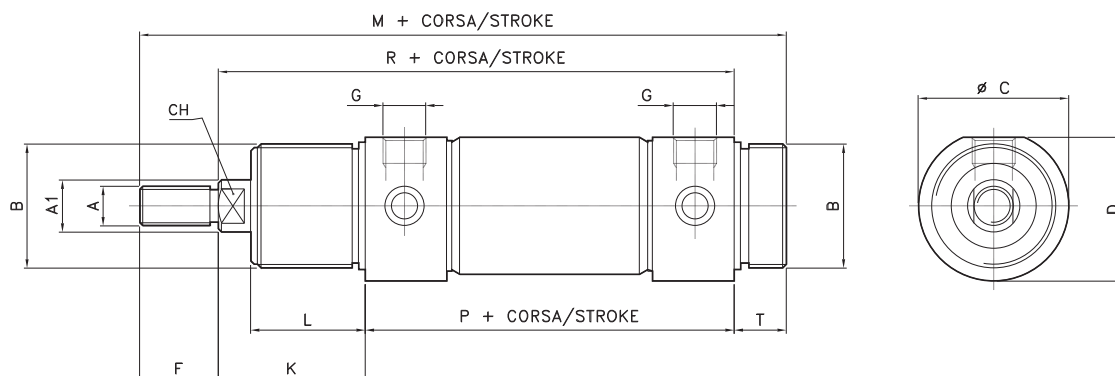
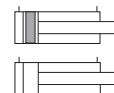

Ø	A	A1	B	C	D	F	G	K	L	M	P	R	T	CH
32	M10x1.25	12	M30x1.5	38	36.5	20	1/8" GAS	38	30	168	96	125	14	10
40	M12x1.25	16	M38x1.5	46	44	24	1/4" GAS	45	35	198	113	146	16	12
50	M16x1.5	20	M45x1.5	57	55	32	1/4" GAS	50	38	220	120	158	18	16
63	M16x1.5	20	M45x1.5	70	67.5	32	3/8" GAS	50	38	224	124	163	18	16

STELO PASSANTE
THROUGH ROD

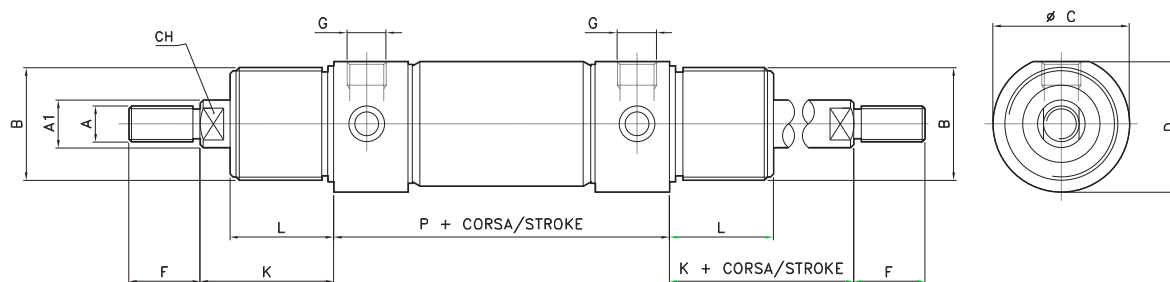
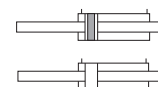

Ø	A	A1	B	C	D	F	G	K	L	P	CH
32	M10x1.25	12	M30x1.5	38	36.5	20	1/8" GAS	38	30	96	10
40	M12x1.25	16	M38x1.5	46	44	24	1/4" GAS	45	35	113	12
50	M16x1.5	20	M45x1.5	57	55	32	1/4" GAS	50	38	120	16
63	M16x1.5	20	M45x1.5	70	67.5	32	3/8" GAS	50	38	124	16

AMMORTIZZATO
CUSHIONING

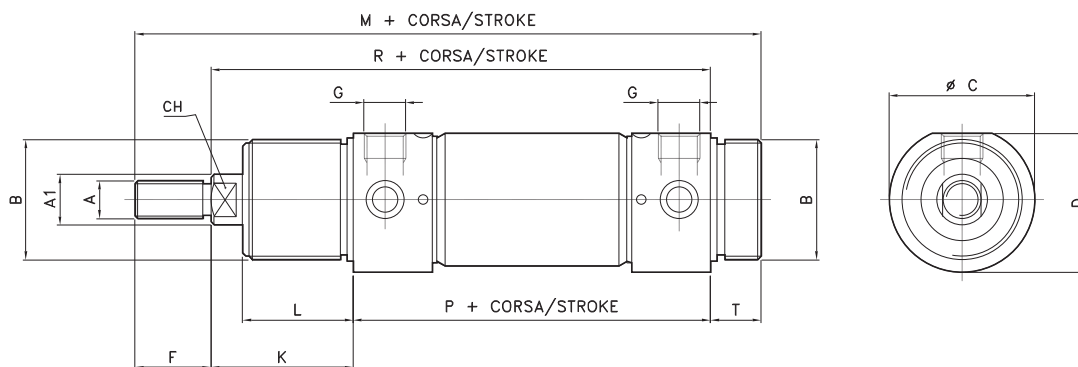
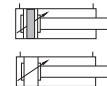

Ø	A	A1	B	C	D	F	G	K	L	M	P	R	T	CH
32	M10x1.25	12	M30x1.5	38	36.5	20	1/8" GAS	38	30	168	96	125	14	10
40	M12x1.25	16	M38x1.5	46	44	24	1/4" GAS	45	35	198	113	146	16	12
50	M16x1.5	20	M45x1.5	57	55	32	1/4" GAS	50	38	220	120	158	18	16
63	M16x1.5	20	M45x1.5	70	67.5	32	3/8" GAS	50	38	224	124	163	18	16

STELO PASSANTE
THROUGH ROD

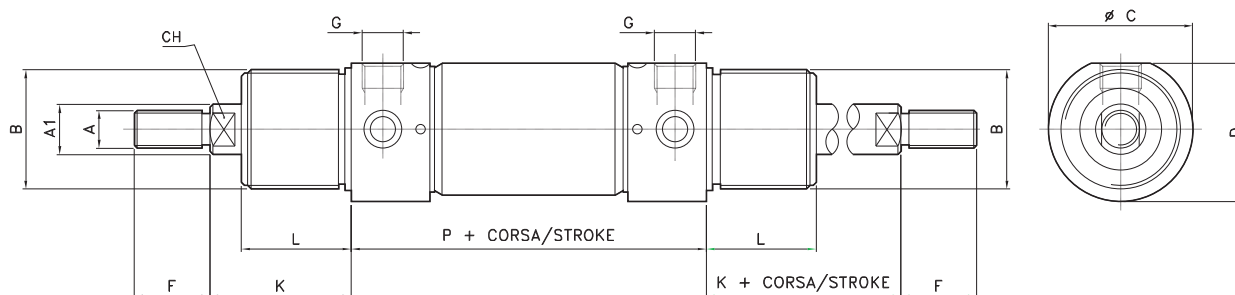
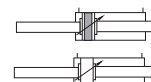

Ø	A	A1	B	C	D	F	G	K	L	P	CH
32	M10x1.25	12	M30x1.5	38	36.5	20	1/8" GAS	38	30	96	10
40	M12x1.25	16	M38x1.5	46	44	24	1/4" GAS	45	35	113	12
50	M16x1.5	20	M45x1.5	57	55	32	1/4" GAS	50	38	120	16
63	M16x1.5	20	M45x1.5	70	67.5	32	3/8" GAS	50	38	124	16

SEMPLICE EFFETTO
SINGLE ACTING

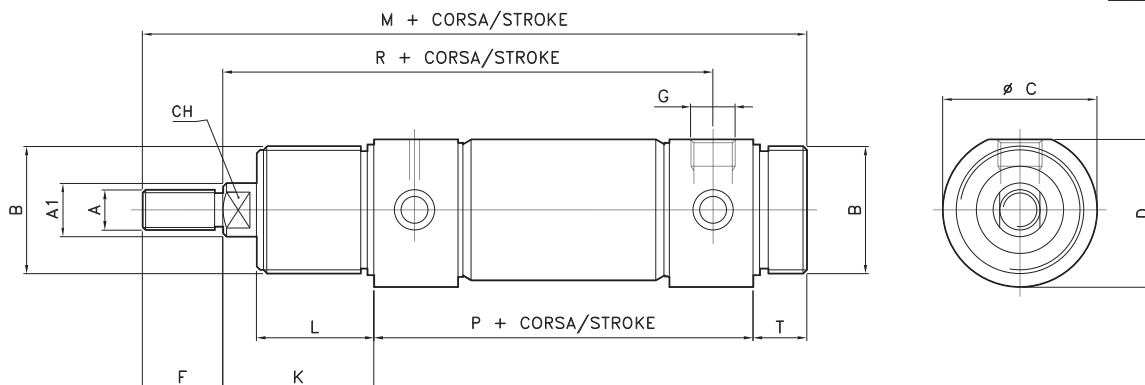
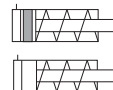

Ø	A	A1	B	C	D	F	G	K	L	M	P	R	T	CH
32	M10x1.25	12	M30x1.5	38	36.5	20	1/8" GAS	38	30	168	96	125	14	10
40	M12x1.25	16	M38x1.5	46	44	24	1/4" GAS	45	35	198	113	146	16	12
50	M16x1.5	20	M45x1.5	57	55	32	1/4" GAS	50	38	220	120	158	18	16
63	M16x1.5	20	M45x1.5	70	67.5	32	3/8" GAS	50	38	224	124	163	18	16

SEMPLICE EFFETTO
SINGLE ACTING

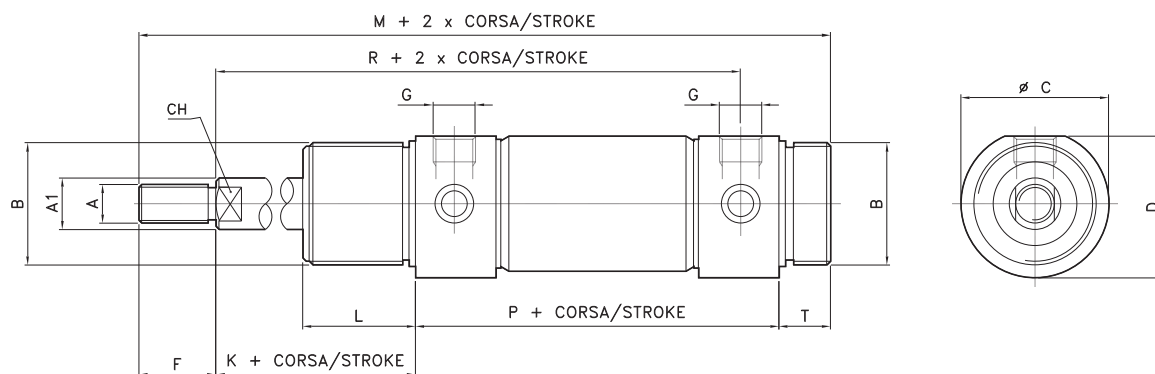
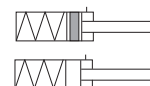

Ø	A	A1	B	C	D	F	G	K	L	M	P	R	T	CH
32	M10x1.25	12	M30x1.5	38	36.5	20	1/8" GAS	38	30	168	96	125	14	10
40	M12x1.25	16	M38x1.5	46	44	24	1/4" GAS	45	35	198	113	146	16	12
50	M16x1.5	20	M45x1.5	57	55	32	1/4" GAS	50	38	220	120	158	18	16
63	M16x1.5	20	M45x1.5	70	67.5	32	3/8" GAS	50	38	224	124	163	18	16

Materiale: Acciaio
Material: Steel

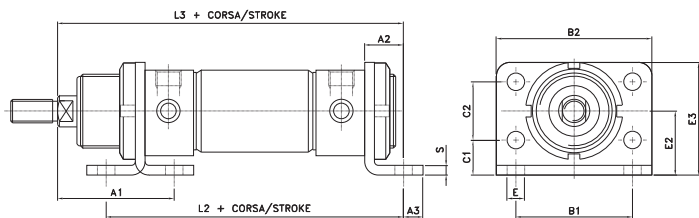
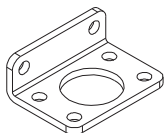

PIEDINO
PEDESTAL
CODE

CODE	Ø
AR4202032	32
AR4202040	40
AR4202050	50
AR4202063	63

Ø	A1	A2	A3	B1	B2	C1	C2	E	E2	E3	L2	L3	S
32	48	14	7	52	66	14	28	7	28	49	124	148	4
40	60	20	10	60	80	18	30	9	33	58	153	178	5
50	64	20	10	70	90	20	40	9	40	70	160	190	6
63	65	20	10	76	96	20	50	9	45	80	164	195	6

Materiale: Acciaio
Material: Steel

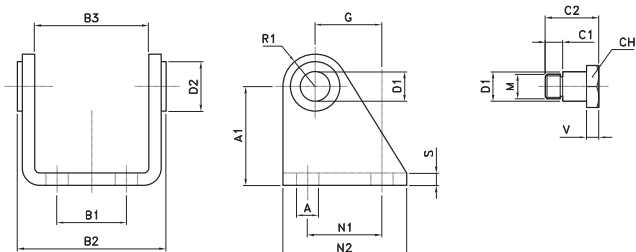
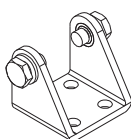

CERNIERA FEMMINA
FEMALE HINGE
CODE

CODE	Ø
AR4203032	32
AR4203040	40
AR4203050	50
AR4203063	63

Ø	D1	D2	A	A1	B1	B2	B3	G	N1	N2	R1	S	C1	C2	CH	V	M
32	10	15	7	35	20	50.1	38.1	20	24	40	12	4	6	18	13	4	M8x1
40	12	20	9	40	28	60.1	46.1	27	30	50	13	5	7	21.6	17	5	M10x1
50	14	23	9	45	36	74.1	57.1	30	34	54	14	6	9	26.4	19	6	M12x1.5
63	16	23	9	50	42	88.1	70.1	34	35	65	16	6	15	34	19	6	M14x1.5

Materiale: Acciaio
Material: Steel

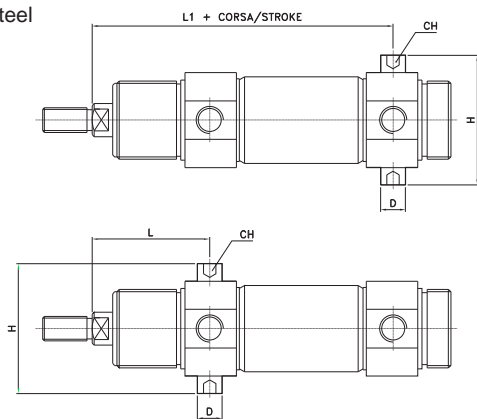

PERNI PER CERNIERA
PIVOT FOR HINGE
CODE

CODE	Ø
AR4204032	32
AR4204040	40
AR4204050	50
AR4204063	63

Ø	D	CH	H	L	L1
32	10	5	51	47	125
40	12	6	61	57	146
50	14	6	75	62	158
63	16	8	90	64	161

Materiale: Acciaio
Material: Steel

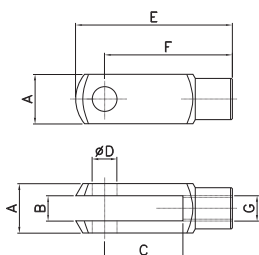
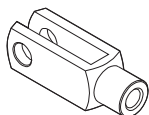

FORCELLA
YOKE
CODE

CODE	Ø
AR40673	32
AR40674	40
AR40675	50-63

Ø	A	B	C	D	E	F	G	Peso (g)
32	20	10	20	10	52	40	M10x1.25	72
40	24	12	24	12	62	48	M12x1.25	115
50-63	32	16	32	16	83	64	M16x1.5	270

Materiale: Acciaio
Material: Steel

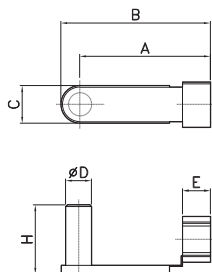
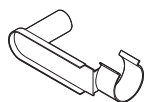

CLIPS PER FORCELLA
CLIPS FOR YOKE

CODE	Ø
AR40683	32
AR40684	40
AR40685	50-63

Ø	A	B	C	D	E	H	Peso (g)
32	37	47	15	10	10	26	19
40	45	54	16	12	12	32	30
50-63	60	73	24	16	14	40	70

Materiale: Acciaio
Material: Steel

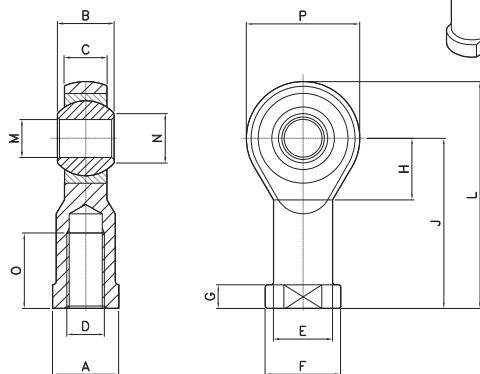

TESTA A SNODO
ROD ENDS

CODE	Ø
AR40660	32
AR40662	40
AR40665	50-63

Ø	A	B	C	D	E	F	G	H	J	L	M	N	O	P
32	17	14	10.5	M10x1.25	15	19	6.5	15	43	57	10	12.9	20	28
40	19	16	12	M12x1.25	17.5	22	6.5	17	50	66	12	15.4	22	32
50-63	22	21	15	M16x1.5	22	27	8	23	64	85	16	19.3	28	42

Materiale: Acciaio
Material: Steel

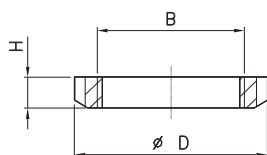
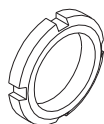

GHIERA
NUT

CODE	Ø
AR4205032	32
AR4205040	40
AR4205050	50-63

Ø	B	D	H
32	M30x1.5	45	7
40	M38x1.5	50	8
50	M45x1.5	58	9
63	M45x1.5	58	9

Materiale: Acciaio
Material: Steel

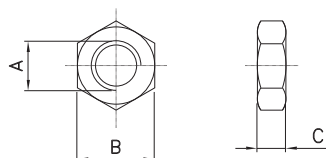

DADO PER STELO
NUT FOR ROD

CODE	Ø	A	B	C
DAD10X1.25	32	M10X1.25	17	8
DAD12X1.25	40	M12X1.25	19	6
DAD16X1.25	50-63	M16X1.5	22	6

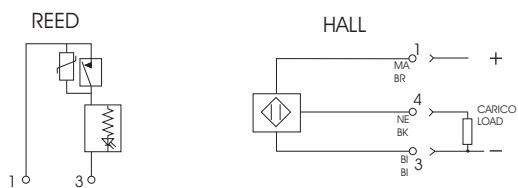
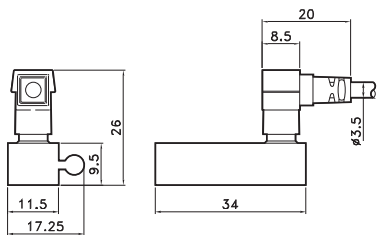
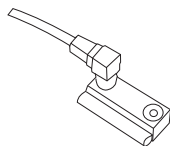

SENSORE UNIVERSALE
UNIVERSAL SWITCH
CODE

AR4024110	REED 2 FILI + M8 / REED 2 WIRES WITH M8
AR4024120	HALL 3 FILI CON + M8 / HALL 3 WIRES WITH M8

DATI TECNICI / TECHNICAL DATA

Grado di protezione / Protection class	IP 67 EN 60529
Temp. di impiego / Working temp.	-20C° +85C°
Materiale custodia / Housing material	PA
Tensione in DC / Tension in DC	Reed 3-230V / Hall 6-30V
Tensione in AC / Tension in AC	Reed 3-230V
Corrente a 25 C° / Current at 25 C°	Reed 0,20A / Hall 0,20A
Tempo inserzione / On time	Reed 0,5mS / Hall 0,8 uS
Tempo disinserzione / Off time	Reed 0,1mS / Hall 0,3 uS

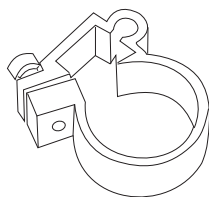

ADATTATORE SENSORE UNIVERSALE
ADAPTOR FOR UNIVERSAL SWITCH

CODE	Ø
AR4025032	32
AR4025040	40
AR4025050	50
AR4025063	63



I cilindri serie CY di Airwork sono realizzati rispettando la normativa ISO 15552 ed hanno alesaggi compresi tra 32 e 125 mm. Doppio effetto, ammortizzati e magnetici sono indicati dove è richiesta precisione ed affidabilità. Il nuovo profilo della camicia rende il prodotto interessante anche dal punto di vista estetico. Possibili realizzazioni speciali a disegno e guarnizioni in Viton per alte temperature.

The cylinders of the CY series are produced complying with the ISO 15552 norm; they have bores comprised between 32 and 125 mm. Particularly indicated where precision is important, they are available in different versions: double effect, cushioned and magnetic. The new tube profile renders the cylinder excellent also from the aesthetic side. The production of special cylinders on customer's drawing is possible, as well as the realization of versions with VISON seals.

CHIAVE DI CODIFICA / KEY TO TYPE NUMBER

CY 00 1 000 0000

→ CORSA / STROKE

→ Ø CILINDRO / Ø CYLINDER

→ GUARNIZIONI / SEALS

1=POLIURETANO / POLYURETHANE

4=GUARNIZIONE STELO PER USO PESANTE / SEAL ROD FOR HARD USE

3=VITON / VITON

6=VITON SOLO STELO / VITON ONLY ROD

→ VERSIONE - VERSION

01=DOPPIO EFFETTO / DOUBLE ACTING

03=STELO PASSANTE / THROUGH ROD

05=CON EXTRASTELO PER BS / FOR ROD LOCK BS SERIES

29=CON EXTRASTELO PER BA / FOR ROD LOCK BA SERIES

07=CON STELO INOX / WITH INOX ROD

21=TANDEM DOPPIA SPINTA / TANDEM DOUBLE PUSH

23=TANDEM DOPPIA CORSA / TANDEM DOUBLE STROKE

25=TANDEM CONTRAPPOSTI / TANDEM CONTRASTED

31=CON SOFFIETTO / WITH RUBBER BELLOW

33=CON BLOCCASTELO SERIE BS MONTATO / WITH ROD LOCK BS SERIES ASSEMBLED

35=CON BLOCCASTELO SERIE BA MONTATO / WITH ROD LOCK BA SERIES ASSEMBLED

VERSIONE - VERSION

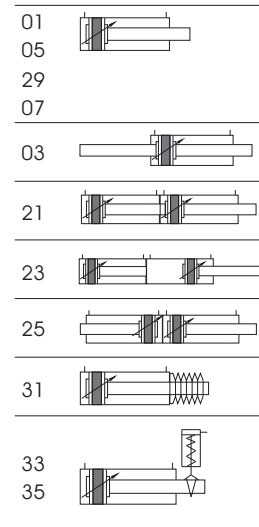

DATI TECNICI / TECHNICAL DATA

Alesaggi - Sizes	Ø32-40-50-63-80-100-125
Corse standard - Standard strokes	mm 25-50-80-100-125-160-200-250-320-350-400-500-600-700-800-900-1000
Fluido - Fluid	Aria con o senza lubrificazione - Lubricated or non lubricated air
Temperatura di esercizio - Operating temperature range	Poliuretano : -20C°+80C° / Viton: -10C°+150C°
Pressione massima di esercizio - Max operating pressure	10 bar
Forze sviluppate - Force	pag.datì tecnici / technical informations page
Consumo aria - Air consumption	pag.datì tecnici / technical informations page

PROFILO TUBO / TUBE PROFILE

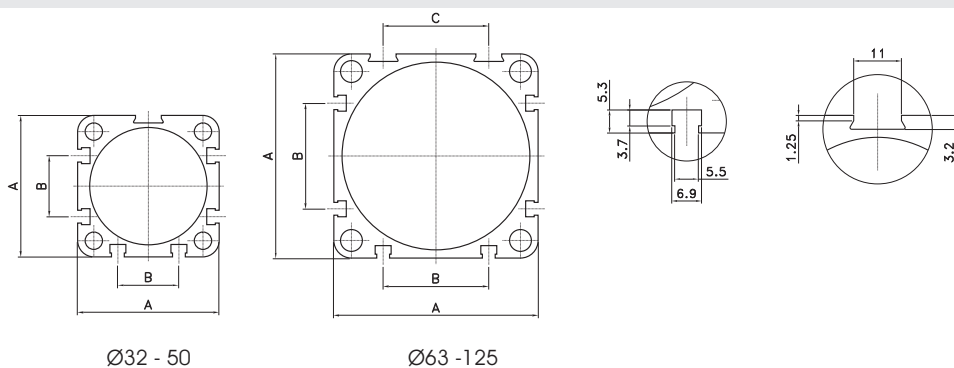

Ø	QUOTE		
	A	B	C
32	44.5	17	--
40	50.5	23	--
50	60.3	26	--
63	70	37	35
80	87	45	45
100	106	50	46
125	132	56	50

CILINDRI ISO 15552- SERIE CZ CYLINDERS ISO 15552- CZ SERIES



I cilindri serie CZ di Airwork sono realizzati rispettando la normativa ISO 15552 ed hanno alesaggi compresi fra 32 e 125 mm.
Doppio effetto, ammortizzati e magnetici sono indicati dove è richiesta precisione ed affidabilità.
Il nuovo profilo della camicia rende il prodotto interessante anche dal punto di vista estetico.
Possibili realizzazioni speciali a disegno e guarnizioni in Viton per alte temperature.

The cylinders of the CZ series are produced complying with the ISO 15552 norm; they have bores comprised between 32 and 125 mm. Particularly indicated where precision is important, they are available in different versions: double effect, cushioned and magnetic.
The production of special cylinders on customer's drawing is possible, as well as the realization of versions with VISON seals.

CHIAVE DI CODIFICA / KEY TO TYPE NUMBER

CZ,00,1,000,0000

→ CORSA / STROKE

→ Ø CILINDRO / Ø CYLINDER

→ GUARNIZIONI / SEALS

1=POLIURETANO / POLYURETHANE

4=GUARNIZIONE STELO PER USO PESANTE / SEAL ROD FOR HARD USE

3=VITON / VITON

6=VITON SOLO STELO / VITON ONLY ROD

→ VERSIONE - VERSION

01=DOPPIO EFFETTO / DOUBLE ACTING

03=STELO PASSANTE / THROUGH ROD

05=CON EXTRASTELO PER BS / FOR ROD LOCK BS SERIES

29=CON EXTRASTELO PER BA / FOR ROD LOCK BA SERIES

07=CON STELO INOX / WITH INOX ROD

21=TANDEM DOPPIA SPINTA / TANDEM DOUBLE PUSH

23=TANDEM DOPPIA CORSA / TANDEM DOUBLE STROKE

25=TANDEM CONTRAPPOSTI / TANDEM CONTRASTED

31=CON SOFFIETTO / WITH RUBBER BELLOW

33=CON BLOCCASTELO SERIE BS MONTATO / WITH ROD LOCK BS SERIES ASSEMBLED

35=CON BLOCCASTELO SERIE BA MONTATO / WITH ROD LOCK BA SERIES ASSEMBLED

VERSIONE - VERSION

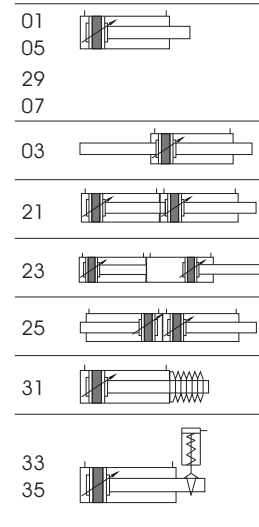

DATI TECNICI / TECHNICAL DATA

Alesaggi - Sizes	Ø32-40-50-63-80-100-125
Corse standard - Standard strokes	mm 25-50-80-100-125-160-200-250-320-350-400-500-600-700-800-900-1000
Fluido - Fluid	Aria con o senza lubrificazione - Lubricated or non lubricated air
Temperatura di esercizio - Operating temperature range	Poliuretano : -20C°+80C° / Viton: -10C°+150C°
Pressione massima di esercizio - Max operating pressure	10 bar
Forze sviluppate - Force	pag.datì tecnici / technical informations page
Consumo aria - Air consumption	pag.datì tecnici / technical informations page

PROFILO TUBO / TUBE PROFILE

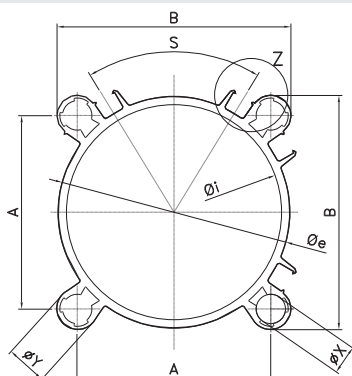

Øi	Øe	QUOTE				
		A	B	ØX	ØY	S
32 ^{H11}	36	32.5	42.5	5.4	10	46°
40 ^{H11}	44.2	38	48	5.4	10	51°
50 ^{H11}	54.4	46.5	59.5	7.4	13	54°
63 ^{H11}	67.7	56.5	69.5	7.4	13	61°
80 ^{H11}	85.5	72	86	9.1	14	65°
100 ^{H12}	105.5	89	105.5	9.1	16.5	68°
125 ^{H12}	131	110	131	10.6	17	70°

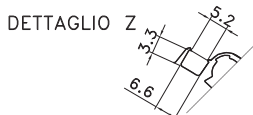

COMPONENTI / COMPONENTS

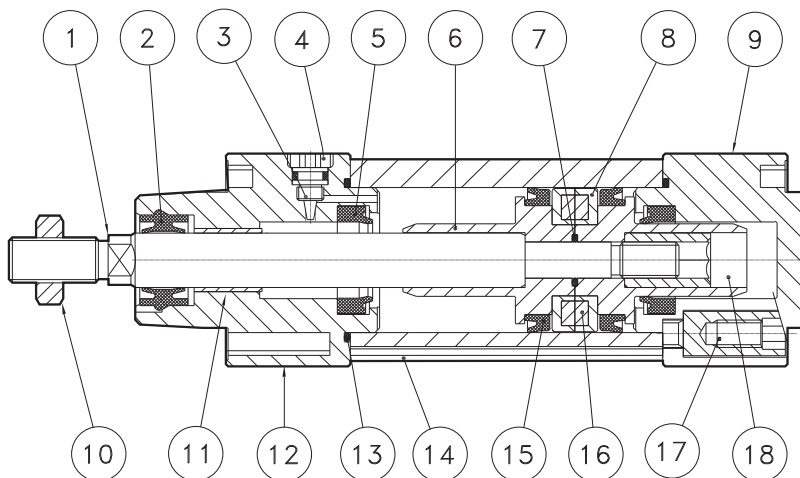

pos.	descrizione / description	materiale / material
1	stelo / rod	acciaio C40 cromato / steel C40 chromed
2	guarnizione stelo / rod seal	poliuretano / polyurethane
3	vite reg. ammortizzo / regulator cushion screw	ottone nichelato / nickel brass
4	grano ferma vite / stop cushion srew	ottone nichelato / nickel brass
5	guarnizione ammortizzo / cushion seal	poliuretano / polyurethane
6	semipistone / half piston	POM
7	o-ring	NBR
8	guida pistone / guide piston	POM
9	testata posteriore / rear cap	alluminio / aluminium
10	dado / nut	acciaio zincato / steel zinc plate
11	bussola guida / guide bush	PTFE 32-63 bronze 80-125
12	testata anteriore / front cap	alluminio / aluminium
13	o-ring	NBR
14	tubo / tube	alluminio / aluminium
15	guarnizione pistone / piston seal	poliuretano / polyurethane
16	magnete / magnet	plastoferrite
17	vite serraggio testata / fixing cap screw	acciaio zincato / steel zinc plate
18	dado fissaggio pistone / fixing piston nut	acciaio zincato / steel zinc plate

SEZIONE / SECTION

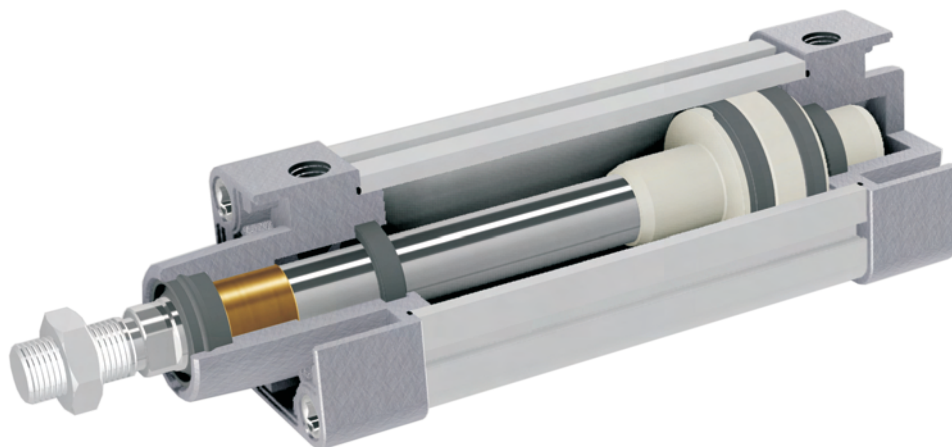

DOPPIO EFFETTO
DOUBLE ACTING

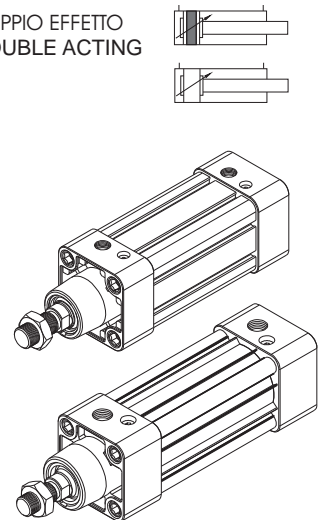
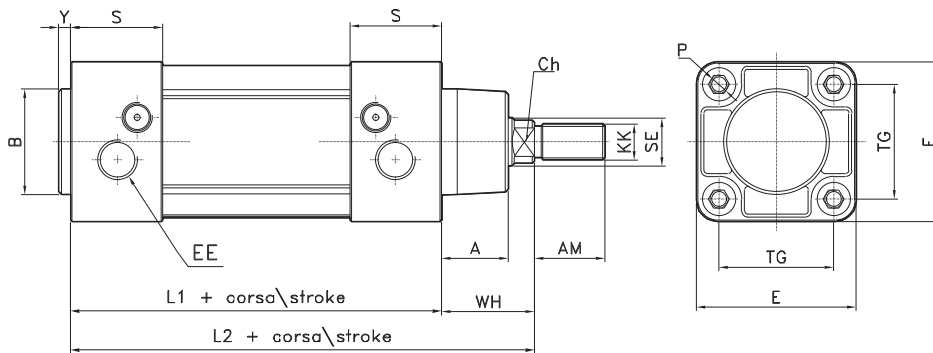

Ø	A	AM (-2)	B ø11	E	EE	Y (-1)	KK	L1	L2	P	S	SE ø	TG	WH	Ch
32	20	22	30	47	G1/8"	4	M10x1.25	94 ± 0.4	120	M6	28	12	32.5	26	10
40	22	24	35	53	G1/4"	4	M12x1.25	105 ± 0.7	135	M6	30.5	16	38	30	13
50	28	32	40	65	G1/4"	4	M16x1.5	106 ± 0.7	143	M8	31	20	46.5	37	16
63	28	32	45	75	G3/8"	4	M16x1.5	121 ± 0.8	158	M8	35	20	56.5	37	16
80	34	40	45	95	G3/8"	4	M20x1.5	128 ± 0.8	174	M10	36	25	72	46	21
100	38	40	55	115	G1/2"	4	M20x1.5	138 ± 1	189	M10	41	25	89	51	21
125	50	54	60	140	G1/2"	5	M27x2	160 ± 1	225	M12	45	32	110	65	27

STELO PASSANTE
THROUGH ROD

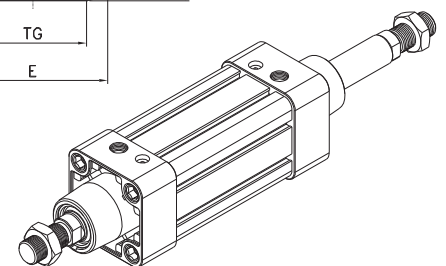
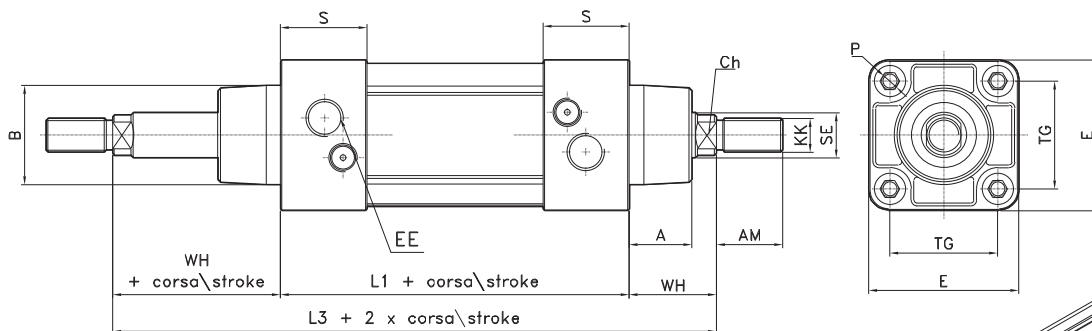

Ø	A	AM (-2)	B ø11	E	EE	KK	L1	L2	L3	P	S	SE ø	TG	WH	Ch
32	20	22	30	47	G1/8"	M10x1.25	94 ± 0.4	120	146 ± 0.4	M6	28	12	32.5	26	10
40	22	24	35	53	G1/4"	M12x1.25	105 ± 0.7	136	165 ± 0.7	M6	30.5	16	38	30	13
50	28	32	40	65	G1/4"	M16x1.5	106 ± 0.7	143	180 ± 0.7	M8	31	20	46.5	37	16
63	28	32	45	75	G3/8"	M16x1.5	121 ± 0.8	158	195 ± 0.8	M8	35	20	56.5	37	16
80	34	40	45	95	G3/8"	M20x1.5	128 ± 0.8	174	220 ± 0.8	M10	36	25	72	46	21
100	38	40	55	115	G1/2"	M20x1.5	138 ± 1	189	240 ± 1	M10	41	25	89	51	21
125	50	54	60	140	G1/2"	M27x2	160 ± 1	225	290 ± 1	M12	45	32	110	65	27

TANDEM DOPPIA SPINTA
TANDEM DOUBLE PUSH



TANDEM DOPPIA CORSA
TANDEM DOUBLE STROKE

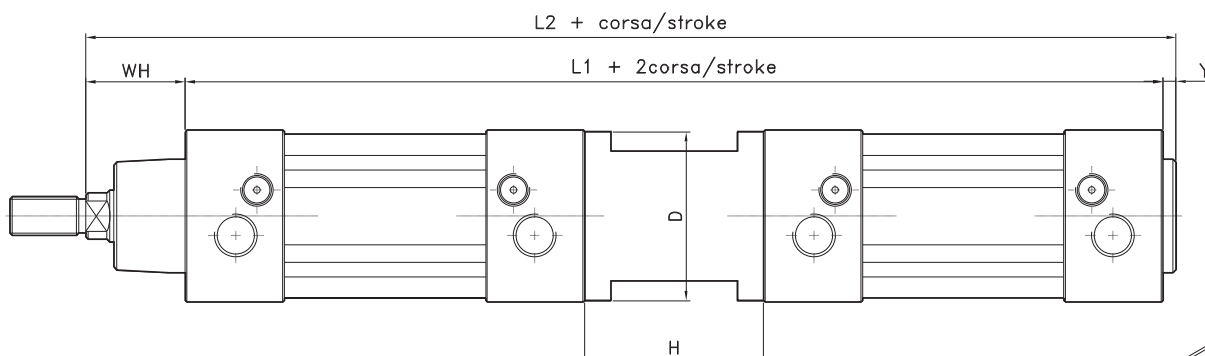

Ø	H	D	WH	L1	L2	Y
32	55	45	26	243 ± 0.4	273	4
40	55	52	30	265 ± 0.7	299	4
50	68	65	37	280 ± 0.7	321	4
63	68	75	37	314 ± 0.8	351	4
80	92	95	46	348 ± 0.8	398	4
100	92	115	51	368 ± 1	423	4
125	120	140	65	440 ± 1	510	5

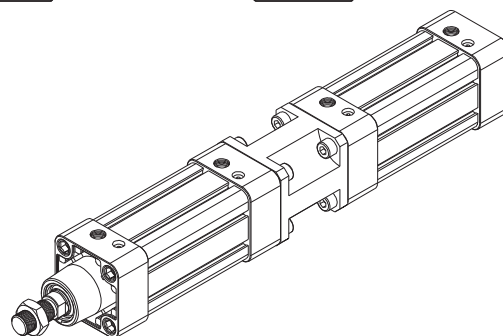

TANDEM CONTRAPPOSTI
TANDEM CONTRASTED

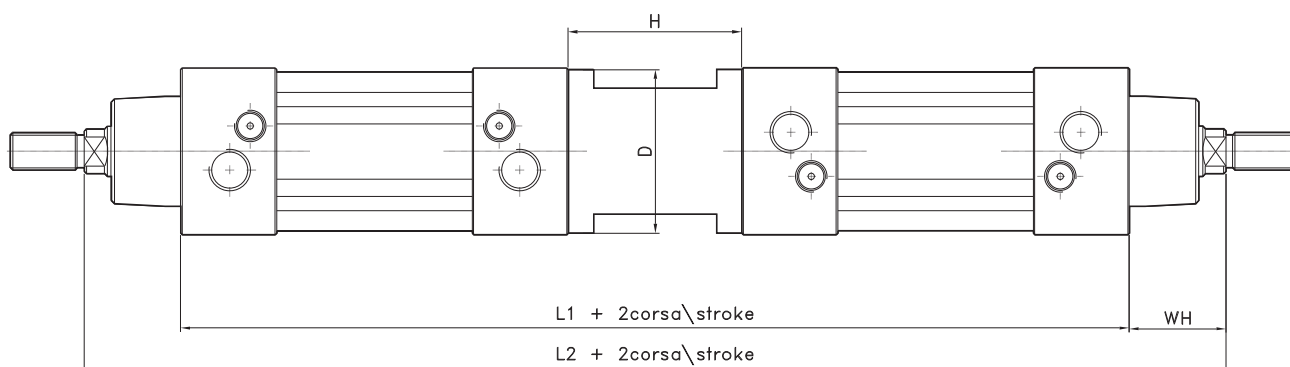

Ø	H	D	WH	L1	L2
32	55	45	26	243 ± 0.4	295
40	55	52	30	265 ± 0.7	325
50	68	65	37	280 ± 0.7	354
63	68	75	37	310 ± 0.8	384
80	92	95	46	348 ± 0.8	440
100	92	115	51	368 ± 1	470
125	120	140	65	440 ± 1	570

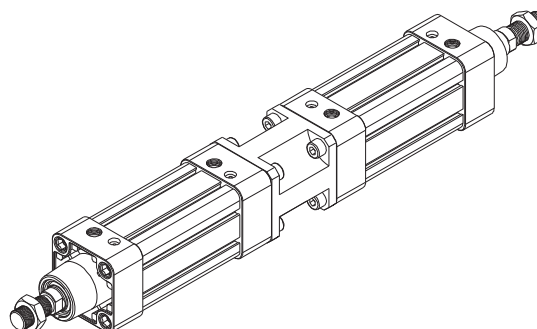

CON SOFFIETTO
WITH RUBBER BELLOW

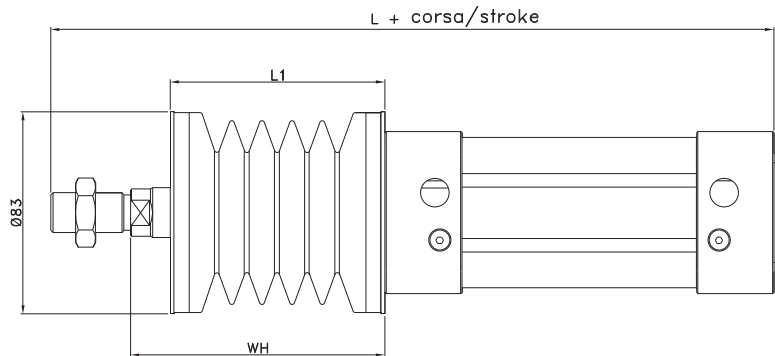
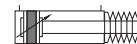

Ø	STROKE <400 mm			STROKE <800 mm			STROKE <1200 mm		
	L	L1	WH	L	L1	WH	L	L1	WH
32	222	90	106	274	142	158	332	200	216
40	235	90	106	287	142	158	345	200	216
50	244	90	106	296	142	158	354	200	216
63	259	90	106	311	142	158	369	200	216
80	274	90	106	326	142	158	384	200	216
100	284	90	106	336	142	158	394	200	216

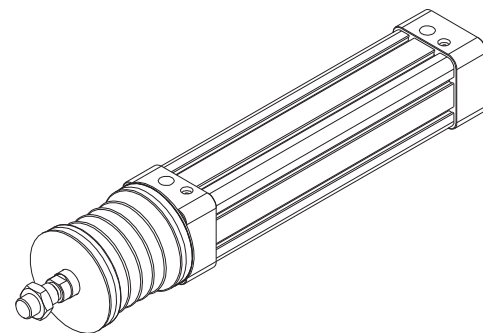

CON BLOCCASTELO SERIE BS MONTATO
WITH ROD LOCK BS SERIES ASSEMBLED

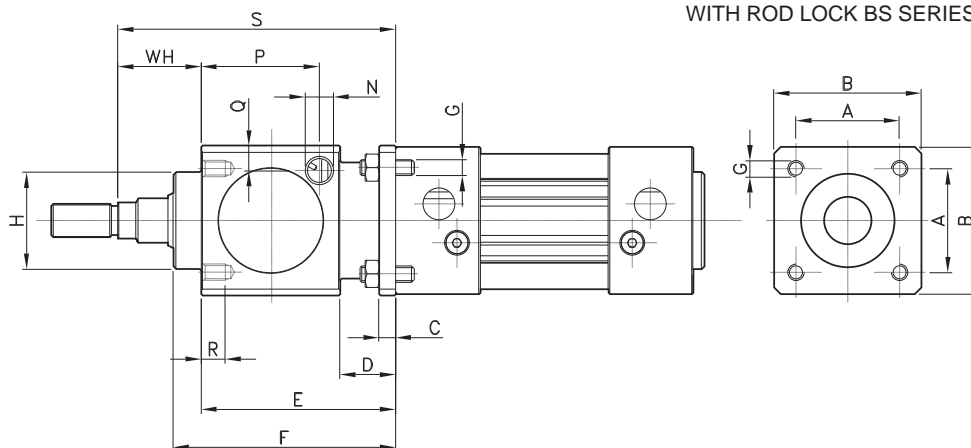

Ø	A	B	C	D	E	F	G	H	N	P	Q	R	S	T
32	32.5	47	6	20	60	67.5	M6	30	1/8"G	33.25	9	8	86	60
40	38	54	6	20	70	80	M6	34.9	1/8"G	42.5	9	8	100	70
50	46.5	65	8	24	90	100	M8	40	1/8"G	58	12.5	12	127	90
63	56.5	75	8	24	90	100	M8	45	1/8"G	59	17.5	12	127	90
80	72	95	12	32	110	120	M10	45	1/4"G	69	17.5	16	156	110
100	89	114	12	32	110	120	M10	55	1/4"G	69	20	16	161	110
125	110	138	20	45	140	156	M12	60	1/4"G	84.5	19	20	205	140

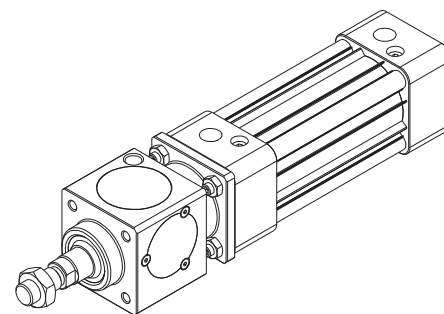

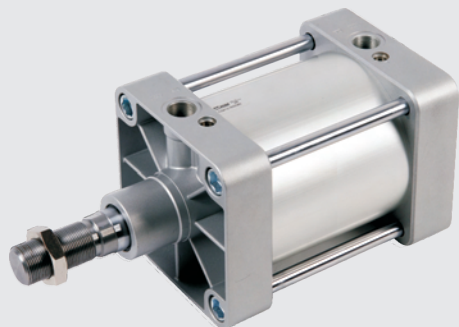

I cilindri Airwork sono realizzati rispettando la normativa ISO 15552 ed hanno alesaggi compresi tra 160 e 250 mm.
Doppio effetto, ammortizzati e magnetici sono indicati dove è richiesta precisione ed affidabilità.
Possibili realizzazioni speciali a disegno e guarnizioni in Viton per alte temperature.

Airwork's cylinders series CW are produced respecting norm ISO 15552 and have bores comprised between 160 and 250 mm. Double effect, cushioned and magnetic they are indicated to you where precision is demanded.
Are available special version with VITON seals.

CHIAVE DI CODIFICA / KEY TO TYPE NUMBER

CQ 00 2 000 0000

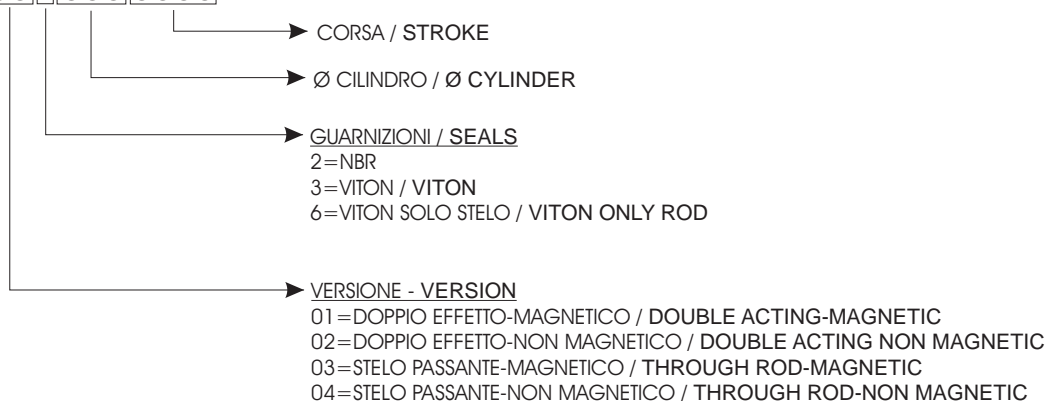

VERSIONE - VERSION

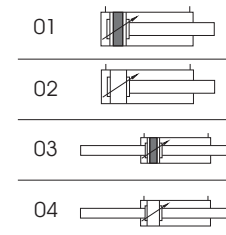

DATI TECNICI / TECHNICAL DATA

Alesaggi - Sizes	Ø160-200-250
Corse standard - Standard strokes	mm 25-50-80-100-125-160-200-250-320-350-400-500-600-700-800-900-1000
Fluido - Fluid	Aria con o senza lubrificazione - Lubricated or non lubricated air
Temperatura di esercizio - Operating temperature range	Poliuretano : -20C°+80C° / Viton: -10C°+150C°
Pressione massima di esercizio - Max operating pressure	10 bar
Forze sviluppate - Force	pag.dati tecnici / technical informations page
Consumo aria - Air consumption	pag.dati tecnici / technical informations page

COMPONENTI / COMPONENTS

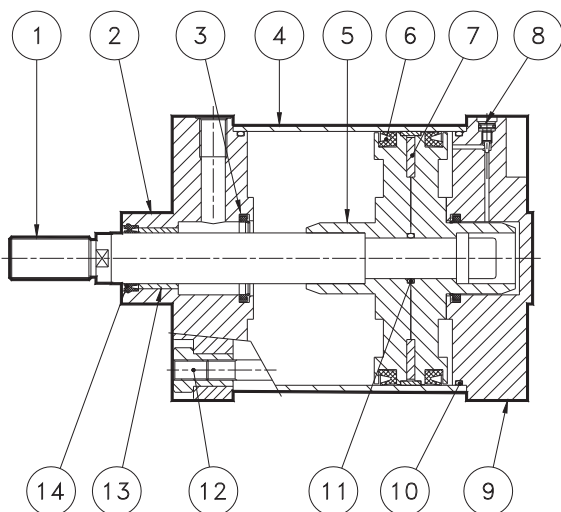

pos.	descrizione / description	materiale / material
1	stelo / rod	acciaio C40 cromato / steel C40 Chromed
2	testata ant. / front cap	alluminio / aluminium
3	guarn. amm. / cushion seal	NBR
4	tubo / tube	alluminio / aluminium
5	pistone / piston	alluminio / aluminium
6	guarnizione pist. / seal piston	NBR
7	magnete / magnet	plastroferrite
8	vite amm. / cushion screw	Ot 58
9	testata post. / rear cap	alluminio / aluminium
10	o-ring	NBR
11	o-ring	NBR
12	viti fiss. / fixing screw	acciaio / steel
13	bussola guida / guide bush	bronzo / bronze
14	guarnizione stelo / rod seal	NBR

DOPPIO EFFETTO
DOUBLE ACTING

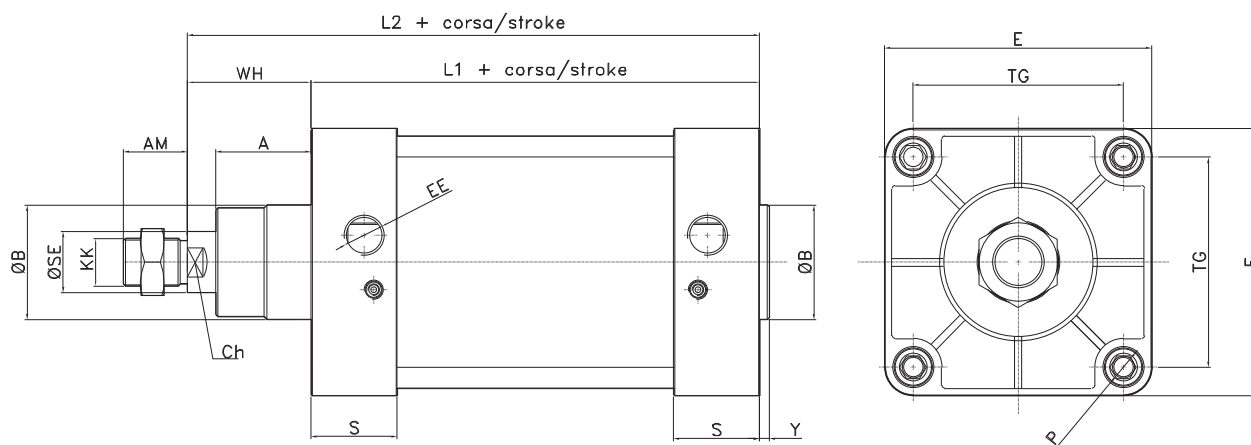
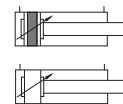

Ø	A	AM	ØB	E	EE	Y	KK	L1	L2	P	S	ØSE	TG	WH	Ch
160	55	72	65	180	G3/4"	6	M36x2	180 ± 1	260	M16	50	40	140	80	36
200	67	72	75	220	G3/4"	8	M36x2	180 ± 1	275	M16	50	40	175	95	36
250	75	84	90	270	G1"	8	M42x2	200 ± 1	305	M20	60	50	220	105	46

STELO PASSANTE
THROUGH ROD

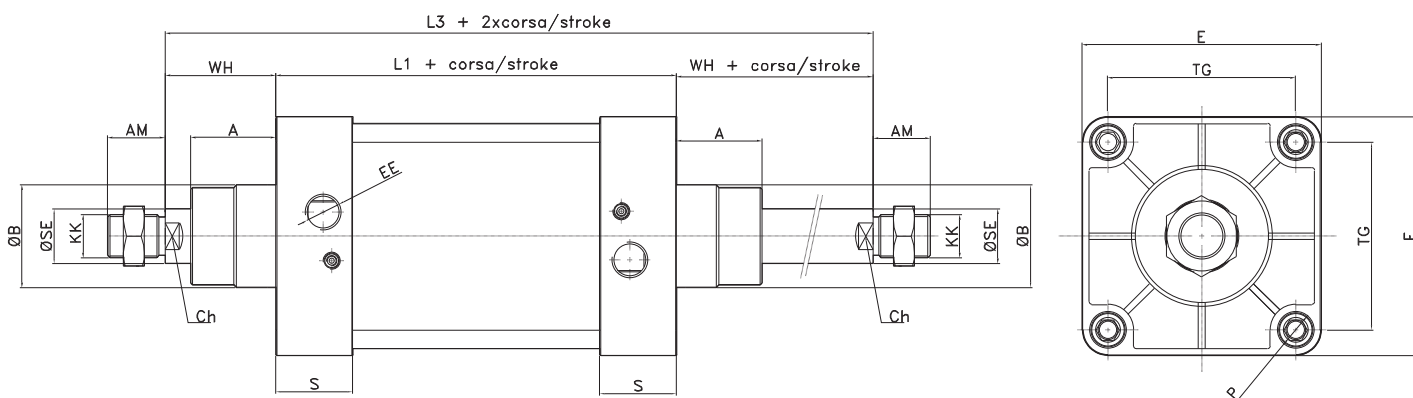
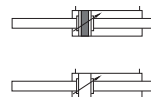

Ø	A	AM (± 0.2)	B e11	E	EE	KK	L1	L3	P	S	SE Ø	TG	WH	Ch
160	55	72	65	180	G3/4"	M36x2	180 ± 1	340 ± 1	M16	50	40	140	80	36
200	67	72	75	220	G3/4"	M36x2	180 ± 1	370 ± 1	M16	50	40	175	95	36
250	75	84	90	270	G1"	M42x2	200 ± 1	410 ± 1	M20	60	50	220	105	46



I cilindri ad aste gemellate vengono utilizzati nel caso sia indispensabile la non rotazione del movimento lineare dello stelo del cilindro.
Le taglie disponibili sono: 32,40,50,63,80,100.

The cylinders twin rods are used when it's necessary that the rod doesn't make any rotation.

The sizes available are : 32 , 40 , 50 , 63 , 80 , 100

CHIAVE DI CODIFICA / KEY TO TYPE NUMBER

CA_00_1_000_0000

- CORSA / STROKE
- Ø CILINDRO / Ø CYLINDER
- GUARNIZIONI / SEALS
1=POLIURETANO / POLYURETHANE
3=VITON / VITON
6=VITON SOLO STELO / VITON ONLY ROD
- VERSIONE - VERSION
01 =DOPPIO EFFETTO-MAGNETICO / DOUBLE ACTING-MAGNETIC
02=DOPPIO EFFETTO-NON MAGNETICO / DOUBLE ACTING NON MAGNETIC
03=STELO PASSANTE-MAGNETICO / THROUGH ROD-MAGNETIC
04=STELO PASSANTE-NON MAGNETICO / THROUGH ROD-NON MAGNETIC
07=CON STELO INOX-MAGNETICO / WITH INOX ROD-MAGNETIC
08=CON STELO INOX-NON MAGNETICO / WITH INOX ROD-NON MAGNETIC

VERSIONE - VERSION

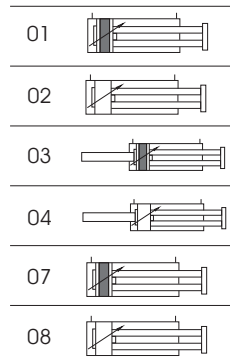

DATI TECNICI / TECHNICAL DATA

Alesaggi - Sizes	Ø32-40-50-63-80-100
Corse standard - Standard strokes	mm 25-50-80-100-125-160-200-250-320-350-400-500
Fluido - Fluid	Aria con o senza lubrificazione - Lubricated or non lubricated air
Temperatura di esercizio - Operating temperature range	Poliuretano : -20C°+80C° / Viton: -10C°+150C°
Pressione massima di esercizio - Max operating pressure	10 bar
Forze sviluppate - Force	pag.datì tecnici / technical informations page
Consumo aria - Air consumption	pag.datì tecnici / technical informations page

DIAGRAMMA DI CARICHI / LOAD DIAGRAM

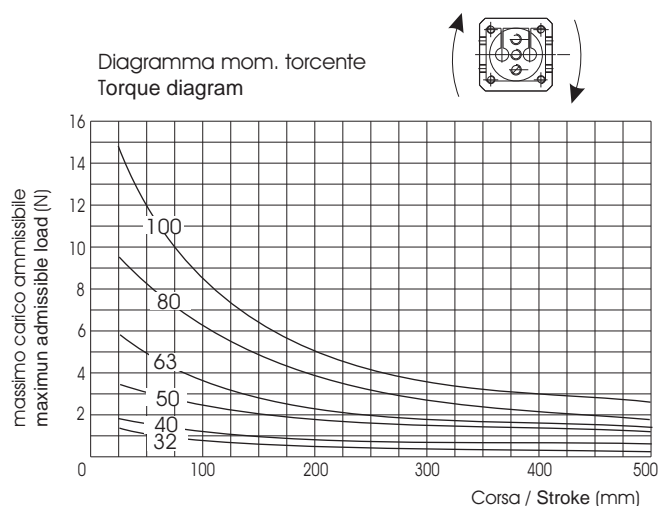
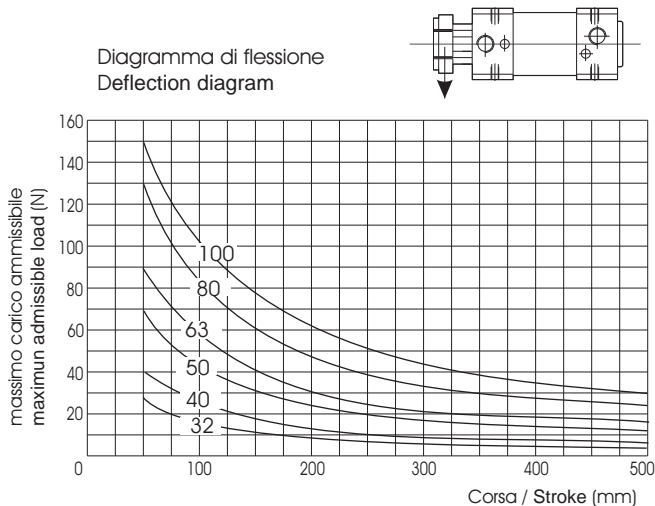

DOPPIO EFFETTO
DOUBLE ACTING

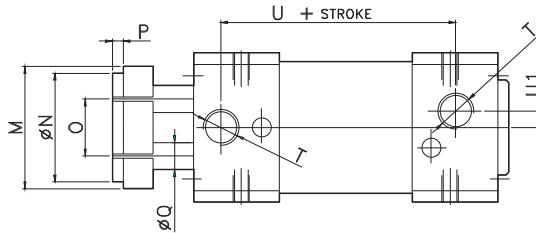
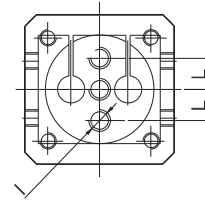
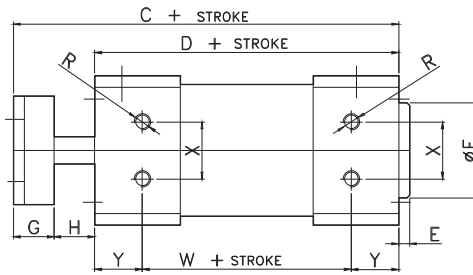
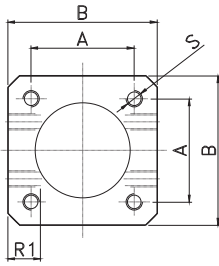
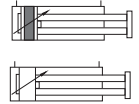

Ø	A	B	C	D	E	ØF	G	H	I	L	M	ØN	O	P	ØQ	R	R1	S	T	U	U1	W	X	Y
32	32.5	45	128	102	4	30	15	11	M6	9.5	40	32	18	4	8	M5	8	M6	G1/8	78	4.5	72	16	15
40	38	55	142	112	4	35	15	15	M8	11.5	45	40	21	4	10	M6	10	M6	G1/4	86.5	6	77	21	17.5
50	46.5	65	151	117	4	40	18	16	M8	15	55	50	26	5	12	M8	10	M8	G1/4	82.5	8.5	85	24	16
63	56.5	80	161	125	4	45	22	14	M10	19	70	63	35	5	16	M8	10	M8	G3/8	89.5	8.5	89	33	18
80	72	100	174	136	4	45	22	16	M12	25	95	80	46	5	20	M10	13	M10	G3/8	100	8.5	98	40	19
100	89	115	181	143	4	55	22	16	M12	35	110	100	70	5	20	M10	13	M10	G1/2	106	10	105	58	19

STELO PASSANTE
THROUGH ROD

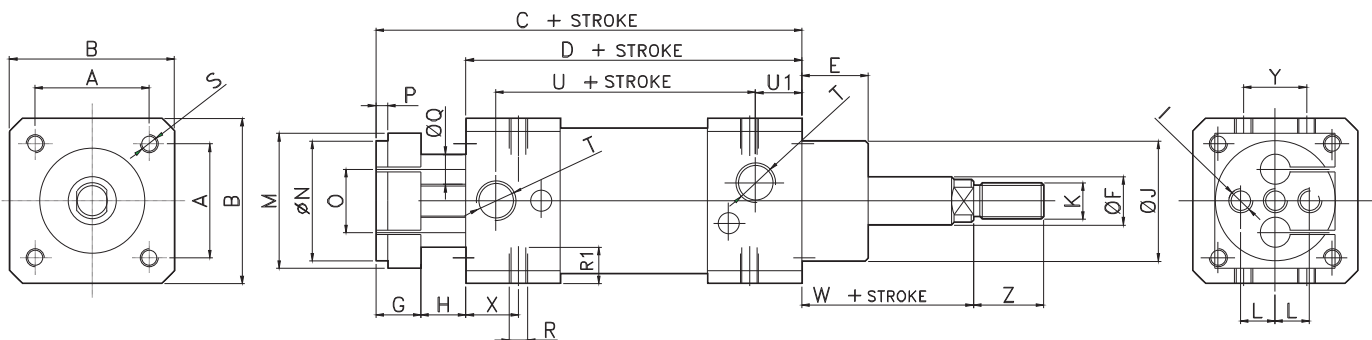
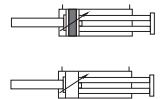

Ø	A	B	C	D	E	ØF	G	H	I	ØJ	K	L	M	ØN	O	P	ØQ	R	R1	S	T	U	U1	W	X	Y
32	32.5	45	128	102	20	12	15	11	M6	30	M10x1.25	9.5	40	32	18	4	8	M5	8	M6	G1/8	77.5	4.5	26	15	16
40	38	55	142	112	22	16	15	15	M8	35	M12x1.25	11.5	45	40	21	4	10	M6	10	M6	G1/4	86	6	30	17.5	21
50	46.5	65	151	117	28	20	18	16	M8	40	M16x1.5	15	55	50	26	5	12	M8	10	M8	G1/4	82.5	8.5	37	16	24
63	56.5	80	161	125	28	20	22	14	M10	45	M16x1.5	19	70	63	35	5	16	M8	10	M8	G3/8	89.5	8.5	37	18	33
80	72	100	174	136	34	25	22	16	M12	45	M20x1.5	25	95	80	46	5	20	M10	13	M10	G3/8	100	8.5	46	19	40
100	89	115	181	143	38	25	22	16	M12	55	M20x1.5	35	110	100	70	5	20	M10	13	M10	G1/2	102	10	51	19	58



I CILINDRI COMPATTI AIRWORK sono, grazie alla loro compattezza, particolarmente adatti per impieghi in piccoli spazi.
Questi cilindri grazie al loro tipo di costruzione, garantiscono buone caratteristiche di stabilità. Gli alesaggi sono compresi tra 16 e 100 e hanno interassi di fissaggio a normativa ISO.

AIRWORK's COMPACT CYLINDERS series CM are particularly suitable for the use in small spaces thanks to their reduced dimensions, and can grant at the same time excellent characteristics of stability. The available bores are comprised between 16 e 100, and the fixing complies to the ISO norms.

CHIAVE DI CODIFICA / KEY TO TYPE NUMBER

CM,00 1 0,000,000



VERSIONE / VERSION

- 01 = DOPPIO EFFETTO MAGNETICO / DOUBLE ACTING MAGNETIC
- 03 = D.E. MAGNETICO STELO PASSANTE / D.A. MAGNETIC THROUGH ROD
- 13 = SEMPLICE EFFETTO MAG. MOLLA POST. / SINGLE ACTING MAG. REAR SPRING
- 15 = SEMPLICE EFFETTO MAG. MOLLA ANT. / SINGLE ACTING MAG. FRONT SPRING
- 29 = D.E. MAG. ANTI-ROTAZIONE / D.A. MAG. NON ROTATING DEVICE
- 31 = D.E. MAG. ANTI-ROTAZIONE STELO PASSANTE / D.A. MAG. NON ROTATING DEVICE THROUGH ROD

Per versioni speciali, contattare in nostro ufficio commerciale
For special versions, please contact our sales department.

VERSIONE - VERSION

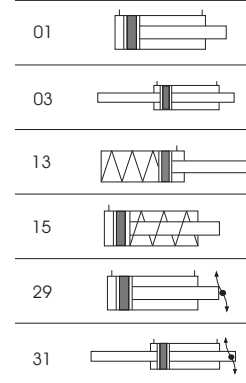

DATI TECNICI / TECHNICAL DATA

Alesaggi - Sizes	Ø16-20-25-32-40-50-63-80-100
Corse standard - Standard strokes	mm 5-10-15-20-25-30-40-50-60-70-80-90-100-125-160-200-250
Fluido - Fluid	Aria con o senza lubrificazione - Lubricated or non lubricated air
Temperatura di esercizio - Operating temperature range	-20C° / +80C°
Pressione massima di esercizio - Max operating pressure	10 bar
Forze sviluppate - Force	pag. dati tecnici / technical informations page
Consumo aria - Air consumption	pag. dati tecnici / technical informations page

COMPONENTI / COMPONENTS

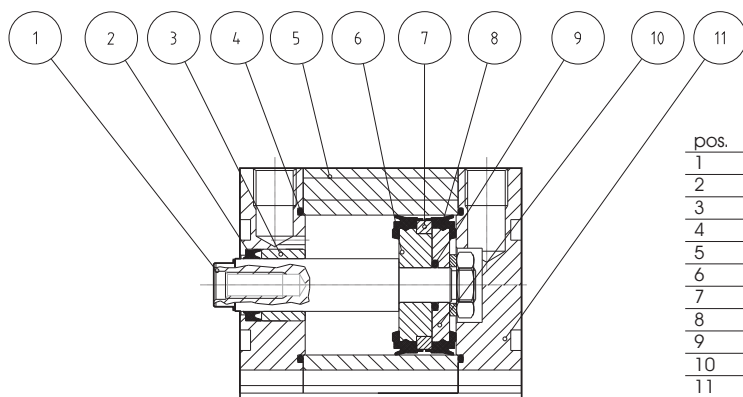

pos.	descrizione / description	materiale / material
1	stelo / rod	acciaio C40 cromato / steel C40 Chromed
2	guarnizione stelo / rod seal	poliuretano / polyurethane
3	bussola guida / guide bush	bronzo / bronze
4	o-ring	NBR
5	tubo / tube	alluminio / aluminium
6	pistone / piston	alluminio / aluminium
7	magnete / magnet	plastoferrite
8	guarnizione pist. / seal piston	poliuretano / polyurethane
9	o-ring	NBR
10	pistone / piston	alluminio / aluminium
11	testata / cap	alluminio / aluminium

Ø16-25

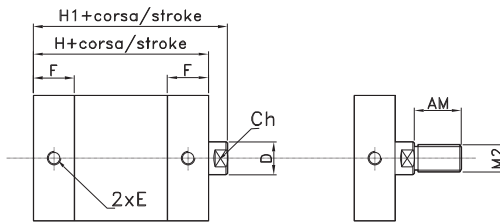
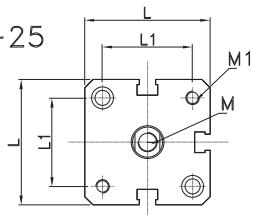

DOPPIO EFFETTO
DOUBLE ACTING

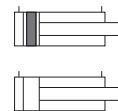

Ø32-100

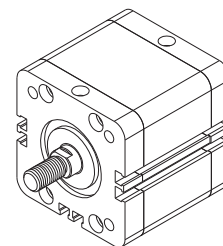
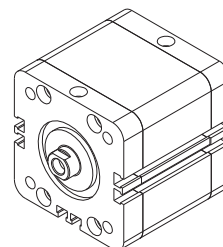
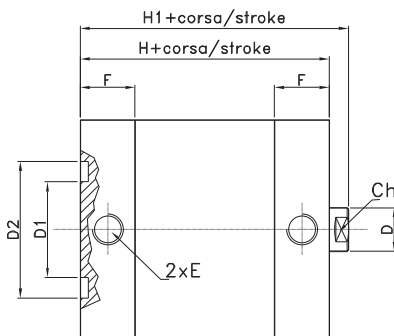
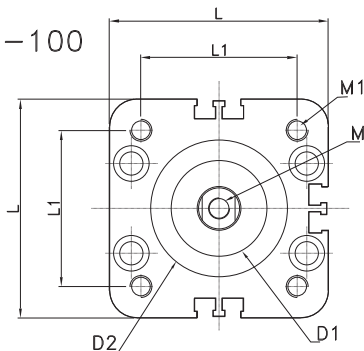

Ø	D ø	D1 ø	D2 ø	E	F	H	H1	L	L1	M	M1	M2	AM	Ch
16	8	-	-	M5	11	35	40	29	18	M4	M4	M6	12	7
20	10	-	-	M5	12	37	43	35.5	22	M6	M5	M8	16	9
25	10	-	-	M5	12	39	45	39.5	26	M6	M5	M8	16	9
32	12	20.5	30	G1/8	15	45	50	47.5	32.5	M8	M6	M10x1.25	19	10
40	12	25.5	35	G1/8	14.5	45	51	56.5	38	M8	M6	M10x1.25	19	10
50	16	30.5	40	G1/8	14.5	45	53	66.5	46.5	M10	M8	M12x1.25	22	13
63	16	35	45	G1/8	14.5	50	57	79.5	56.5	M10	M18	M12x1.25	22	13
80	20	35	45	G1/8	16	55	63	100	72	M12	M10	M16x1.5	28	17
100	20	45	55	G1/4	19.5	67	76	120	89	M12	M10	M16x1.5	28	17

Ø16-25

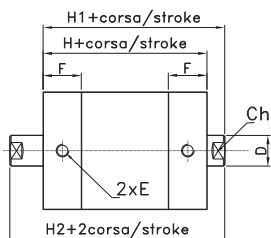
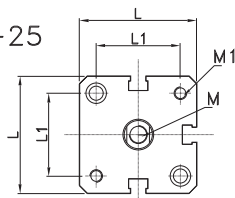

STELO PASSANTE
THROUGH ROD

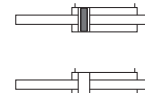

Ø32-100

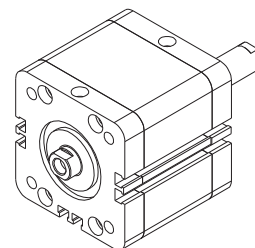
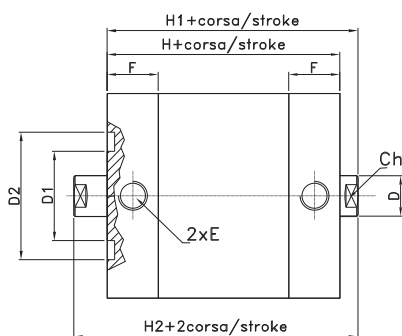
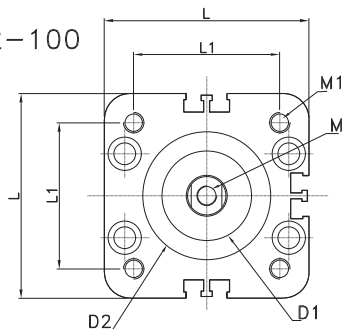

Ø	D ø	D1 ø	D2 ø	E	F	H	H1	H2	L	L1	M	M1	Ch
16	8	-	-	M5	11	35	40	45	29	18	M4	M4	7
20	10	-	-	M5	12	37	43	49	35.5	22	M6	M5	9
25	10	-	-	M5	12	39	45	51	39.5	26	M6	M5	9
32	12	20.5	30	G1/8	15	45	50	55	47.5	32.5	M8	M6	10
40	12	25.5	35	G1/8	14.5	45	51	57	56.5	38	M8	M6	10
50	16	30.5	40	G1/8	14.5	45	53	61	66.5	46.5	M10	M8	13
63	16	35	45	G1/8	14.5	50	57	64	79.5	56.5	M10	M18	13
80	20	35	45	G1/8	16	55	63	71	100	72	M12	M10	17
100	20	45	55	G1/4	19.5	67	76	85	120	89	M12	M10	17

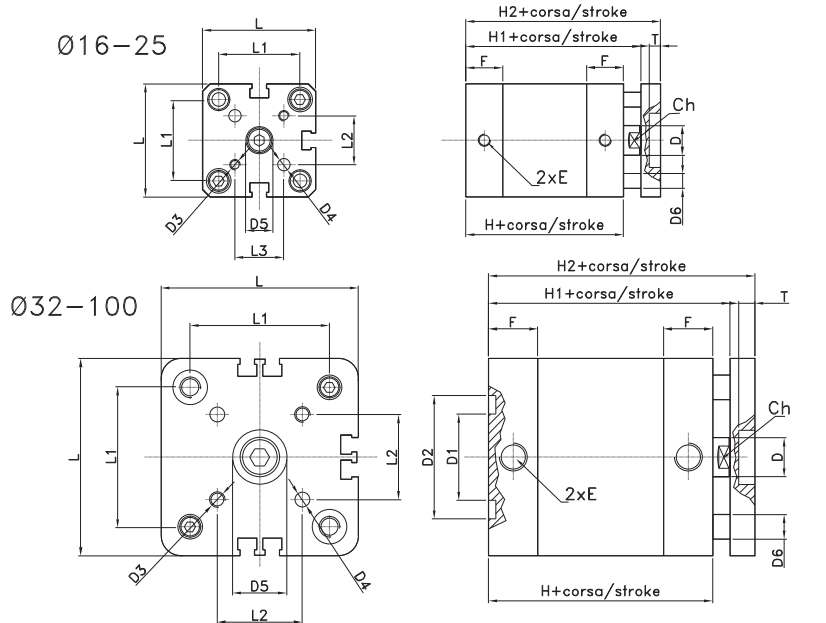

ANTI ROTAZIONE
NON ROTATING DEVICE

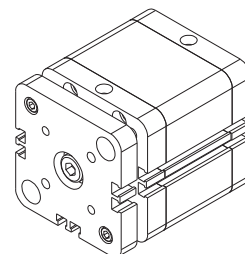
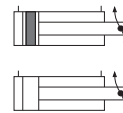

Ø	D	D1	D2	D3	D4	D5	D6	E	F	H	H1	H2	L	L1	L2	T	Ch
16	8	-	-	M4	4	11	5	M5	11	35	40	48	29	18	10	5	7
20	10	-	-	M4	4	11	5	M5	12	37	43	51	35.5	22	12	5	9
25	10	-	-	M4	5	14	6	M5	12	39	45	53	39.5	26	15.6	5	9
32	12	20.5	30	M5	5	17	6	G1/8	15	45	50	60	47.5	32.5	19.8	6.5	10
40	12	25.5	35	M5	5	17	8	G1/8	14.5	45	51	61	56.5	38	23.3	6.5	10
50	16	30.5	40	M6	6	22	10	G1/8	14.5	45	53	65	66.5	46.5	29.7	7.5	13
63	16	35	45	M6	6	22	10	G1/8	14.5	50	57	69	79.5	56.5	35.4	7.5	13
80	20	35	45	M8	8	28	14	G1/8	16	55	63	77	100	72	46	9	17
100	20	45	55	M10	10	30	14	G1/4	19.5	67	76	90	120	89	56.5	10	17

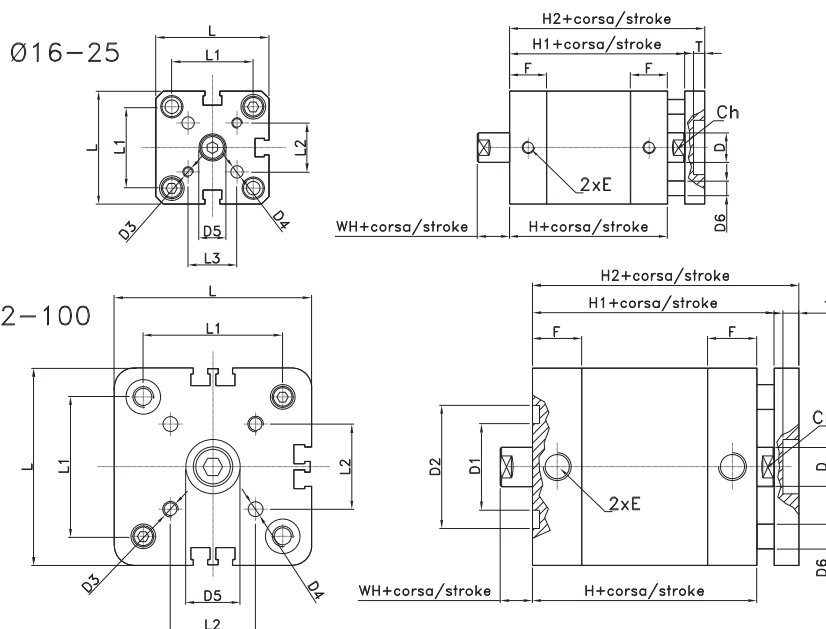

STELO PASSANTE ANTI ROTAZIONE
THROUGH ROD NON ROTATING DEVICE

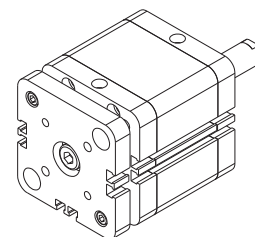
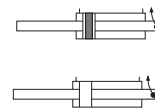

Ø	D	D1	D2	D3	D4	D5	D6	E	F	H	H1	H2	L	L1	L2	T	WH	Ch
16	8	-	-	M4	4	9	5	M5	11	35	40	48	29	18	10	5	5	7
20	10	-	-	M4	4	11	5	M5	12	37	43	51	35.5	22	12	5	6	9
25	10	-	-	M4	5	14	6	M5	12	39	45	53	39.5	26	15.6	5	6	9
32	12	20.5	30	M5	5	17	6	G1/8	15	45	50	60	47.5	32.5	19.8	6.5	5	10
40	12	25.5	35	M5	5	17	8	G1/8	14.5	45	51	61	56.5	38	23.3	6.5	6	10
50	16	30.5	40	M6	6	22	10	G1/8	14.5	45	53	65	66.5	46.5	29.7	7.5	8	13
63	16	35	45	M6	6	22	10	G1/8	14.5	50	57	69	79.5	56.5	35.4	7.5	7	13
80	20	35	45	M8	8	28	14	G1/8	16	55	63	77	100	72	46	9	8	17
100	20	45	55	M10	10	30	14	G1/4	19.5	67	76	90	120	89	56.5	10	9	17

MONTAGGIO ACCESSORI / MOUNTING ACCESSORIES

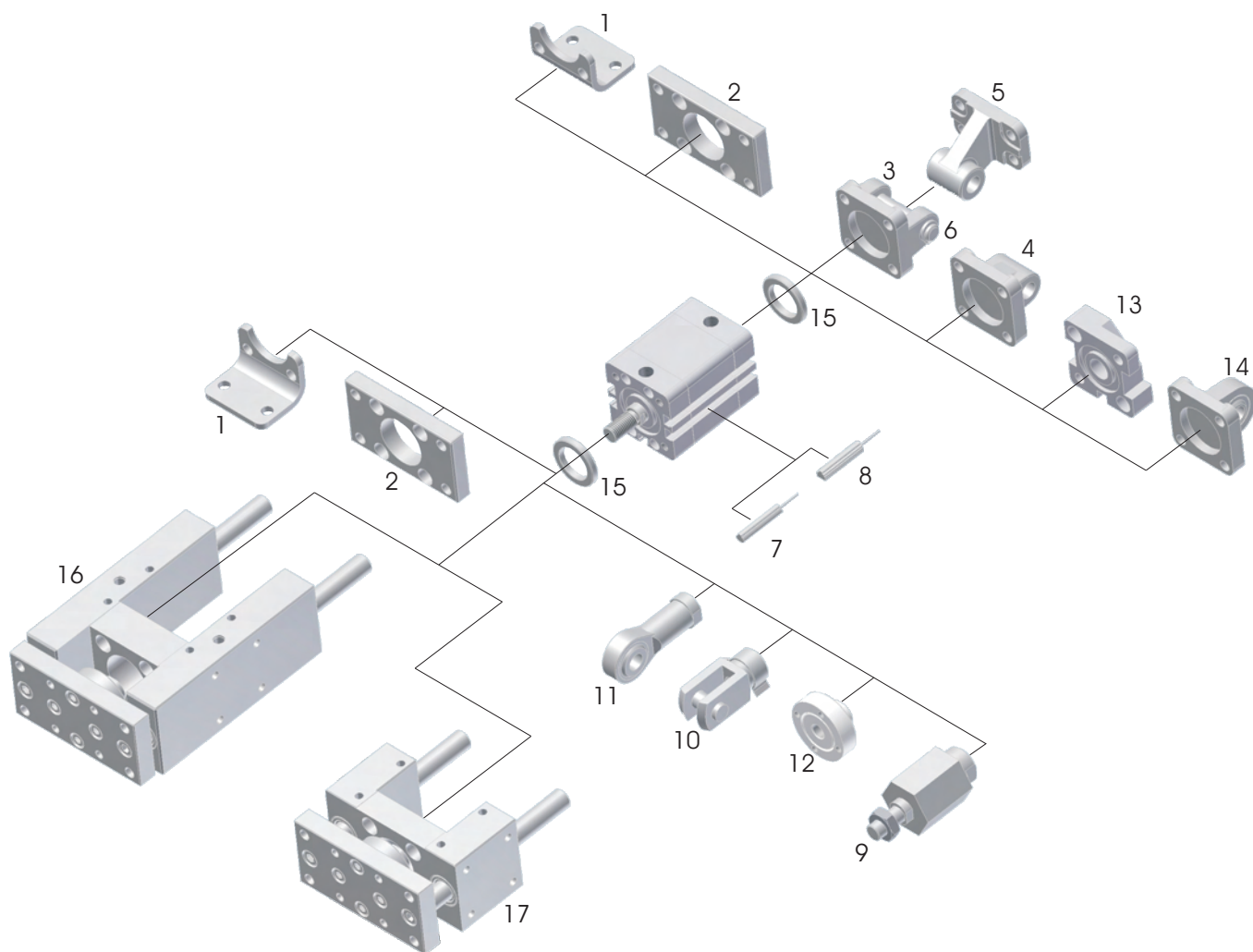

1	AR4152...	Piedino / Pedestal
2	AR4151...	Flangia / Flange
3	AR4147...	Cerniera femmina / Female hinge
4	AR4149...	Cerniera maschio / Male hinge
5	AR4156...	Articolazione a squadra / Square joint
6	AR4150...	Perno per cerniera / Pivot for Hinge
7	AR4019...	Sensore ovale / Oval switch
8	AR4023...	Sensore a T / T switch
9	AR406...	Giunto autoallineante / Self-aligning joint
10	AR406...	forcella / yoke
11	AR406...	Testa a snodo / Rod ends
12	KU0017...	Giunto flottante / floating joint
13	AR43976...	Piastra coll.per tandem / Plate for tandem
14	AR4226...	Cerniera maschio con testa snodata / Male hinge with articulated head
15	AR43977...	Anello di centraggio / Centring ring for fixing
16	UG2014....	Unità guida ad H / Guide unit H type
17	UG2008...	Unità guida ad U / Guide unit U type

Materiale: Acciaio
Material: Steel

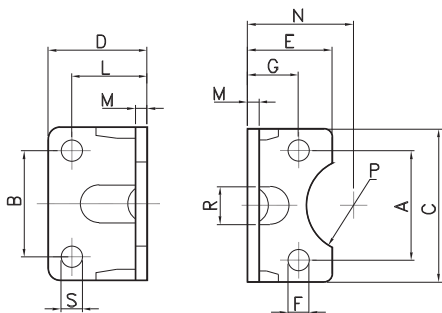
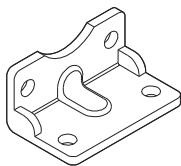

PIEDINO / PEDESTAL

CODE	Ø
AR4152032	32
AR4152040	40
AR4152050	50
AR4152063	63
AR4152080	80
AR4152100	100
AR4152125	125
AR4152160	160
AR4152200	200
AR4152250	250

con viti di fissaggio, aggiungere "V"
esempio: AR4152032V

with screws for fixing, to add "V"
example: AR4152032V

Ø	A	B	C	D	E	F	G	L	M	N	P	R	S	Peso (g)
32	32.5	32	45	35	30	7	15.75	24	4	32	15	11	7	66
40	38	36	52	36	30	7	17	28	4	36	17.5	15	9	78
50	46.5	45	65	47	36	9	21.75	32	5	45	20	16	9	168
63	56.5	50	75	45	35	9	21.75	32	5	50	22.5	18	9	190
80	72	63	95	55	47	11	27	41	6	63	22.5	17	12	382
100	89	75	115	57	53	11	26.5	41	6	71	27.5	24	14	452
125	110	90	140	70	70	14	35	45	8	90	30	-	16	1090
160	140	115	180	75	100	18	45	60	9	115	32.5	-	18	1188
200	175	135	220	100	100	18	47.5	70	12	135	37.5	-	22	3450
250	220	165	270	100	150	22	55	75	14	165	45	-	26	6600

Materiale: Acciaio
Material: Steel

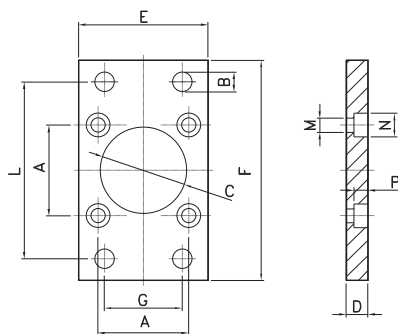
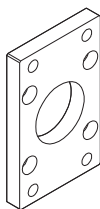

FLANGIA / FLANGE

CODE	Ø
AR4151032	32
AR4151040	40
AR4151050	50
AR4151063	63
AR4151080	80
AR4151100	100
AR4151125	125
AR4151160	160
AR4151200	200
AR4151250	250

con viti di fissaggio, aggiungere "V"
esempio: AR4151032V

with screws for fixing, to add "V"
example: AR4151032V

Ø	A	B	C	D	E	F	G	L	M	N	P	Peso (g)
32	32.5	7	30	10	45	80	32	64	6.5	10.5	6.5	190
40	38	9	35	10	52	90	36	72	6.5	10.5	6.5	246
50	46.5	9	40	12	65	110	45	90	8.5	13.5	8.5	478
63	56.5	9	45	12	75	120	50	100	8.5	13.5	8.5	622
80	72	12	45	16	95	150	63	126	10.5	16.5	10.5	1430
100	89	14	55	16	115	170	75	150	10.5	16.5	10.5	1986
125	110	16	60	20	140	205	90	180	13.5	20	12.5	3750
160	140	18	65	20	180	260	115	230	17	25	16.5	6350
200	175	22	75	25	220	300	135	270	17	25	16.5	11350
250	220	26	90	25	280	390	165	330	22.5	33	20	20100

Materiale: Alluminio
Material: Aluminium

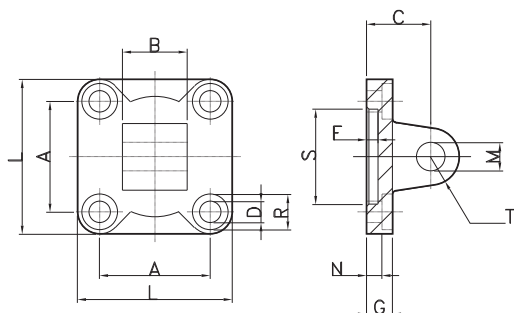
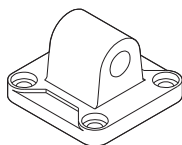

CERNIERA MASCHIO / MALE HINGE

CODE	Ø
AR4149032	32
AR4149040	40
AR4149050	50
AR4149063	63
AR4149080	80
AR4149100	100
AR4149125	125
AR4149160	160
AR4149200	200
AR4149250	250

con viti di fissaggio, aggiungere "V"
esempio: AR4149032V

with screws for fixing, to add "V"
example: AR4149032V

Ø	A	B	C	D	F	G	L	M	N	R	S	T	Peso (g)
32	32.5	26	22	6.6	5	9	45	10	5.5	11	30	10	54
40	38	28	25	6.6	5	9	52	12	5.5	11	35	12	76
50	46.5	32	27	9	5	11	65	12	6.5	15	40	12	124
63	56.5	40	32	9	5	11	75	16	6.5	15	45	16	212
80	72	50	36	11	5	14	95	16	10	18	45	16	420
100	89	60	41	11	5	14	115	20	10	18	55	20	666
125	110	70	50	14	7	20	140	25	10	20	60	25	1264
160	140	90	55	18	7	20	180	30	10	26	65	25	1846
200	175	90	60	18	7	25	220	30	11	26	75	25	2950
250	220	110	70	22	11	25	270	40	=	=	90	40	6200

Materiale: Alluminio
Material: Aluminium

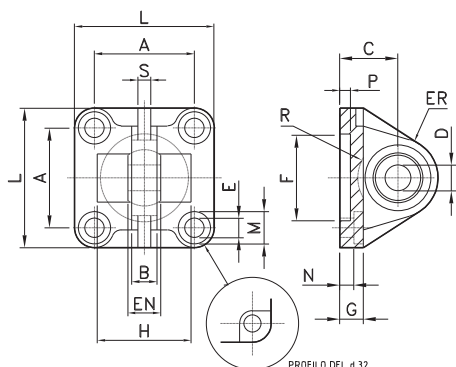
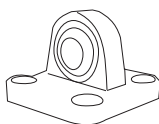

PROFILO DEL Ø 32

CERNIERA MASCHIO CON TESTINA SNODATA
MALE HINGE WITH ARTICULATED HEAD

CODE	Ø
AR4226032	32
AR4226040	40
AR4226050	50
AR4226063	63
AR4226080	80
AR4226100	100
AR4226125	125

con viti di fissaggio, aggiungere "V"
esempio: AR4226032V

with screws for fixing, to add "V"
example: AR4226032V

Ø	A ±0.2	B max	C JS15	D H7	EN -0.1	ER max	F H11	G	E H13	L	M H13	N ±0.2	P	H ±0.5	R ±0.5	Peso (g)
32	32,5	10,5	22	10	14	16	30	9	6,6	45	11	5,5	5	=	=	62
40	38	12	25	12	16	19	35	9	6,6	52	11	5,5	5	=	=	100
50	46,5	15	27	16	21	21	40	11	9	65	15	6,5	5	51	19	180
63	56,5	15	32	16	21	24	45	11	9	75	15	6,5	5	=	=	244
80	72	18	36	20	25	28,5	45	14	11	95	18	10	5	70	24	476
100	89	18	41	20	25	30	55	14	11	115	18	10	5	=	=	646
125	110	25	50	30	37	40	60	20	13,5	140	20	10	7	=	=	1410

Materiale: Alluminio
Material: Aluminium

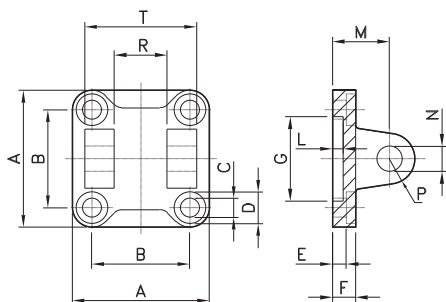
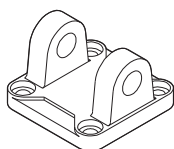

CERNIERA FEMMINA / FEMALE HINGE

CODE	Ø
AR4147032	32
AR4147040	40
AR4147050	50
AR4147063	63
AR4147080	80
AR4147100	100
AR4147125	125
AR4147160	160
AR4147200	200
AR4147250	250

con viti di fissaggio, aggiungere "V"
esempio: AR4147032V

with screws for fixing, to add "V"
example: AR4147032V

Ø	A	B	C	D	E	F	G	L	M	N	P	R	T	Peso (g)
32	45	32,5	6,6	11	5,5	9	30	5	22	10	10	26	45	48
40	52	38	6,6	11	5,5	9	35	5	25	12	12	28	52	75
50	65	46,5	9	15	6,5	11	40	5	27	12	12	32	60	124
63	75	56,5	9	15	6,5	11	45	5	32	16	16	40	70	192
80	95	72	11	18	10	14	45	5	36	16	16	50	90	380
100	115	89	11	18	10	14	55	5	41	20	20	60	110	620
125	140	110	14	20	10	20	60	7	50	25	25	70	130	1180
160	180	140	18	26	10	20	65	7	55	30	25	90	170	1780
200	220	175	18	26	11	25	75	7	60	30	25	90	170	2900
250	270	220	22	-	-	25	90	-	70	40	40	110	200	5800

Materiale: Alluminio
Material: Aluminium

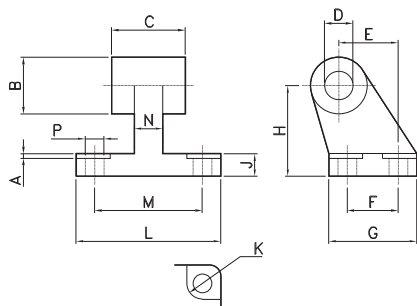
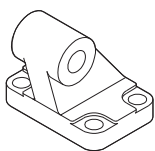

ARTICOLAZIONE A SQUADRA
SQUARE JOINT

CODE	Ø
AR4156032	32
AR4156040	40
AR4156050	50
AR4156063	63
AR4156080	80
AR4156100	100
AR4156125	125
AR4156160	160
AR4156200	200

con viti di fissaggio, aggiungere "V"
esempio: AR4156032V

with screws for fixing, to add "V"
example: AR4156032V

Ø	A	B	C	D	E	F	G	H	J	K	L	M	N	P	Peso (g)
32	1,6	20	26	10	21	18	31	32	8	11	51	38	10	6,6	56
40	1,6	22	28	12	24	22	35	36	10	11	54	41	15	6,6	80
50	1,6	26	32	12	33	30	45	45	12	15	65	50	16	9	142
63	1,6	30	40	16	37	35	50	50	14	15	67	52	16	9	200
80	2,5	30	50	16	47	40	60	63	14	18	86	66	20	11	312
100	2,5	38	60	20	55	50	70	71	17	18	96	76	20	11	510
125	3,2	45	70	25	70	60	90	90	20	20	124	94	30	14	826
160	4	63	90	30	97	88	126	115	25	20	156	118	36	14	2600
200	4	63	90	30	105	90	130	135	30	26	162	122	40	18	3250

Materiale: Acciaio
Material: Steel

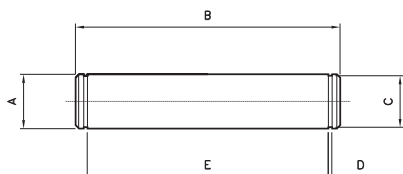
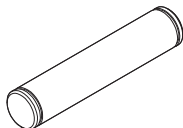

PERNO PER CERNIERA / PIVOT FOR HINGE

CODE	Ø
AR4150032	32
AR4150040	40
AR4150050	50
AR4150063	63
AR4150080	80
AR4150100	100
AR4150125	125
AR4150160	160
AR4150200	200
AR4150250	250

completa di n° 2 seeger
complete of n° 2 seegers

Ø	A	B	C	D	E	Peso (g)
32	10	53	9.6	1.1	46	32
40	12	60	11.5	1.1	53	52
50	12	68	11.5	1.1	61	60
63	16	78	15.2	1.1	71	122
80	16	98	15.2	1.1	91	152
100	20	118	19	1.3	111	290
125	25	139	23.9	1.3	132	530
160	30	178	28.6	1.6	171.5	978
200	30	178	28.6	1.6	171.5	978
250	40	211	37.5	1.85	202	2100

Materiale: Alluminio
Material: Aluminium

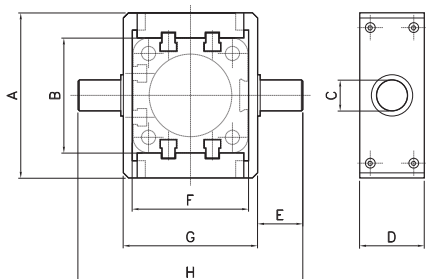
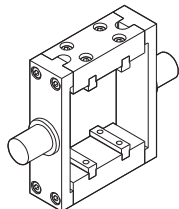

CERNIERA INTERMEDIA PER CY
INTERMEDIATE HINGE FOR CY

CODE	Ø
AR4158032	32
AR4158040	40
AR4158050	50
AR4158063	63
AR4158080	80
AR4158100	100
AR4158125	125

Ø	A	B	C	D	E	F	G	H
32	65	44.6	12	25	17.5	45	52	87
40	74.8	50.8	16	25	21.5	50.8	62	105
50	90.3	60.3	16	25	21.5	60.6	74	117
63	94.5	70.5	20	30	23.5	70	91	138
80	109.3	87.5	20	30	23.5	87.2	111	158
100	134	106.6	25	40	33	106.2	129	195
125	160	132.6	25	40	33	132.1	156.7	222.7

Materiale: Acciaio
Material: Steel

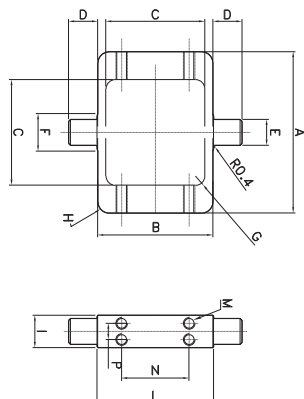
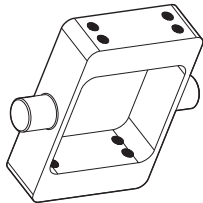

CERNIERA INTERMEDIA PER CZ
INTERMEDIATE HINGE FOR CZ

CODE	Ø
AR4279032	32
AR4279040	40
AR4279050	50
AR4279063	63
AR4279080	80
AR4279100	100
AR4279125	125

Ø	A	B	C	D	E	F	G	H	I	L	M	N	P	Peso (g)
32	70	50	45	12	12	-	5	4	18	50	M5	32.5	7	250
40	78	62	51	16	16	20	5	5	20	63	M5	38	8	410
50	91	74	60.8	16	16	20	6	6	20	75	M6	46.5	8	530
63	94	88	70.5	20	20	25	6	6	25	90	M6	56.5	12	775
80	130	109	87.5	20	20	25	7	7	25	110	M8	72	12	1430
100	145	130	107	25	25	30	8	8	30	132	M8	89	15	1950
125	154	155	133	25	25	32	11	11	32	160	M10	110	15	1600

Materiale: Alluminio
Material: Aluminium

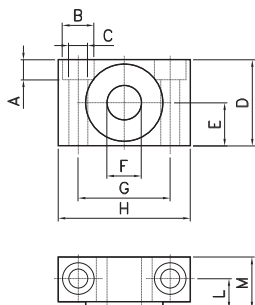
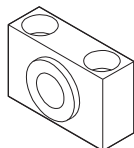

SUPPORTO PER CERNIERA INTERMEDIA
SUPPORT FOR INTERMEDIATE HINGE

CODE	Ø
AR4159032	32
AR4159040	40-50
AR4159063	63-80
AR4159100	100-125

Il codice si riferisce a n°2 pezzi
Con viti di fissaggio, aggiungere "V"
esempio: AR4159032V

The code included n°2 pieces.
With screws for fixing, to add "V"
example: AR4159032V

Ø	A	B	C	D	E	F	G	H	L	M	Peso (g)
32	7	11	6.6	30	15	12	32	46	10.5	18	100
40-50	9	15	9	36	18	16	36	55	12	21	150
63-80	11	18	11	40	20	20	42	65	13	23	234
100-125	13	20	14	50	25	25	50	75	16	28.5	435

Materiale: Acciaio
Material: Steel

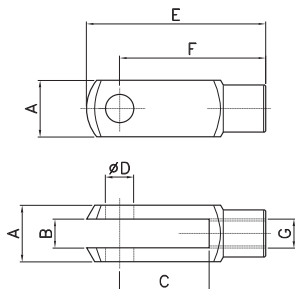
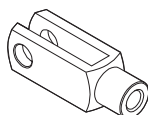

FORCELLA
YOKE

CODE	Ø	
AR40673	32	
AR40674	40	
AR40675	50-63	
AR40676	80-100	
AR40678	125	completo di perno / complete of pivot
AR40679	160-200	completo di perno / complete of pivot

Ø	A	B	C	D	E	F	G	Peso (g)
32	20	10	20	10	52	40	M10x1.25	72
40	24	12	24	12	62	48	M12x1.25	115
50-63	32	16	32	16	83	64	M16x1.5	270
80-100	40	20	40	20	105	80	M20x1.5	550
125	55	30	54	30	148	110	M27x2	1600
160-200	70	35	72	35	188	144	M36x2	3270

Materiale: Acciaio
Material: Steel

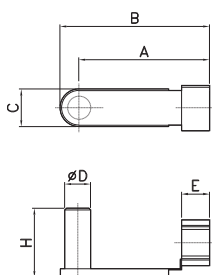
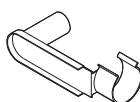

CLIPS PER FORCELLA
CLIPS FOR YOKE

CODE	Ø
AR40683	32
AR40684	40
AR40685	50-63
AR40686	80-100

Ø	A	B	C	D	E	H	Peso (g)
32	37	47	15	10	10	26	19
40	45	54	16	12	12	32	30
50-63	60	73	24	16	14	40	70
80-100	77	91	26.5	20	16	48	130

Materiale: Acciaio
Material: Steel

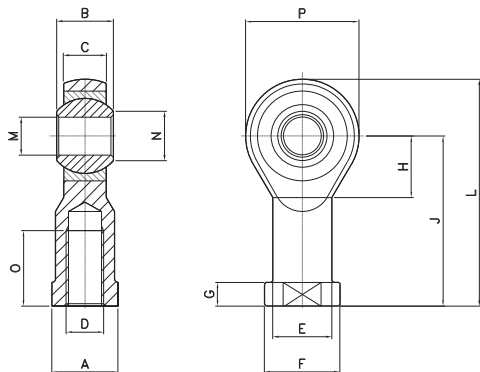

TESTA A SNODO
ROD ENDS

CODE	Ø
AR40660	32
AR40662	40
AR40665	50-63
AR40666	80-100
AR40667	125
AR40669	160-200
AR40668	250

Ø	A	B	C	D	E	F	G	H	J	L	M	N	O	P
32	17	14	10.5	M10x1.25	15	19	6.5	15	43	57	10	12.9	20	28
40	19	16	12	M12x1.25	17.5	22	6.5	17	50	66	12	15.4	22	32
50-63	22	21	15	M16x1.5	22	27	8	23	64	85	16	19.3	28	42
80-100	30	25	18	M20x1.5	27.5	34	10	27	77	102	20	24.3	33	50
125	41	37	25	M27x2	40	50	15	36	110	145	30	34.8	51	70
160-200	50	43	28	M36x2	46	58	17	41	125	165	35	37.7	56	80
250	55	49	33	M42x2	53	65	19	45	142	187.5	40	45.2	60	91

Materiale: Acciaio
Material: Steel

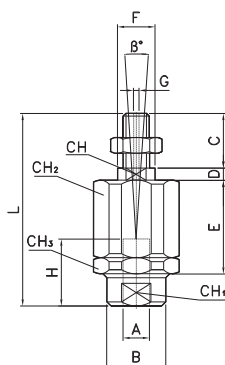
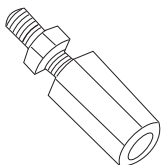

GIUNTO AUTOALLINEANTE
SELF-ALIGNING JOINT

CODE	Ø
AR40689	32
AR40691	40
AR40693	50-63
AR40694	80-100

Ø	A	B	C	D	E	F	G	H	L	CH	CH ₁	CH ₂	CH ₃	β°
32	M10x1.25	22	20	5	35	14	2	20	71	12	19	30	32	10
40	M12x1.25	22	24	5	35	14	2	20	75	12	19	30	32	10
50-63	M16x1.5	32	32	8	54	22	2	32	103	20	30	41	45	10
80-100	M20x1.5	32	40	8	54	22	2	40	119	20	30	41	45	10

Materiale: Acciaio
Material: Steel

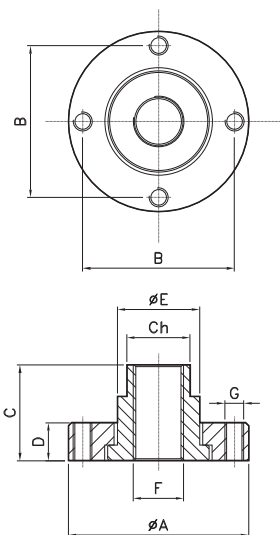
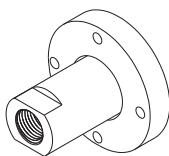

GIUNTO FLOTTANTE
FLOATING JOINT

CODE	Ø
KU0017020	20
KU0017025	25
KU0017032	32
KU0017040	40
KU0017050	50-63
KU0017080	80-100

Ø	ØA	B	C	D	ØE	F	G	Ch
16	28.5	22.5	15	6	11	M5	M5	8
20	31.5	25.5	18	7.5	14	M8	M5	12
25	31.5	25.5	18	7.5	14	M10	M5	12
32	38	31	19	11	17	M10	M5	15
40	38	31	19	11	17	M12	M5	15
50-63	57	48	27	12	26	M16	M6	20
80-100	63	54	27	12	32	M20	M6	26

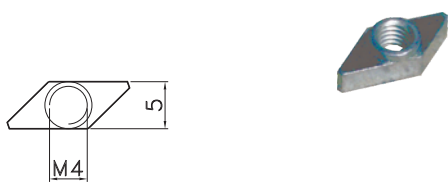

PIASTRINA FISSAGGIO VALVOLA SU CILINDRO CY
VALVE FIXING PLAQUE ON CYLINDER CY
CODE

AR4213	senza viti / without screws
AR4213V	con viti per VY / with screws for VY

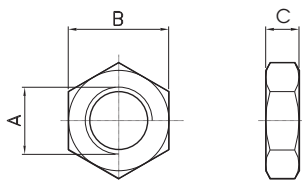

DADO PER STELO
NUT FOR ROD

CODE	Ø	A	B	C
DAD10X1.25	32	M10X1.25	17	8
DAD12X1.25	40	M12X1.25	19	6
DAD16X1.25	50-63	M16X1.5	22	6
DAD20X1.5	80-100	M20X1.5	30	8
DAD27X2	125	M27X2	41	12
DAD36X2	160-200	M36X2	55	18

Materiale: Alluminio
Material: Aluminium

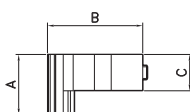
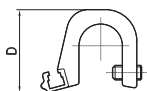
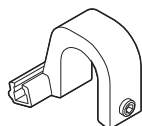

ADATTATORE SENSORE A "T" PER CILINDRO SERIE CW E CQ
ADAPTOR FOR "T" SWITCH FOR CYLINDER SERIES CW AND CQ

CODE	Ø
AR420080	160-200
AR4200125	250

Ø	A	B	C	D
160-200	25	38	15	30
250	25	40	15	35

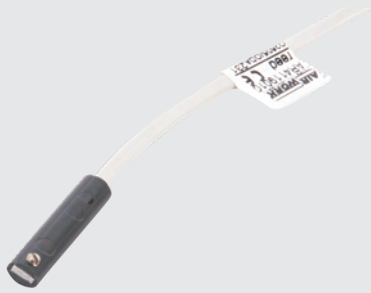

DATI TECNICI / TECHNICAL DATA	REED	HALL
Tipo sensore / Sensor type	Reed NA / NO	PNP NA/NO
Grado di protezione / Protection class	IP 67	IP 67
Temper. Di impiego / Working temp.	-10C° +70C°	-10C° +70C°
Materiale custodia / Housing material	PA	PA
Materiale guaina / Sheath material	PVC	PVC
Tensione di alimentazione / Power supply	3-30 VAC/VDC	Hall 6-30 VDC
Corrente di commutazione / Switching current	0,2 A	0,2 A
Caduta di tensione / ON voltage drop	<3 V	<1 V
Punto di lavoro nominale / Nominal operate poin	20 - 25 AT	40 Gauss (34 - 46 Gauss)
Differenza ON-OFF / ON-OFF differential	5 - 10 AT	5 - 15 Gauss
Tempo inserzione / On time	0,5mS	0,8 uS
Tempo disinserzione / Off time	0,1mS	0,3 uS
Configurazione circuiti / Wiring schematics		
Connettore M8 / M8 connector	4=azzurro / blue 1=marrone / brown	4=nero / black 1=marrone / brown 3=azzurro / blue

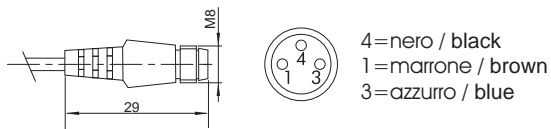
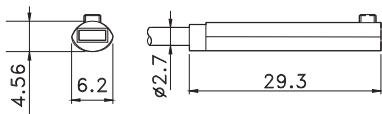

CODE	
AR4019010	REED (MT.2,5) / REED (MT.2,5)
AR4019020	HALL (MT.2,5) / HALL (MT.2,5)
AR4019110	REED + CONNETTORE M8 (CM 30) / REED + M8 CONNECTOR
AR4019120	HALL + CONNETTORE M8 (CM 30) / HALL + M8 CONNECTOR

SISTEMA DI MONTAGGIO / SYSTEM OF ASSEMBLY

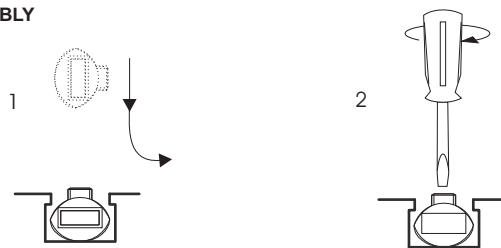

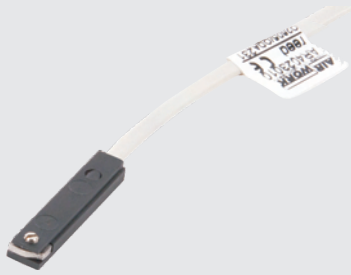

DATI TECNICI / TECHNICAL DATA

	REED	HALL
Tipo sensore / Sensor type	Reed NA / NO	PNP NA/NO
Grado di protezione / Protection class	IP 67	IP 67
Temper. Di impiego / Working temp.	-10C° +70C°	-10C° +70C°
Materiale custodia / Housing material	PA	PA
Materiale guaina / Sheath material	PVC	PVC
Tensione di alimentazione / Power supply	3-30 VAC/VDC	Hall 6-30 VDC
Corrente di commutazione / Switching current	0,2 A	0,2 A
Caduta di tensione / ON voltage drop	<3 V	<1 V
Punto di lavoro nominale / Nominal operate poin	20 - 25 AT	40 Gauss (34 - 46 Gauss)
Differenza ON-OFF / ON-OFF differential	5 - 10 AT	5 - 15 Gauss
Tempo inserzione / On time	0,5mS	0,8 uS
Tempo disinserzione / Off time	0,1mS	0,3 uS
Configurazione circuiti / Wiring schematics		
Connettore M8 / M8 connector		

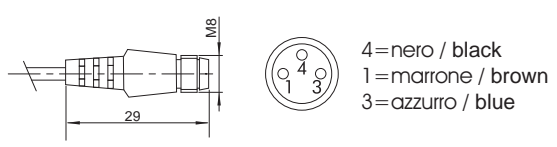
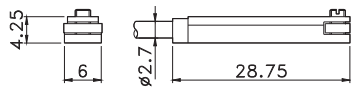

CODE

AR4023010	REED (MT.2,5) / REED (MT.2,5)
AR4023020	HALL (MT.2,5) / HALL (MT.2,5)
AR4023110	REED + CONNETTORE M8 (CM 30) / REED + M8 CONNECTOR
AR4023120	HALL + CONNETTORE M8 (CM 30) / HALL + M8 CONNECTOR

SISTEMA DI MONTAGGIO / SYSTEM OF ASSEMBLY

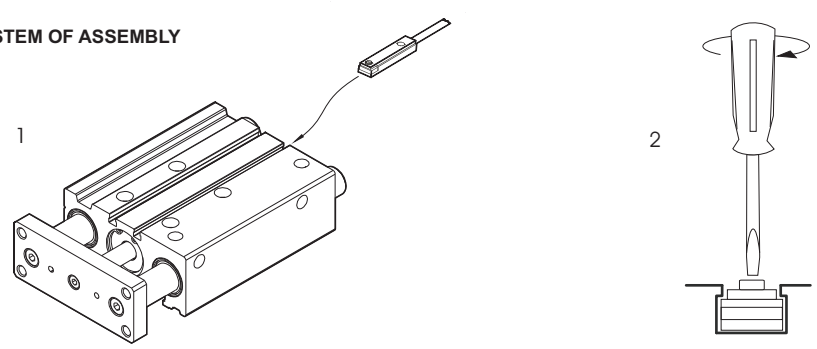



I Cilindri della serie CX sono stati realizzati rispettando la normativa DIN/ISO 15552. Tali cilindri sono particolarmente adatti in ambienti aggressivi, nell'industria navale, farmaceutica, alimentare. Gli alesaggi sono compresi tra 32 e 125.

Cylinders of series CX have been made respecting norm to DIN/ISO 15552. These cylinders are particularly suitable in aggressive atmospheres, in the naval and, alimentary industry. The bores are comprised from 32 to 125.

CHIAVE DI CODIFICA / KEY TO TYPE NUMBER

CX,00,1,000,0000

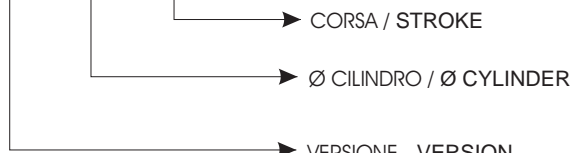

CORSA / STROKE

Ø CILINDRO / Ø CYLINDER

VERSIONE - VERSION

01 = DOPPIO EFFETTO-MAGNETICO / DOUBLE ACTING-MAGNETIC

03 = STELO PASSANTE - MAGNETICO / THROUGHROD - MAGNETIC

VERSIONE - VERSION

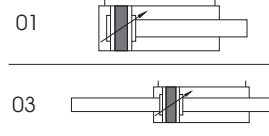

DATI TECNICI / TECHNICAL DATA

Alesaggi - Sizes	Ø32-40-50-63-80-100-125
Corse standard - Standard strokes	mm 25-50-80-100-125-160-200-250-320-350-400-500-600-700-800-900-1000
Fluido - Fluid	Aria con o senza lubrificazione - Lubricated or non lubricated air
Temperatura di esercizio - Operating temperature range	Poliuretano : -20C°+80C° / Viton: -10C°+150C°
Pressione massima di esercizio - Max operating pressure	10 bar
Forze sviluppate - Force	pag.datì tecnici / technical informations page
Consumo aria - Air consumption	pag.datì tecnici / technical informations page

COMPONENTI / COMPONENTS

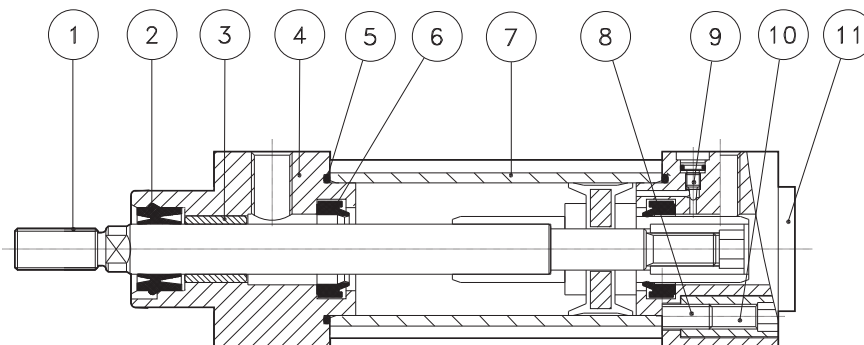

pos.	descrizione / description	materiale / material
1	stelo / rod	acciaio AISI 316 / stainless steel AISI 316
2	guarnizione stelo / rod seal	poliuretano / polyurethane
3	bussola guida / guide bush	bronzo sinterizzato / bronze syntherize
4	testata anteriore / front cap	acciaio AISI 304 / stainless steel AISI 304
5	o-ring	NBR
6	guarnizione ammortizzo / cushion seal	poliuretano / polyurethane
7	tubo / tube	acciaio AISI 304 / stainless steel AISI 304
8	tirante / connecting rod	acciaio AISI 316 / stainless steel AISI 316
9	vite reg. ammortizzo / regulator cushion screw	acciaio AISI 316 / stainless steel AISI 316
10	vite serraggio testata / fixing cap screw	acciaio AISI 316 / stainless steel AISI 316
11	testata posteriore / rear cap	acciaio AISI 304 / stainless steel AISI 304

DOPPIO EFFETTO
DOUBLE ACTING

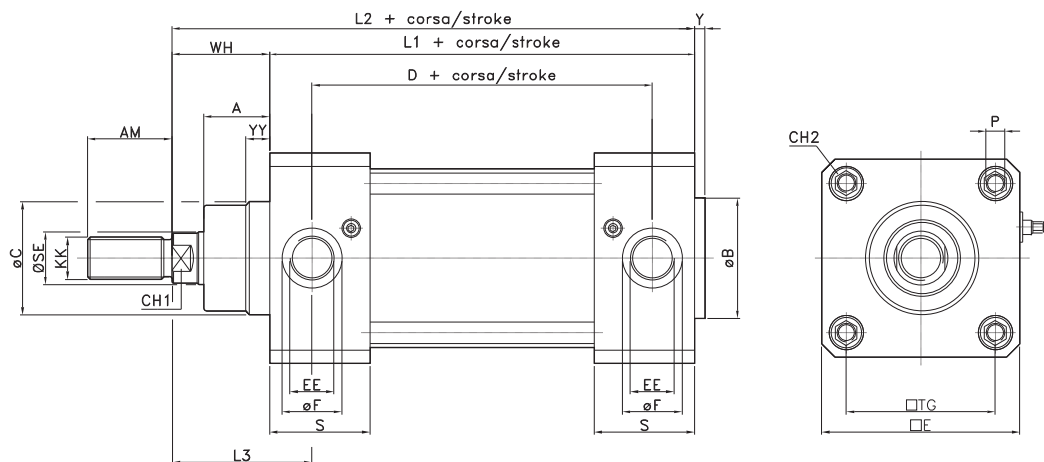
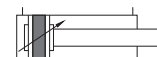

Ø	A	AM	B	C	D	E	EE	F	Y	YY	KK	L1	L2	L3	P	S	SE	TG	WH	Ch1	Ch2
32	18	22	30	30	67	50	G1/8"	16	4	9	M10x1.25	95	121	39.5	M6	30.8	12	32.5	26	10	6
40	22	24	35	35	77	55	G1/4"	19	4	9	M12x1.25	105	135	44	M6	33	16	38	30	13	6
50	25.5	32	40	40	78	65	G1/4"	19	4	9	M16x1.5	106	143	51	M8	33.7	20	46.5	37	16	8
63	25	32	45	45	89	75	G3/8"	22.7	4	9	M16x1.5	121	158	53	M8	38	20	56.5	37	16	8
80	35	40	45	45	96	95	G3/8"	22.7	4	9	M20x1.5	128	174	62	M10	40	25	72	46	21	10
100	38	40	55	55	102	110	G1/2"	28	4	9	M20x1.5	138	189	69	M10	43.5	25	89	51	21	10
125	46	54	60	60	124	139	G1/2"	28	6	10	M27x2	160	225	83	M12	53	32	110	65	27	12

STELO PASSANTE
THROUGH ROD

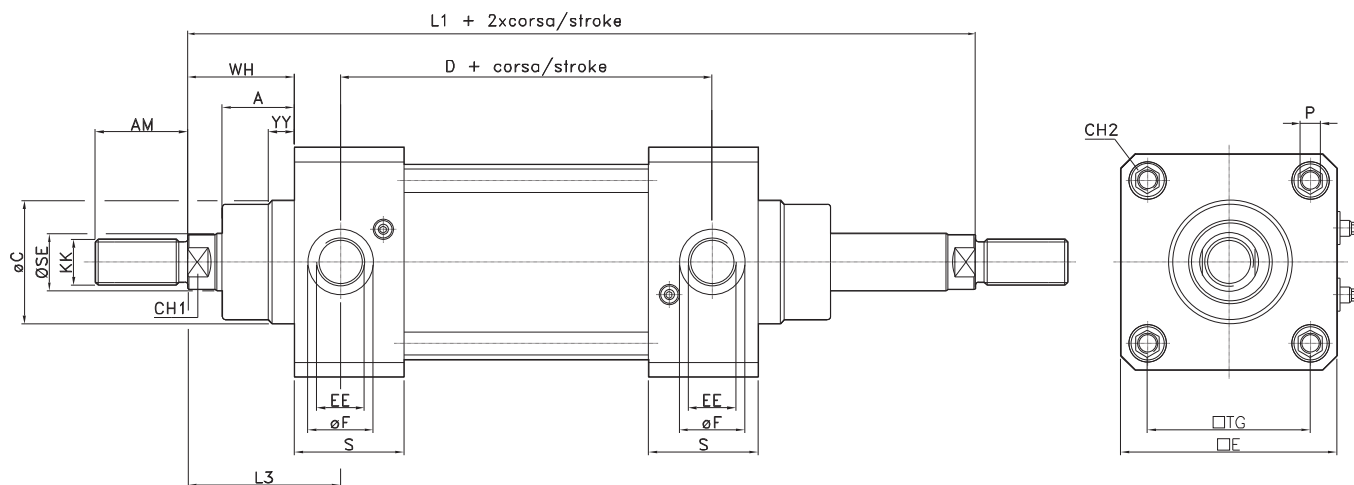
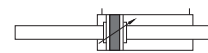

Ø	A	AM	C	D	E	EE	F	YY	KK	L1	L3	P	S	SE	TG	WH	Ch1	Ch2
32	18	22	30	67	50	G1/8"	16	9	M10x1.25	147	39.5	M6	30.8	12	32.5	26	10	6
40	22	24	35	77	55	G1/4"	19	9	M12x1.25	165	44	M6	33	16	38	30	13	6
50	25.5	32	40	78	65	G1/4"	19	9	M16x1.5	180	51	M8	33.7	20	46.5	37	16	8
63	25	32	45	89	75	G3/8"	22.7	9	M16x1.5	195	53	M8	38	20	56.5	37	16	8
80	35	40	45	96	95	G3/8"	22.7	9	M20x1.5	220	62	M10	40	25	72	46	21	10
100	38	40	55	102	110	G1/2"	28	9	M20x1.5	240	69	M10	43.5	25	89	51	21	10
125	46	54	60	124	139	G1/2"	28	11	M27x2	290	83	M12	53.2	32	110	65	28	12

Materiale: Inox AISI 316
Material: Stainless Steel AISI 316

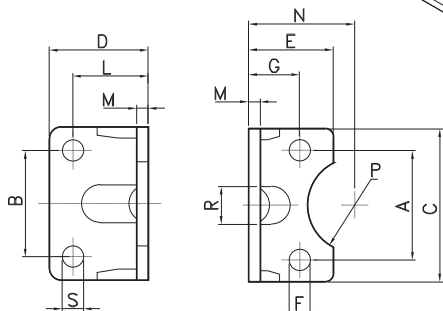
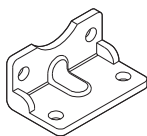

PIEDINO INOX / INOX PEDESTAL

CODE	Ø
AR4169032	32
AR4169040	40
AR4169050	50
AR4169063	63
AR4169080	80
AR4169100	100
AR4169125	125

Ø	A	B	C	D	E	F	G	L	M	N	P	R	S
32	32,5	32	45	35	30	7	15,75	24	4	32	15	11	7
40	38	36	52	36	30	7	17	28	4	36	17,5	15	9
50	46,5	45	65	47	36	9	21,75	32	5	45	20	16	9
63	56,5	50	75	45	35	9	21,75	32	5	50	22,5	18	9
80	72	63	95	55	47	11	27	41	6	63	22,5	17	12
100	89	75	115	57	53	11	26,5	41	6	71	27,5	24	14
125	110	90	140	70	70	14	35	45	8	90	30	-	16

Materiale: Inox AISI 316
Material: Stainless Steel AISI 316

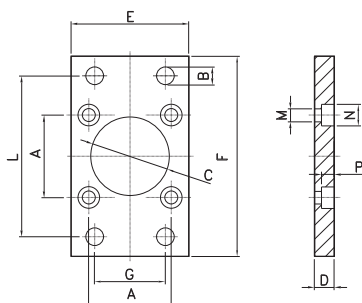
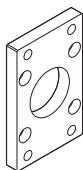

FLANGIA INOX / INOX FLANGE

CODE	Ø
AR4168032	32
AR4168040	40
AR4168050	50
AR4168063	63
AR4168080	80
AR4168100	100
AR4168125	125

Ø	A	B	C	D	E	F	G	L	M	N	P
32	32,5	7	30	10	45	80	32	64	6,5	10,5	6,5
40	38	9	35	10	52	90	36	72	6,5	10,5	6,5
50	46,5	9	40	12	65	110	45	90	8,5	13,5	8,5
63	56,5	9	45	12	75	120	50	100	8,5	13,5	8,5
80	72	12	45	16	95	150	63	126	10,5	16,5	10,5
100	89	14	55	16	115	170	75	150	10,5	16,5	10,5
125	110	16	60	20	140	205	90	180	13,5	20	12,5

Materiale: Inox AISI 316
Material: Stainless Steel AISI 316

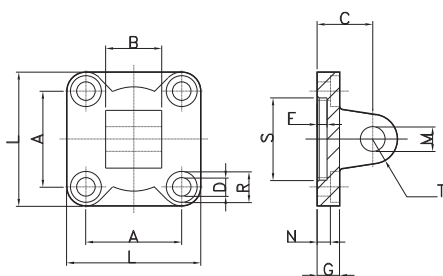
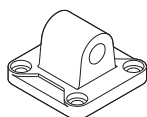

CERNIERA MASCHIO INOX / INOX MALE HINGE

CODE	Ø
AR4165032	32
AR4165040	40
AR4165050	50
AR4165063	63
AR4165080	80
AR4165100	100
AR4165125	125

Ø	A	B	C	D	F	G	L	M	N	R	S	T
32	32,5	26	22	6,6	5	9	45	10	5,5	11	30	10
40	38	28	25	6,6	5	9	52	12	5,5	11	35	12
50	46,5	32	27	9	5	11	65	12	6,5	15	40	12
63	56,5	40	32	9	5	11	75	16	6,5	15	45	16
80	72	50	36	11	5	14	95	16	10	18	45	16
100	89	60	41	11	5	14	115	20	10	18	55	20
125	110	70	50	14	7	20	140	25	10	20	60	25

Materiale: Inox AISI 316
Material: Stainless Steel AISI 316

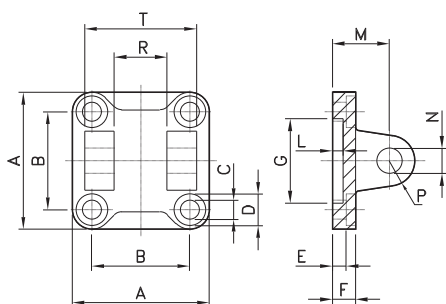
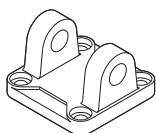

CERNIERA FEMMINA INOX / INOX FEMALE HINGE

CODE	Ø
AR4164032	32
AR4164040	40
AR4164050	50
AR4164063	63
AR4164080	80
AR4164100	100
AR4164125	125

Ø	A	B	C	D	E	F	G	L	M	N	P	R	T
32	45	32,5	6,6	11	5,5	9	30	5	22	10	10	26	45
40	52	38	6,6	11	5,5	9	35	5	25	12	12	28	52
50	65	46,5	9	15	6,5	11	40	5	27	12	12	32	60
63	75	56,5	9	15	6,5	11	45	5	32	16	16	40	70
80	95	72	11	18	10	14	45	5	36	16	16	50	90
100	115	89	11	18	10	14	55	5	41	20	20	60	110
125	140	110	14	20	10	20	60	7	50	25	25	70	130

Materiale: Inox AISI 316
Material: Stainless Steel AISI 316

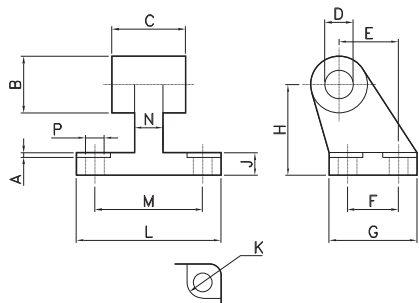
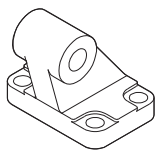

ARTICOLAZIONE A SQUADRA INOX

INOX SQUARE JOINT

CODE	Ø
AR4166032	32
AR4166040	40
AR4166050	50
AR4166063	63
AR4166080	80
AR4166100	100
AR4166125	125

Ø	A	B	C	D	E	F	G	H	J	K	L	M	N	P
32	1.6	20	26	10	21	18	31	32	8	11	51	38	10	6.6
40	1.6	22	28	12	24	22	35	36	10	11	54	41	15	6.6
50	1.6	26	32	12	33	30	45	45	12	15	65	50	16	9
63	1.6	30	40	16	37	35	50	50	14	15	67	52	16	9
80	2.5	30	50	16	47	40	60	63	14	18	86	66	20	11
100	2.5	38	60	20	55	50	70	71	17	18	96	76	20	11
125	3.2	45	70	25	70	60	90	90	20	20	124	94	30	14

Materiale: Inox AISI 316
Material: Stainless Steel AISI 316

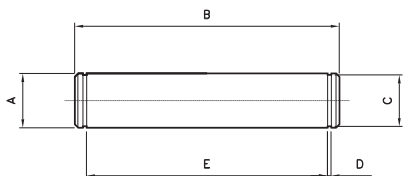
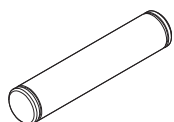

PERNO PER CERNIERA INOX

INOX PIVOT FOR HINGE

CODE	Ø
AR4167032	32
AR4167040	40
AR4167050	50
AR4167063	63
AR4167080	80
AR4167100	100
AR4167125	125

Ø	A	B	C	D	E
32	10	53	9.6	1.1	46
40	12	60	11.5	1.1	53
50	12	68	11.5	1.1	61
63	16	78	15.2	1.1	71
80	16	98	15.2	1.1	91
100	20	118	19	1.3	111
125	25	139	23.9	1.3	132

Materiale: Inox AISI 316
Material: Stainless Steel AISI 316

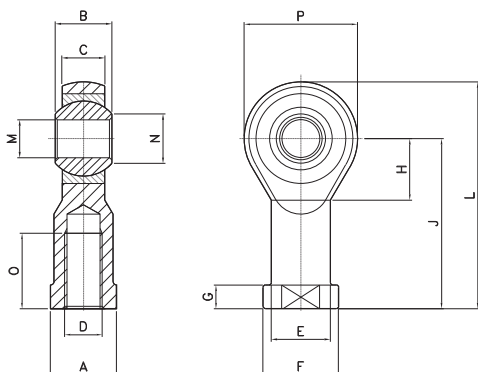

TESTA A SNODO INOX

INOX ROD ENDS

CODE	Ø
AR4187032	32
AR4187040	40
AR4187050	50-63
AR4187080	80-100
AR4187125	125

Ø	A	B	C	D	E	F	G	H	J	L	M	N	O	P
32	17	14	10.5	M10x1.25	15	19	6.5	15	43	57	10	12.9	20	28
40	19	16	12	M12x1.25	17.5	22	6.5	17	50	66	12	15.4	22	32
50-63	22	21	15	M16x1.5	22	27	8	23	64	85	16	19.3	28	42
80-100	30	25	18	M20x1.5	27.5	34	10	27	77	102	20	24.3	33	50
125	41	37	25	M27x2	40	50	15	36	110	145	30	34.8	51	70

Materiale: Inox AISI 316
Material: Stainless Steel AISI 316

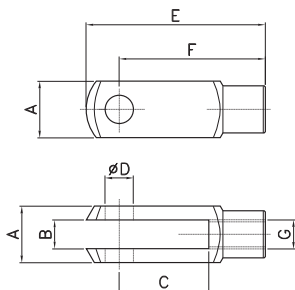
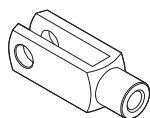

FORCELLA INOX
INOX YOKE

CODE	Ø
AR4218	32
AR4219	40
AR4220	50-63
AR4221	80-100
AR4222	125

Completo di perno e seeger / complete of pivot and seeger

Ø	A	B	C	D	E	F	G	Peso (g)
32	20	10	20	10	52	40	M10x1.25	72
40	24	12	24	12	62	48	M12x1.25	115
50-63	32	16	32	16	83	64	M16x1.5	270
80-100	40	20	40	20	105	80	M20x1.5	550
125	55	30	54	30	148	110	M27x2	1600

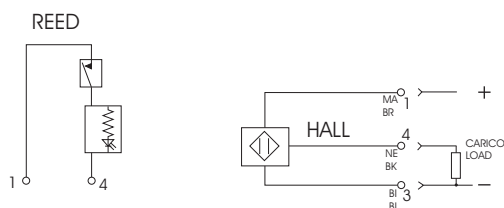
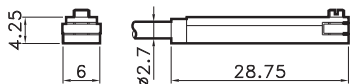
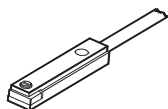

SENSORE A T
"T" SWITCH

CODE	
AR4023010	REED 2 FILI (MT.2,5) / REED WITH 2 WIRES (MT.2,5)
AR4023020	HALL 3 FILI (MT.2,5) / HALL WITH 3 WIRES (MT.2,5)
AR4023110	REED 2 FILI + M8 (CM 30) / REED WITH 2 WIRES WITH M8
AR4023120	HALL 3 FILI + M8 (CM 30) / HALL WITH 3 WIRES WITH M8

DATI TECNICI / TECHNICAL DATA

Grado di protezione / Protection class	IP 67 EN 60529
Temp. di impiego / Working temp.	-20°C +85°C
Materiale custodia / Housing material	PA
Tensione in DC / Tension in DC	Reed 3-30V / Hall 6-30V
Tensione in AC / Tension in AC	Reed 3-30V
Corrente a 25 C° / Current at 25 C°	Reed 0,20A / Hall 0,20A
Tempo inserzione / On time	Reed 0,5mS / Hall 0,8 uS
Tempo disinserione / Off time	Reed 0,1mS / Hall 0,3 uS

Materiale: Alluminio
Material: Aluminium

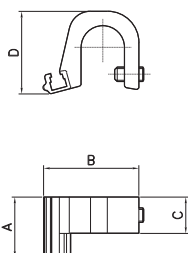
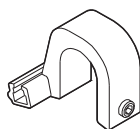

ADATTATORE SENSORE A "T"
ADAPTOR FOR "T" SWITCH

CODE	Ø
AR420032	32-40
AR420050	50-63
AR420080	80-100
AR4200125	125

Ø	A	B	C	D
32-40	25	30	15	20
50-63	25	35	15	26
80-100	25	38	15	30
125	25	40	15	35

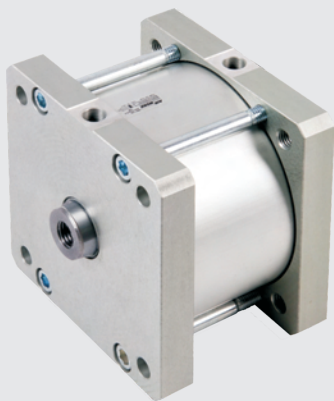

Airwork presenta i nuovi cilindri compatti di grandi dimensioni. In tutte le applicazioni ove sia necessario avere grande forza di spinta in ridotti spazi, il nuovo cilindro della serie CP, è la risposta giusta.

Airwork present the new compact cylinder of great dimensions. In all applications requiring great push force in small spaces, the new cylinder CP series is the correct answer.

CHIAVE DI CODIFICA / KEY TO TYPE NUMBER

CP 00 2 000 0000

→ CORSA / STROKE
→ Ø CILINDRO / Ø CYLINDER

→ VERSIONE - VERSION

- 01 = DOPPIO EFFETTO-MAGNETICO / DOUBLE ACTING-MAGNETIC
- 02 = DOPPIO EFFETTO-NON MAGNETICO / DOUBLE ACTING NON MAGNETIC
- 03 = STELO PASSANTE-MAGNETICO / THROUGH ROD-MAGNETIC
- 04 = STELO PASSANTE-NON MAGNETICO / THROUGH ROD-NON MAGNETIC

VERSIONE - VERSION

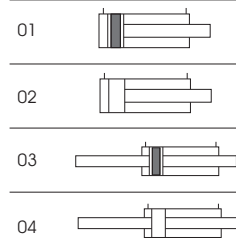

DATI TECNICI / TECHNICAL DATA

Alesaggi - Sizes	Ø 125 - 160 - 200
Corse standard - Standard strokes	mm 5-10-15-20-25-30-40-50-60-70-80-90-100-125-160-200-250
Fluido - Fluid	Aria con o senza lubrificazione - Lubricated or non lubricated air
Temperatura di esercizio - Operating temperature range	-20°C / +80°C
Pressione massima di esercizio - Max operating pressure	10 bar
Forze sviluppate - Force	pag.datì tecnici / technical informations page
Consumo aria - Air consumption	pag.datì tecnici / technical informations page

COMPONENTI / COMPONENTS

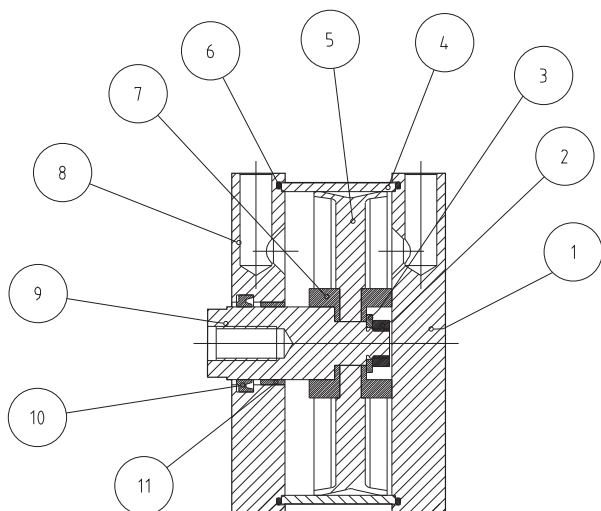

pos.	descrizione / description	materiale / material
1	testata posteriore / rear cap	alluminio / aluminium
2	dado fiss.pist / nut fixing piston	acciaio zincato / steel zinc plate
3	rondella / metal ring	acciaio zincato / steel zinc plate
4	tubo / tube	alluminio / aluminium
5	pistone / piston	NBR
6	o-ring	NBR
7	fine corsa / stop stroke ring	Delring
8	testata anteriore / front cap	alluminio / aluminium
9	stelo / rod	acciaio C40 cromato / steel C40 Chromed
10	guarnizione stelo / rod seal	poliuretano / polyurethane
11	bussola guida / guide bush	acciaio+PTFE / steel+PTFE

DOPPIO EFFETTO
DOUBLE ACTING

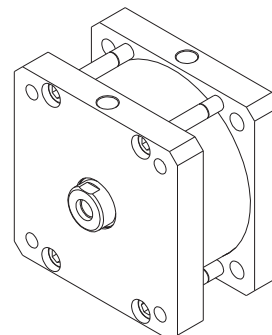
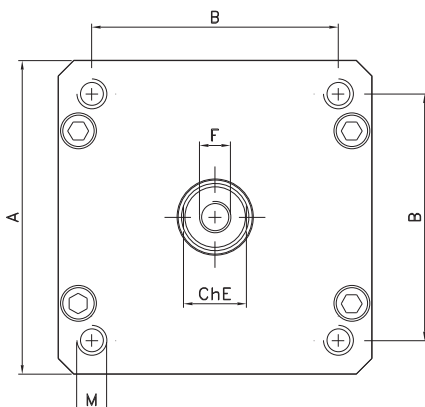
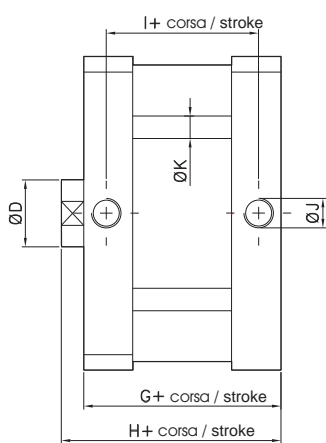
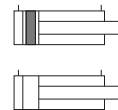

Ø	A	B	M	ØD	E	F	G	H	I	J	ØK
125	140	110	M12	30	28	M14x25 uf.	78	88	58	G1/4"	10
160	180	140	M16	40	36	M20x30 uf.	87	99	63	G3/8"	12
200	220	175	M16	40	36	M20x30 uf.	87	99	63	G3/8"	14

STELO PASSANTE
THROUGH ROD

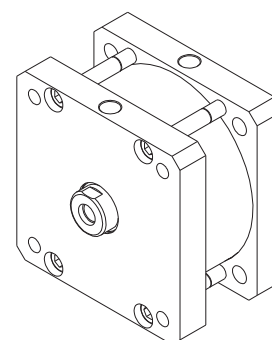
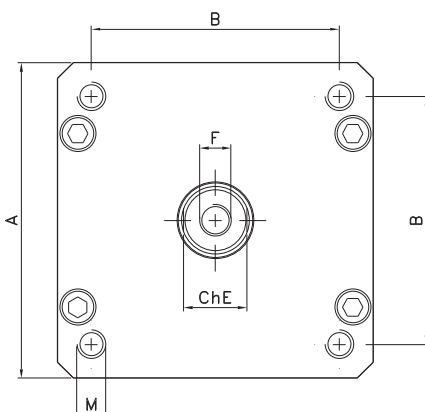
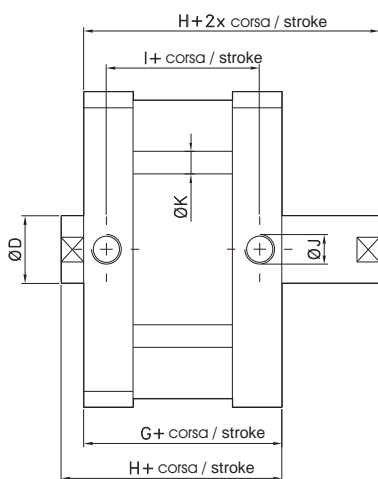
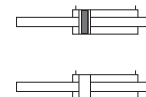

Ø	A	B	M	ØD	E	F	G	H	I	J	ØK
125	140	110	M12	30	28	M14x25 uf.	78	88	58	G1/4"	10
160	180	140	M16	40	36	M20x30 uf.	87	99	63	G3/8"	12
200	220	175	M16	40	36	M20x30 uf.	87	99	75	G3/8"	14

Materiale: Acciaio
Material: Steel

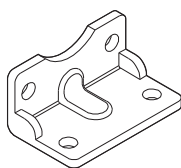

PIEDINO / PEDESTAL

CODE	Ø
AR4152125	125
AR4152160	160
AR4152200	200

con viti di fissaggio, aggiungere "V"
esempio: AR4152125V

with screws for fixing, to add "V"
example: AR4152125V

Materiale: Acciaio
Material: Steel

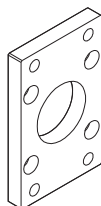

FLANGIA / FLANGE

CODE	Ø
AR4151125	125
AR4151160	160
AR4151200	200

con viti di fissaggio, aggiungere "V"
esempio: AR4151125V

with screws for fixing, to add "V"
example: AR4151125V

Materiale: Alluminio
Material: Aluminium

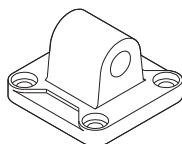

CERNIERA MASCHIO / MALE HINGE

CODE	Ø
AR4149125	125
AR4149160	160
AR4149200	200

con viti di fissaggio, aggiungere "V"
esempio: AR4149125V

with screws for fixing, to add "V"
example: AR4149125V

Materiale: Alluminio
Material: Aluminium

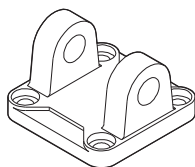

CERNIERA FEMMINA / FEMALE HINGE

CODE	Ø
AR4147125	125
AR4147160	160
AR4147200	200

con viti di fissaggio, aggiungere "V"
esempio: AR4147125V

with screws for fixing, to add "V"
example: AR4147125V

Materiale: Alluminio
Material: Aluminium

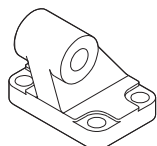

ARTICOLAZIONE A SQUADRA
SQUARE JOINT

CODE	Ø
AR4156125	125
AR4156160	160
AR4156200	200

con viti di fissaggio, aggiungere "V"
esempio: AR4156125V

with screws for fixing, to add "V"
example: AR4156125V

Materiale: Acciaio
Material: Steel

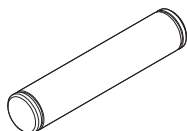

PERNO PER CERNIERA / PIVOT FOR HINGE

CODE	Ø
AR4150125	125
AR4150160	160
AR4150200	200

completa di n° 2 seeger
complete of n° 2 seegers

Materiale: Acciaio
Material: Steel

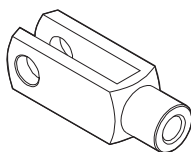

FORCELLA

YOKE

CODE Ø

AR40678	125	completo di perno / complete of pivot
AR40679	160-200	completo di perno / complete of pivot

Materiale: Acciaio
Material: Steel

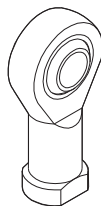

TESTA A SNODO

ROD ENDS

CODE Ø

AR40667	125
AR40669	160-200

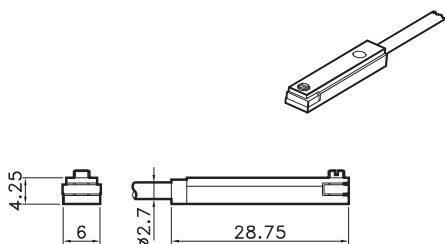

SENSORE A T
"T" SWITCH

CODE

AR4023010	REED 2 FILI (MT.2,5) / REED WITH 2 WIRES (MT.2,5)
AR4023020	HALL 3 FILI (MT.2,5) / HALL WITH 3 WIRES (MT.2,5)
AR4023110	REED 2 FILI + M8 (CM 30) / REED WITH 2 WIRES WITH M8
AR4023120	HALL 3 FILI + M8 (CM 30) / HALL WITH 3 WIRES WITH M8

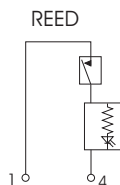

HALL

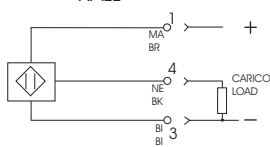

DATI TECNICI / TECHNICAL DATA

Grado di protezione / Protection class	IP 67 EN 60529
Temper. Di impiego / Working temp.	-20C° +85C°
Materiale custodia / Housing material	PA
Tensione in DC / Tension in DC	Reed 3-30V / Hall 6-30V
Tensione in AC / Tension in AC	Reed 3-30V
Corrente a 25 C° / Current at 25 C°	Reed 0,20A / Hall 0,20A
Tempo inserzione / On time	Reed 0,5mS / Hall 0,8 uS
Tempo disinserzione / Off time	Reed 0,1mS / Hall 0,3 uS

Materiale: Alluminio
Material: Aluminium

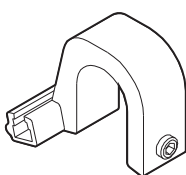

ADATTATORE SENSORE A "T"
ADAPTOR FOR "T" SWITCH

CODE Ø

AR4200125	125-160-200
-----------	-------------

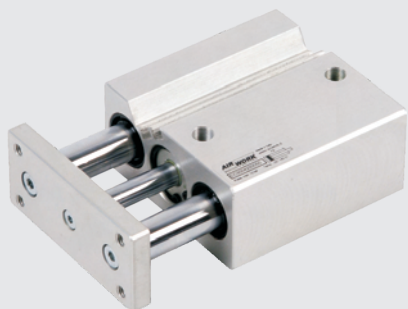

Il nuovissimo cilindro compatto guidato prodotto da AIRWORK, è un attuatore lineare con caratteristiche di grande robustezza e minimi ingombri, infatti è dotato di un cilindro pneumatico centrale con un sistema di guida con aste di grande diametro che scorrono su bronzine autolubrificanti oppure su manicotti a ricircolo di sfere. Inoltre è possibile montare sensori magnetici a scomparsa.

Airwork is proud to announce the last birth: the new guided compact cylinder. It is a linear actuator with very high robustness and very low dimension. It has a central pneumatic cylinder while the guide system is based on very big diameter rods, moving on self lubricant brass bearings or balls sleeves. Moreover it is possible to mount disappearing magnetic sensors.

CHIAVE DI CODIFICA / KEY TO TYPE NUMBER

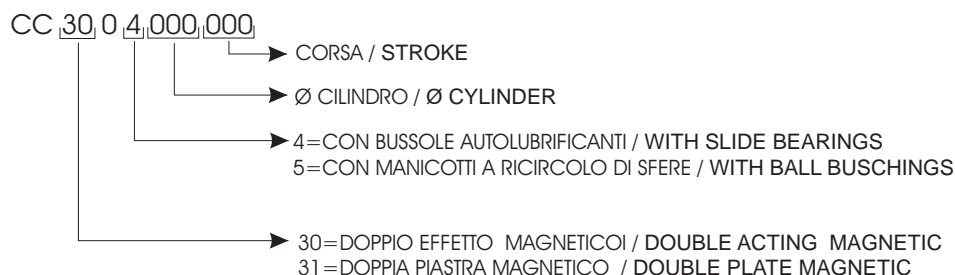

CORSE STANDARD - STANDARD STROKES

Ø16	mm 10-20-30-40-50
Ø20	mm 20-30-40-50-75-100
Ø25	mm 20-30-40-50-75-100
Ø32	mm 25-50-75-100
Ø40	mm 25-50-75-100
Ø50	mm 25-50-75-100

CORSE INTERMEDIE / INTERMEDIATE STROKES

è possibile ottenere qualsiasi tipo di corsa da 1 a 100 mm.

Le dimensioni del cilindro saranno quelle della corsa standard immediatamente successiva. Esempio: Ø cilindro 32 corsa 45mm, avrà le dimensioni della corsa 50mm, e il codice di ordinazione sarà: CC3004.32.045.

It's possible to obtain any type of stroke from 1 to 100mm.

The dimensions of the cylinder will be those of the immediately following standard stroke.

Example: a cylinder Ø32 stroke 45mm will have the dimensions of stroke 50mm and its order code will be CC3004.32.045.

DATI TECNICI / TECHNICAL DATA

Fluido - Fluid	Aria con o senza lubrificazione - Lubricated or non lubricated air
Temperatura di esercizio - Operating temperature range	-20C° / +80C°
Pressione massima di esercizio - Max operating pressure	10 bar
Forze sviluppate - Force	pag.dati tecnici / technical informations page
Consumo aria - Air consumption	pag.dati tecnici / technical informations page

COMPONENTI / COMPONENTS

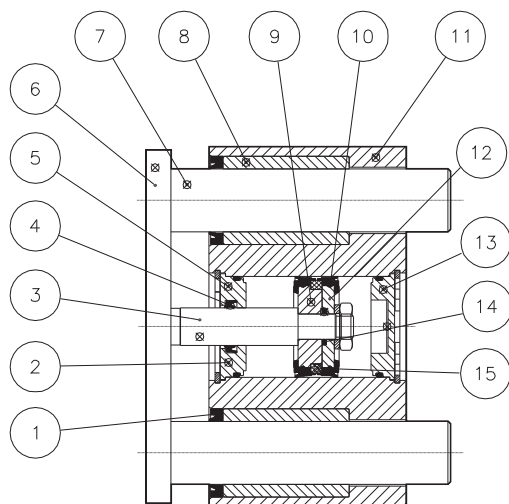

pos.	descrizione / description	materiale / material
1	guarniz.tergiasta / wiperod seal	NBR
2	o-ring	NBR
3	stelo / rod	acciaio C40 cromato / steel C40 chromed
4	guarnizione stelo / rod seal	poliuretano / polyurethane
5	testata anteriore / front cap	alluminio / aluminium
6	piastra / plate	alluminio / aluminium
7	stelo guida / guide rod	acciaio C40 cromato / steel C40 chromed acciaio C40 temprato / steel C40 tempered
8	bussole / slide bearing manicotti a sfera / ball busching	bronzo / bronze acciaio / steel
9	semipistone / semipiston	alluminio / aluminium
10	guarnizione pist. / seal piston	poliuretano / polyurethane
11	corpo cilindro / body cylinder	alluminio / aluminium
12	semipistone / semipiston	alluminio / aluminium
13	testata posteriore / rear cap	alluminio / aluminium
14	o-ring	NBR
15	magnete / magnet	plastroferrite

CARICHI LATERALI AMMISSIBILI CON BUSSOLE AUTOLUBRIFICANTI
LATERAL LOADS ADMISSED WITH SLIDE BEARINGS

CARICHI LATERALI AMMISSIBILI CON MANICOTTI A RICIRCOLO DI SFERE
LATERAL LOADS ADMISSED WITH BALL BUSHINGS

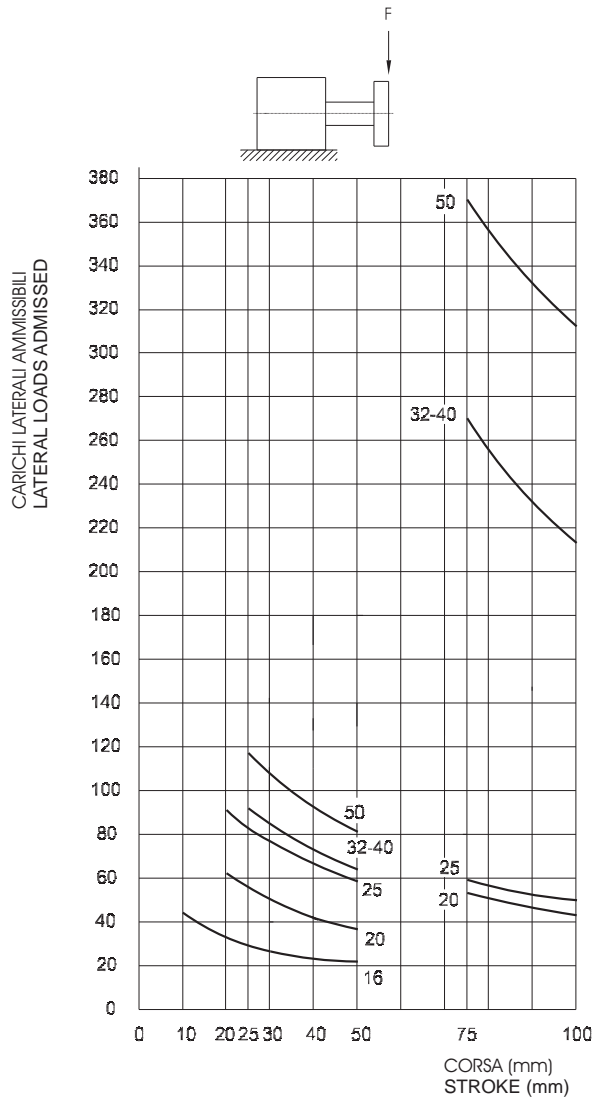
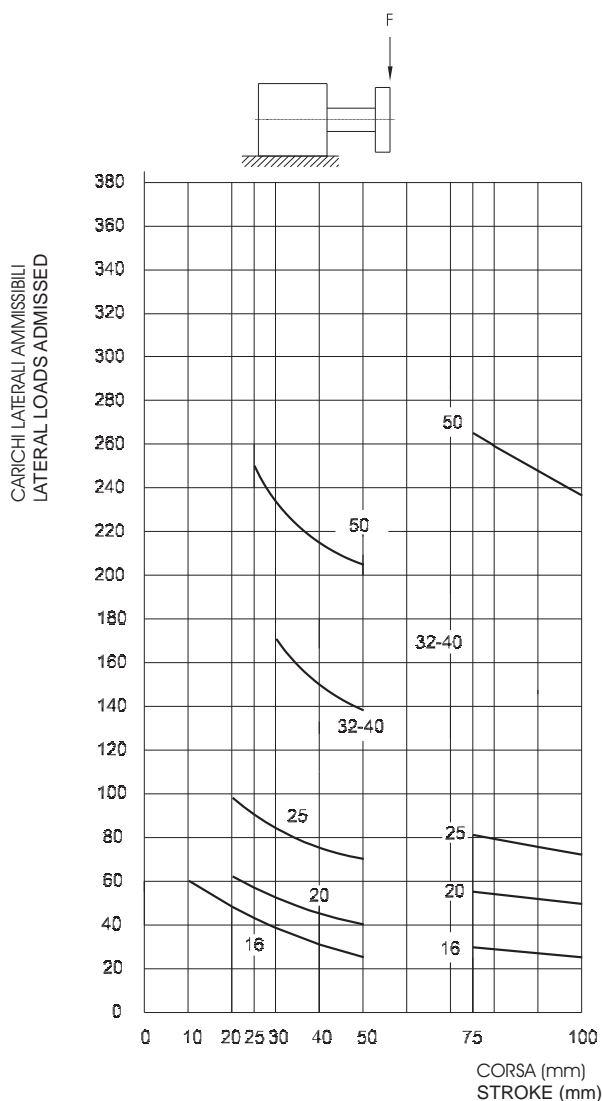

Ø mm	CARICO (N)								
16	80	48		40	30	25			
20		62		52	45	40	55	49	
25			96	84	75	70	81	67	
32				170			138	166	148
40				170			138	166	148
50				250			205	265	236
CORSE →	10	20	25	30	40	50	75	100	

Ø mm	CARICO (N)								
16	44	34		27	23	21			
20		62		50	42	36	53	42	
25			94	79	68	60	59	50	
32				84			58	270	213
40				92			64	270	213
50				117			81	370	312
CORSE →	10	20	25	30	40	50	75	100	

MOMENTO TORCENTE / TORQUE

T (N/m)

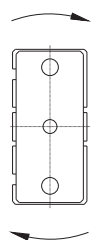

CON BUSSOLE AUTOLUBRIFICANTI
WITH SLIDE BEARINGS

Ø mm	MOMENTO (Nm)								
16	0.69	0.58		0.49	0.43	0.38			
20		1.05		0.93	0.83	0.75	1.88	1.63	
25			1.98	1.67	1.46	1.28	2.8	2.50	
32				5.13			4.19	4.97	4.36
40				5.13			4.19	4.97	4.36
50				8.00			5.80	7.00	6.72
CORSE →	10	20	25	30	40	50	75	100	

CON MANICOTTI A RICIRCOLO DI SFERE
WITH BALL BUSHINGS

Ø mm	MOMENTO (Nm)								
16	0.83	0.65		0.52	0.44	0.40			
20		1.20		0.96	0.81	0.69	1.02	0.93	
25			2.00	1.69	1.45	1.28	1.26	1.09	
32				2.04			1.41	6.58	5.19
40				2.47			1.72	7.25	5.72
50				3.22			2.22	10.17	8.58
CORSE →	10	20	25	30	40	50	75	100	

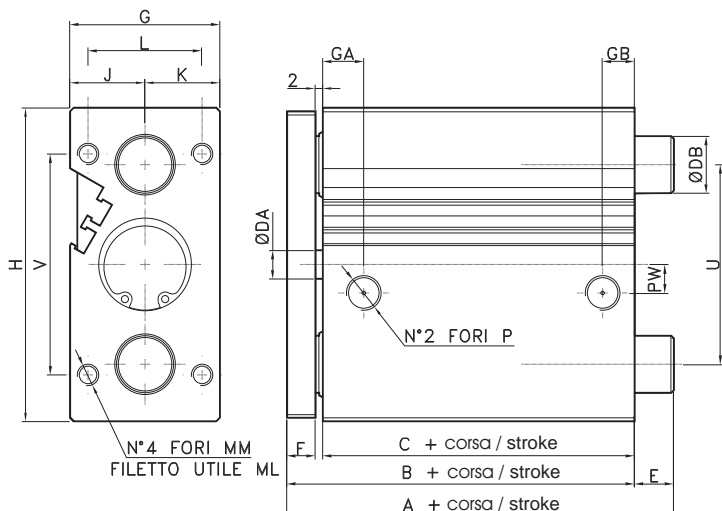

DOPPIO EFFETTO
DOUBLE ACTING

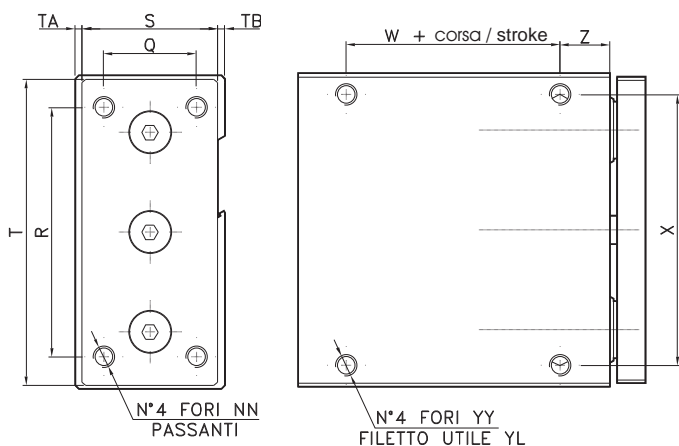
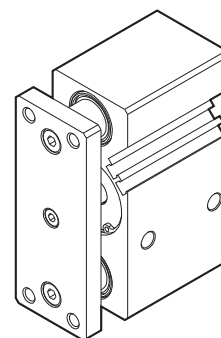

+ = aggiungere la corsa / add the stroke
++ = aggiungere la corsa x 2 / add the stroke x 2

Ø	B	C	DA	DB	F	G	GA	GB	H	J	K	L	MM	ML	NN	P	PW	Q	R	S	T	TA	TB	U	V	W	X	YY	YL	Z
16	44	33	8	10	9	33	11	8	64	18	15	22	M5	13	M5	M5	5.5	16	52	25	62	2.5	5.5	38	4.2	7	54	M5	8	13
20	48	37	10	12	9	36	10.5	8.5	74	19	17	26	M5	13	M5	G1/8	7	18	60	30	72	2	4	4.6	5.2	10	64	M5	8	13
25	48.5	37.5	10	16	9	4.2	11.5	9	88	21	21	32	M6	15	M6	G1/8	8	26	70	38	86	2	2	5.6	6.2	10	76	M6	9	14
32	49.5	37.5	12	20	10	5.1	12.5	9	114	25	26	38	M8	20	M8	G1/8	15	30	96	4.8	112	2	1	8.0	8.0	5	100	M8	11	16
40	56	44	12	20	10	5.1	14	10	124	25	26	38	M8	20	M8	G1/8	21	30	106	4.8	122	2	1	9.0	9.0	10	110	M8	11	17
50	58	44	16	25	12	5.9	14	11	140	29	30	44	M10	25	M10	G1/4	27	40	120	5.6	138	2	1	10.0	10.0	10	124	M10	12.5	17

BUSSOLE SINTERIZZATE SLIDE BEARINGS					
Ø	quota A (CORSE)		quota E (CORSE)		DB
16	4.4 (10-50)	-- (75-100)	0 (10-50)	-- (75-100)	10
20	4.8 (20-50)	6.7 (75-100)	0 (20-50)	1.9 (75-100)	12
25	4.8.5 (20-50)	7.7 (75-100)	0 (20-50)	2.8.5 (75-100)	16
32	7.3.5 (25-50)	9.9.5 (75-100)	2.4 (25-50)	5.0 (75-100)	20
40	7.3.5 (25-50)	9.9.5 (75-100)	1.7.5 (25-50)	4.3.5 (75-100)	20
50	8.3 (25-50)	10.0 (75-100)	2.5 (25-50)	4.2 (75-100)	25

MANICOTTI A RICIRCOLO DI SFERE BALL BUSCHINGS							
Ø	quota A (CORSE)			quota E (CORSE)		DB	
16	4.4 (10-30)	6.7 (40-50)	0 (10-30)	2.3 (40-50)		10	
20	4.8 (20-30)	7.3 (40-100)	0 (20-30)	2.5 (40-100)		12	
25	4.8.5 (20-30)	8.0.5 (40-100)	0 (20-30)	3.2 (40-100)		16	
32	5.6 (25)	7.7 (50)	9.9.5 (75-100)	6.5 (25)	2.7.5 (50)	5.0 (75-100)	20
40	5.6 (25)	7.7 (50)	9.9.5 (75-100)	0 (25)	2.1 (50)	4.3.5 (75-100)	20
50	6.3 (25)	10.0 (50)	10.4 (75-100)	5 (25)	4.2 (50)	4.6 (75-100)	25

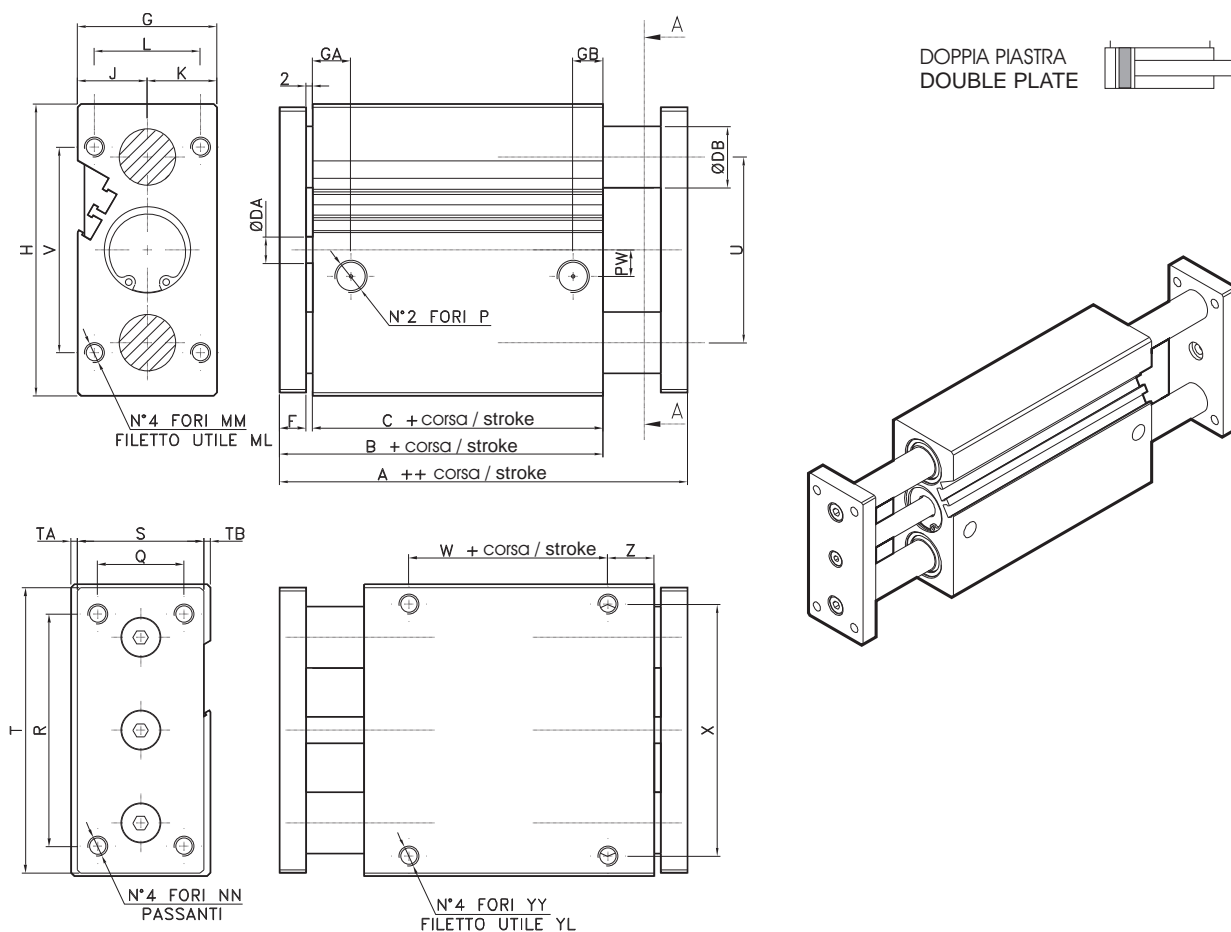

+ = aggiungere la corsa / add the stroke
++ = aggiungere la corsa x 2 / add the stroke x 2

Ø	A	B	C	DA	DB	F	G	GA	GB	H	J	K	L	MM	ML	NN	P	PW	Q	R	S	T	TA	TB	U	V	W	X	YY	YL	Z
16	55	44	33	8	10	9	33	11	8	64	18	15	22	M5	13	M5	M5	5.5	16	52	25	62	2.5	5.5	38	4.2	7	54	M5	8	13
20	59	48	37	10	12	9	36	10.5	8.5	74	19	17	26	M5	13	M5	G1/8	7	18	60	30	72	2	4	4.6	52	10	64	M5	8	13
25	59.5	48.5	37.5	10	16	9	42	11.5	9	88	21	21	32	M6	15	M6	G1/8	8	26	70	38	86	2	2	5.6	62	10	76	M6	9	14
32	61.5	49.5	37.5	12	20	10	51	12.5	9	114	25	26	38	M8	20	M8	G1/8	15	30	96	4.8	112	2	1	8.0	80	5	100	M8	11	16
40	68	56	44	12	20	10	51	14	10	124	25	26	38	M8	20	M8	G1/8	21	30	106	4.8	122	2	1	9.0	90	10	110	M8	11	17
50	72	58	44	16	25	12	59	14	11	140	29	30	44	M10	25	M10	G1/4	27	4.0	120	5.6	138	2	1	10.0	100	10	124	M10	12.5	17

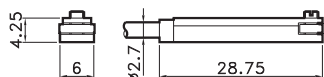
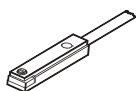

SENSORE A T / "T" SWITCH
CODE

AR4023010	REED 2 FILI (MT.2,5) / REED WITH 2 WIRES (MT.2,5)
AR4023020	HALL 3 FILI (MT.2,5) / HALL WITH 3 WIRES (MT.2,5)
AR4023110	REED 2 FILI + M8 (CM 30) / REED WITH 2 WIRES WITH M8
AR4023120	HALL 3 FILI + M8 (CM 30) / HALL WITH 3 WIRES WITH M8

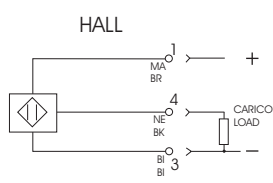
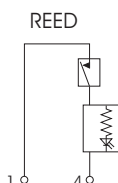

DATI TECNICI / TECHNICAL DATA

Grado di protezione / Protection class	IP 67 EN 60529
Temp. di impiego / Working temp.	-20C° +85C°
Materiale custodia / Housing material	PA
Tensione in DC / Tension in DC	Reed 3-30V / Hall 6-30V
Tensione in AC / Tension in AC	Reed 3-30V
Corrente a 25 C° / Current at 25 C°	Reed 0,20A / Hall 0,20A
Tempo inserzione / On time	Reed 0,5mS / Hall 0,8 uS
Tempo disinserione / Off time	Reed 0,1mS / Hall 0,3 uS



Il nuovissimo cilindro compatto guidato prodotto da AIRWORK, è un attuatorè lineare con caratteristiche di grande robustezza e minimi ingombri, infatti è dotato di un cilindro pneumatico centrale con un sistema di guida con aste di grande diametro che scorrono su bronzine autolubrificanti oppure su manicotti a ricircolo di sfere. E' possibile montare il cilindro in varie posizioni e cambiare l'orientamento delle alimentazioni a seconda delle necessità. Inoltre è possibile montare sensori magnetici a scomparsa.

Guided compact cylinders are Airwork's top of the range. This linear actuator offers a very high robustness combined with very small dimension. It has a central pneumatic cylinder and the guiding system is based on rods with very big diameter which move on self lubricant brass bearings or balls sleeves. It is possible to mount the cylinder in different positions and to change the orientation of the feeding devices, following to different needs. Moreover it is possible to mount magnetic sensors.

CHIAVE DI CODIFICA / KEY TO TYPE NUMBER

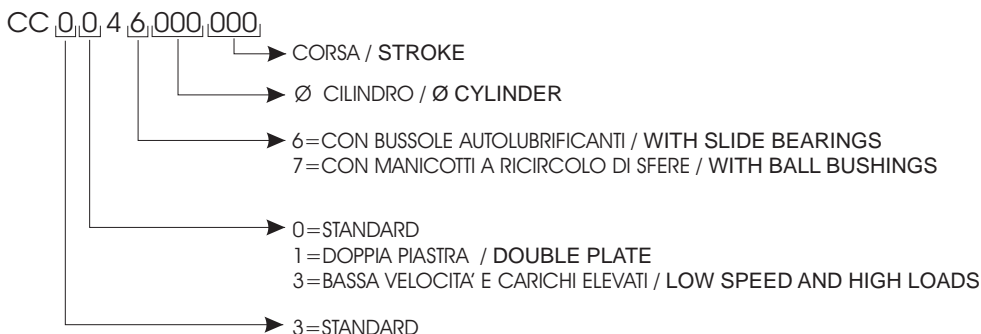

CORSE STANDARD - STANDARD STROKES

Ø16	mm 10-20-30-40-50-75-100-125-150-175-200
Ø20	mm 20-30-40-50-75-100-125-150-175-200-250-300-350-400
Ø25	mm 20-25-30-40-50-75-100-125-150-175-200-250-300-350-400
Ø32	mm 25-50-75-100-125-150-175-200-250-300-350-400
Ø40	mm 25-50-75-100-125-150-175-200-250-300-350-400
Ø50	mm 25-50-75-100-125-150-175-200-250-300-350-400
Ø63	mm 25-50-75-100-125-150-175-200-250-300-350-400

CORSE INTERMEDIE / INTERMEDIATE STROKES

È possibile ottenere qualsiasi tipo di corsa da 1 a 400 mm. Le dimensioni del cilindro saranno quelle della corsa standard immediatamente successiva. Esempio: Ø cilindro 32 corsa 45mm, avra le dimensioni della corsa 50mm, è il codice di ordinazione sarà: CC3046.32.045.

It's possible to have any length of stroke from 1 to 400mm. The dimensions of the cylinder will be those of the nearest following standard stroke. Example: a cylinder Ø32with stroke 45mm will have the dimensions of the 50mm stroke and its order code will be CC3046320045.

DATI TECNICI / TECHNICAL DATA

Fluido - Fluid	Aria con o senza lubrificazione - Lubricated or non lubricated air
Temperatura di esercizio - Operating temperature range	-20C° / +80C°
Pressione massima di esercizio - Max operating pressure	10 bar
Forze sviluppate - Force	pag.dati tecnici / technical informations page
Consumo aria - Air consumption	pag.dati tecnici / technical informations page

SISTEMA DI MONTAGGIO / SYSTEM OF ASSEMBLY

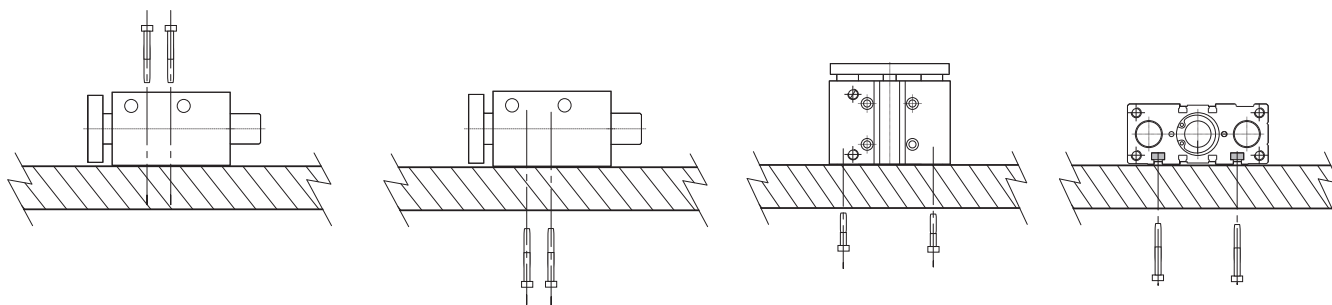

COMPONENTI / COMPONENTS

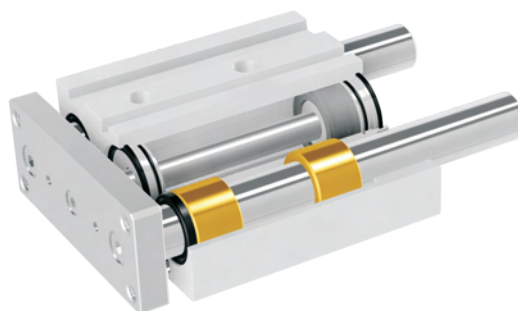
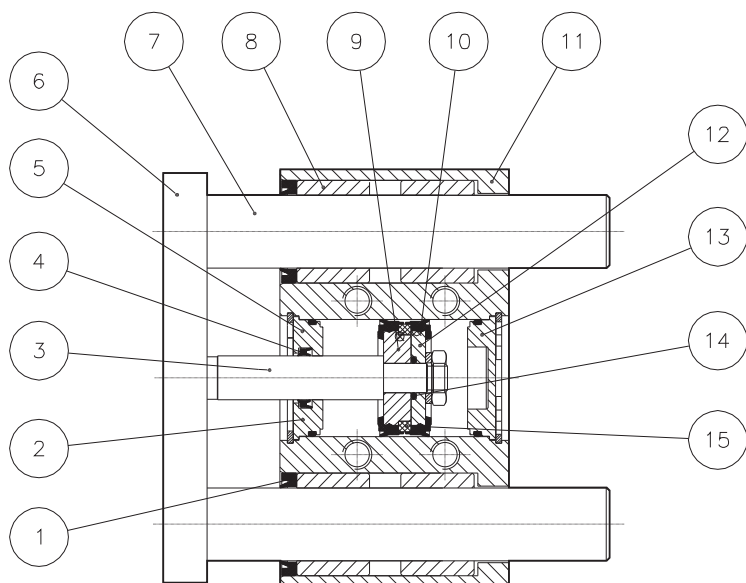

pos.	descrizione / description	materiale / material
1	guarniz. tergiasia / wiperod seal	NBR
2	o-ring	NBR
3	stelo / rod	acciaio C40 cromato / steel C40 chromed
4	guarnizione stelo / rod seal	poliuretano / polyurethane
5	testata anteriore / front cap	alluminio / aluminium
6	piastra / plate	acciaio nichelato / nickered steel
7	stelo guida / guide rod	acciaio C40 cromato / steel C40 chromed
8	bussole / slide bearing	bronzo / bronze
9	semipistone / semipiston	alluminio / aluminium
10	guarnizione pist. / seal piston	poliuretano / polyurethane
11	corpo cilindro / body cylinder	alluminio / aluminium
12	semipistone / semipiston	alluminio / aluminium
13	testata posteriore / rear cap	alluminio / aluminium
14	o-ring	NBR
15	magnete / magnet	plastoferrite

Tutti gli alesaggi e tutte le corse, hanno n°4
bussole in bronzo
All sizes and all strokes, have n°4 slide bearing

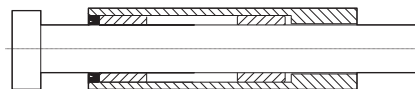
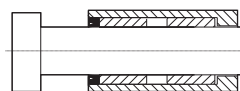

KIT GUARNIZIONI / SEALS KIT

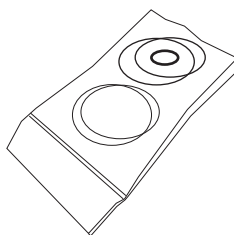
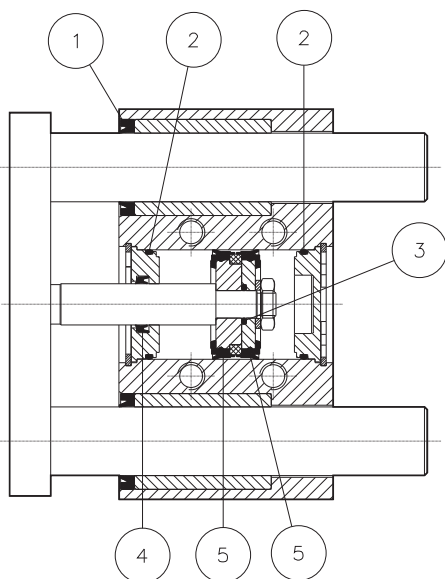

KIT GUARNIZIONI PER VERSIONE BUSSOLE IN BRONZO
SEALS KIT FOR SLIDE BEARINGS VERSION

CODE	Ø
KZ061016	16
KZ061020	20
KZ061025	25
KZ061032	32
KZ061040	40
KZ061050	50
KZ061063	63

KIT GUARNIZIONI PER VERSIONE MANICOTTI A SFERA
SEALS KIT FOR BALL BUSHINGS VERSION

CODE	Ø
KZ071016	16
KZ071020	20
KZ071025	25
KZ071032	32
KZ071040	40
KZ071050	50
KZ071063	63

Il kit comprende le guarnizioni segnalate con i numeri che vanno da 1 a 5.
The kit includes seals indicated with numbers from 1 to 5.

VERSIONI SPECIALI / SPECIAL VERSIONS

CON RASCHIASTELI IN METALLO / WITH METAL SCRAPERS

CODE: CC3066.Ø.corsa/stroke

Per le dimensioni di questa versione, contattare il nostro ufficio commerciale.
For dimensions of this version, please contact our sales department.

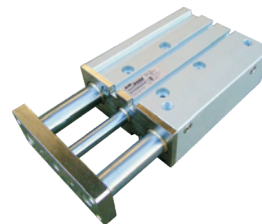

CON RASCHIASTELI RINFORZATI / WITH REINFORCED SCRAPERS

CODE: CC3086.Ø.corsa/stroke

Per le dimensioni di questa versione, contattare il nostro ufficio commerciale.
For dimensions of this version, please contact our sales department.



PER BASSA VELOCITA' CON CARICHI ELEVATI / FOR LOW SPEED AND HIGH LOADS

CODE: CC3346.Ø.corsa/stroke

Per le dimensioni di questa versione, contattare il nostro ufficio commerciale.
For dimensions of this version, please contact our sales department.

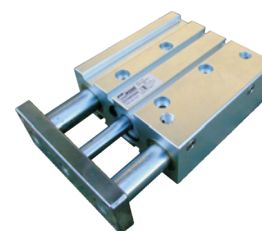

PER ALTA TEMPERATURA / FOR HIGH TEMPERATURE

CODE: CC3036.Ø.corsa/stroke

Per le dimensioni di questa versione, contattare il nostro ufficio commerciale.
For dimensions of this version, please contact our sales department.



CON CORSA REGOLABILE / WITH ADJUSTABLE STROKE

CODE: CC3446.Ø.corsa/stroke

Per le dimensioni di questa versione, contattare il nostro ufficio commerciale.
For dimensions of this version, please contact our sales department.

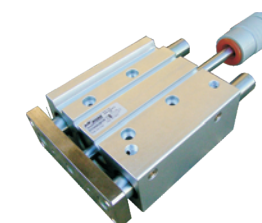

CON STELI, PIASTRA E VITI IN ACCIAIO INOX / WITH RODS, PLATE AND SCREWS IN STAINLESS STEEL

CODE: CC6046.Ø.corsa/stroke

Per le dimensioni di questa versione, contattare il nostro ufficio commerciale.
For dimensions of this version, please contact our sales department.



CARICHI AMMISSIBILI CON BUSSOLE IN BRONZO / LOADS ADMISSED WITH SLIDE BEARINGS

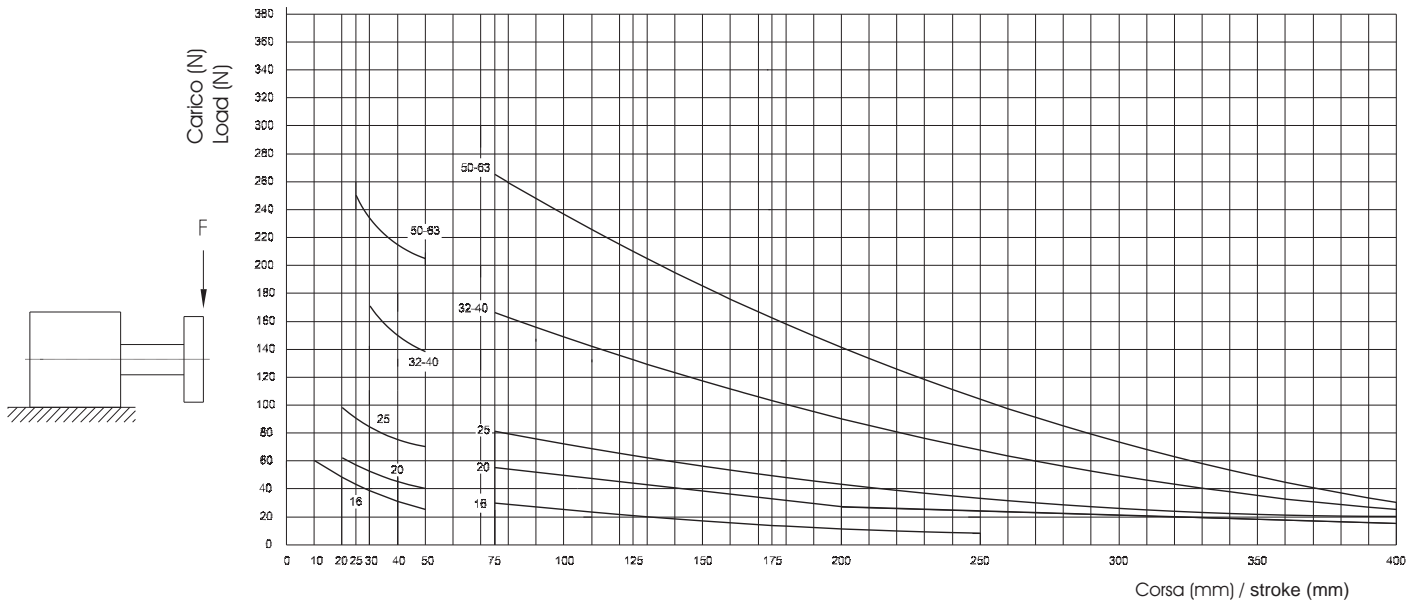

Ø mm	CARICO (N)															
16	60	48		40	30	25	30	24	20.5	17	13.5	11	8			
20		62		52	45	40	55	49	44	38	32.5	27	24	21	18	
25			98	84	75	70	81	67	60	54	48	43	34	27	23	
32				170			138	166	148	132	117	103	90	67	49	
40					170		138	166	148	132	117	103	90	67	49	
50						250	205	265	236	208	184	182	141	104	73	
63							250	265	236	208	184	182	141	104	73	
CORSE →	10	20	25	30	40	50	75	100	125	150	175	200	250	300	350	400

CARICHI AMMISSIBILI CON MANICOTTI A RICIRCOLO DI SFERE / LOADS ADMISSED WITH BALL BUSCHING

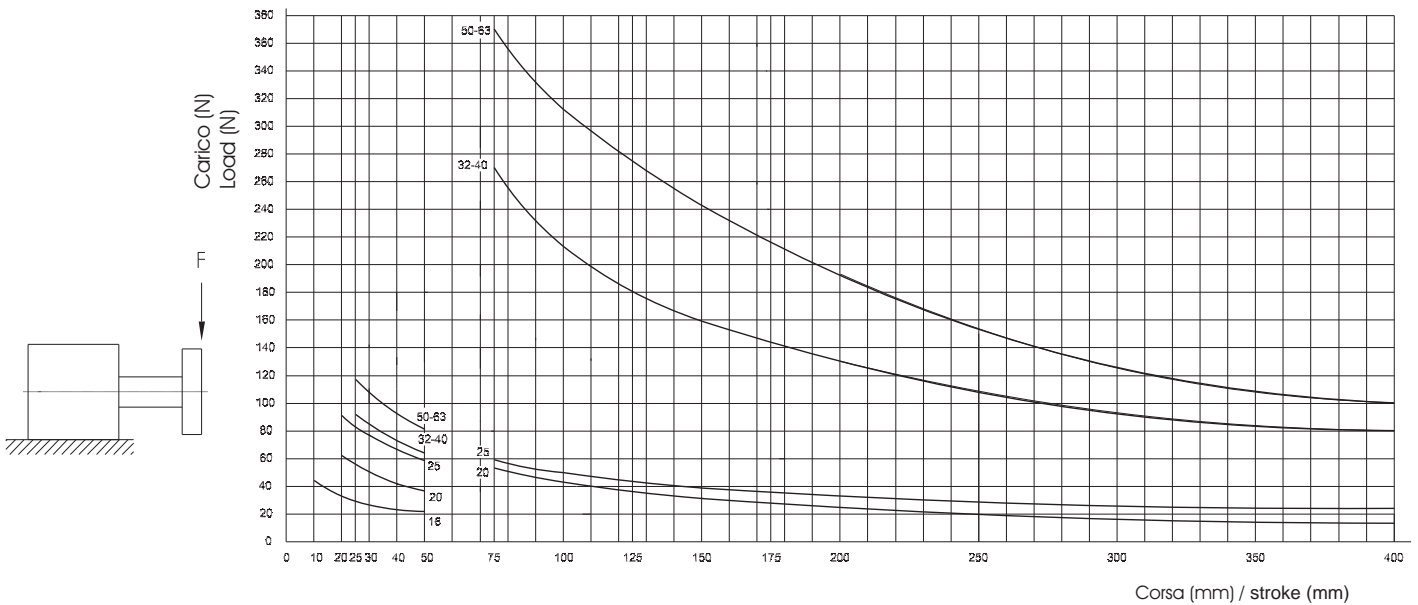

Ø mm	CARICO (N)															
16	44	34		27	23	21	18	15	13	11	9.5	7.5	5			
20		62		50	42	36	53	42	36	31	27	25	20	16	14	
25			94	79	68	60	59	50	43	39	35	33	28.5	26	24.5	
32				84			58	270	213	180	159	142	130	112	93	
40					92		64	270	213	180	159	142	130	112	93	
50						117	81	370	312	275	243	216	193	154.5	126	
63							81	370	312	275	243	216	193	154.5	126	
CORSE →	10	20	25	30	40	50	75	100	125	150	175	200	250	300	350	400

MOMENTO TORCENTE / TORQUE

CON BUSSOLE AUTOLUBRIFICANTI
WITH SLIDE BEARINGS

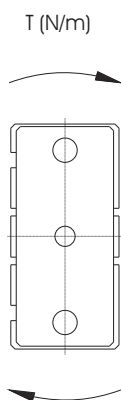

Ø mm	MOMENTO (Nm)															
	10	20	25	30	40	50	75	100	125	150	175	200	250	300	350	400
16	0.69	0.58		0.49	0.43	0.38	0.69	0.58	0.50	0.44	0.40	0.36	0.30			
20		1.05		0.93	0.83	0.75	1.88	1.63	1.44	1.28	1.16	1.06	0.90	0.78	0.69	0.62
25		1.98		1.67	1.45	1.28	2.8	2.50	2.1	1.80	1.65	1.42	1.30	1.22	1.06	0.92
32			5.13			4.19	4.97	4.36	3.46	3.2	3	2.84	2.48	2.20	2	1.84
40			5.13			4.19	4.97	4.36	3.46	3.2	3	2.84	2.48	2.20	2	1.84
50			8.00			5.80	7.00	6.72	5.68	5.25	4.88	4.5	4.2	3.89	3.5	3.18
63			8.00			5.80	7.00	6.72	5.68	5.25	4.88	4.5	4.2	3.89	3.5	3.18
CORSE →	10	20	25	30	40	50	75	100	125	150	175	200	250	300	350	400

CON MANICOTTI A RICIRCOLO DI SFERE
WITH BALL BUCHINGS

Ø mm	MOMENTO (Nm)															
	10	20	25	30	40	50	75	100	125	150	175	200	250	300	350	400
16	0.83	0.65		0.52	0.44	0.40	0.65	0.52	0.43	0.37	0.32	0.28	0.23			
20		1.20		0.96	0.81	0.69	1.02	0.93	0.82	0.71	0.64	0.58	0.52	0.46	0.4	0.34
25		2.00		1.69	1.45	1.28	1.26	1.09	0.98	0.87	0.79	0.70	0.62	0.54	0.46	0.38
32			2.04			1.41	6.58	5.19	4.49	3.87	3.58	3.17	2.85	2.54	2.20	1.85
40			2.47			1.72	7.25	5.72	4.49	3.87	3.58	3.17	2.85	2.54	2.20	1.85
50			3.22			2.22	10.17	8.58	7.75	6.86	5.99	5.30	4.80	4.20	3.68	3
63			3.22			2.22	10.17	8.58	7.75	6.86	5.99	5.30	4.80	4.20	3.68	3
CORSE →	10	20	25	30	40	50	75	100	125	150	175	200	250	300	350	400

PESI / WEIGHT

Pesi versione standard / Weight standard version

Ø	10	20	25	30	40	50	75	100	125	150	175	200	250	300	350	400
16	352	402		452	502	552	752	902	1040	1160	1280	1420	1600			
20		689		830	910	990	1310	1510	1625	1740	1855	1970	2200	2520	2940	3280
25		870		990	1080	1260	1680	2100	2500	2900	3300	3700	4200	4600	5000	5400
32			1770			2120	2770	3080	3408	3737	4066	4395	4800	5100	5400	5730
40			1990			2390	2940	3050	3460	3880	4300	4720	5170	5600	6000	6410
50			3355			3955	4755	5355	5955	6555	7155	7755	8355	8655	9255	9555
63			4030			5070	5786	6505	7224	7943	8662	9380	10100	10820	11540	12300

Pesi versione doppia piastra / Weight double plate version

Ø	10	20	25	30	40	50	75	100	125	150	175	200
16	450	513		575	638	700	907	1088				
20		899		1060	1157	1255	1562	1807	1966	2126	2285	2444
25		1196		1347	1469	1680	2078	2577	3056	3535	4014	4304
32			2163			2632	3356	3790	4241	4694	5146	5599
40			2444			2967	3591	3825	4358	4902	5445	5989
50			4401			5159	6063	6855	7648	8441	9233	10026
63			5397			6630	7450	8361	9273	10184	11096	12006

DOPPIO EFFETTO
DOUBLE ACTING 

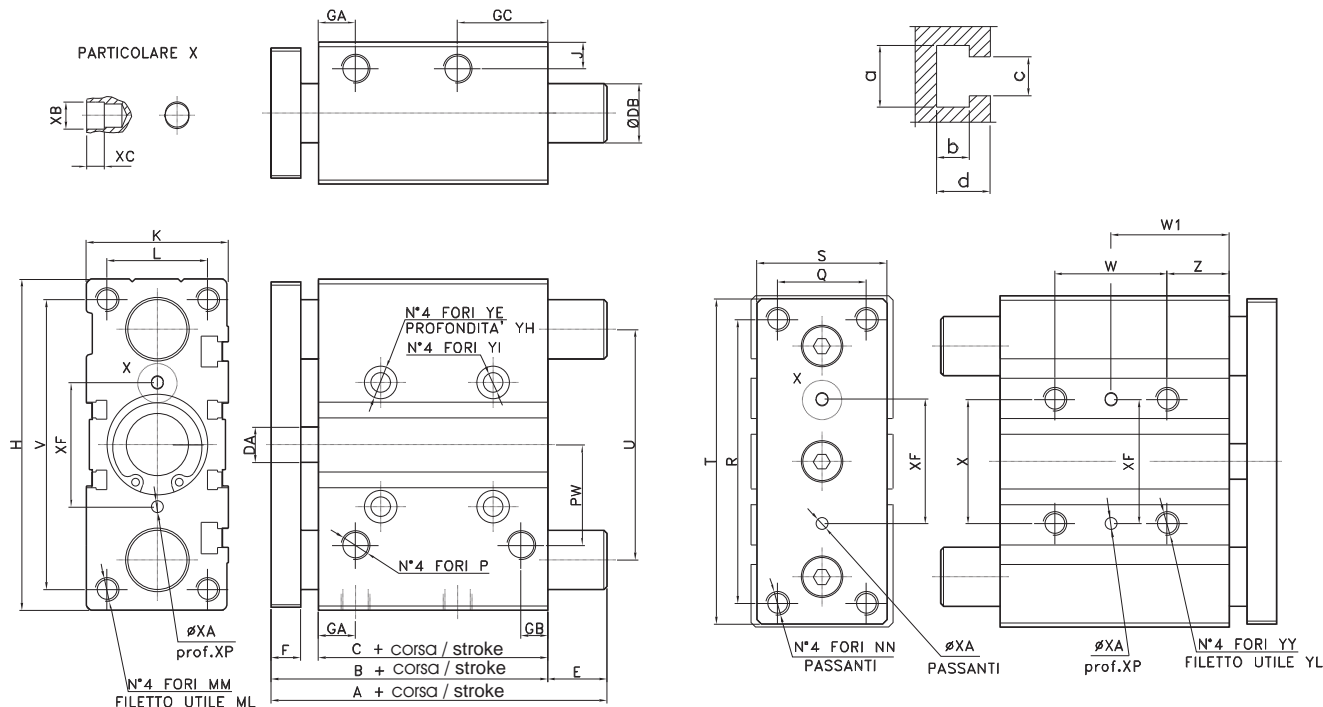

+ = aggiungere la corsa / add the stroke
++ = aggiungere la corsa x 2 / add the stroke x 2

Ø	B	C	DA	F	GA	GB	GC	H	J	K	L	MM	ML	NN	P	PW	Q	R	S	T	U	V	X	YY	YL	YE	YH	YI	Z	XF	XA	XP	XB	XC	a	b	c	d
16	4.6	3.3	8	8	11	8	18	6.4	5	3.0	2.2	M5	12	M5	M5	19	16	5.4	2.5	6.2	4.6	5.6	2.4	M5	10	8	4.5	4.3	5	2.4	3	6	3.5	3	7.4	3.7	4.4	6.2
20	5.3	3.7	10	10	10.5	8.5	24.5	8.3	6.5	3.6	2.4	M5	13	M5	G1/8	25	18	7.0	3.0	8.1	5.4	7.2	2.8	M6	12	9.5	5.5	5.6	17	2.8	3	6	3.5	3	8.4	4.5	5.5	7.3
25	5.3	3.7	10	10	11.5	9	25	9.3	7.5	4.2	3.0	M6	15	M6	G1/8	28.5	26	7.8	3.8	9.1	6.4	8.2	3.4	M6	12	9.5	5.5	5.6	17	3.4	4	6	4.5	3	8.4	4.5	5.5	7.5
32	5.9	3.7	12	12	12.5	9	30.5	11.2	9	4.8	3.4	M8	20	M8	G1/8	34	30	9.6	4.4	11.0	7.8	9.8	4.2	M8	16	11	7.5	6.6	21	4.2	4	6	4.5	3	10.5	5.5	6.5	9
40	6.6	4.4	12	12	14	10	31	12.0	9	5.4	4.0	M8	20	M8	G1/8	38	30	10.4	4.4	11.8	8.6	10.6	5.0	M8	16	11	7.5	6.6	22	5.0	4	6	4.5	3	10.5	5.5	6.5	9
50	7.2	4.4	16	16	14	11	35	14.8	9.5	6.4	4.6	M10	22	M10	G1/4	47	40	13.0	6.0	14.6	11.0	13.0	6.6	M10	20	14	9	8.6	24	6.6	5	8	6	4	13.5	7.5	8.5	12
63	7.7	4.9	16	16	16.5	13.5	35	16.2	11	7.8	5.8	M10	22	M10	G1/4	55	50	13.0	7.0	15.8	12.4	14.2	8.0	M10	20	14	9	8.6	24	8.0	5	8	6	4	17.8	10	11	16.5

CON BUSSOLE AUTOLUBRIFICANTI WITH SLIDE BEARINGS						
Ø	quota A (CORSE-STROKES)			quota E (CORSE-STROKES)		DB
	10-50	75-100	125-250	10-50	75-100	
16	4.6	6.4	9.5	0	18.5	10
Ø	quota A (CORSE-STROKES)			quota E (CORSE-STROKES)		DB
Ø	20-50	75-200	250-400	20-50	75-200	
20	5.3	8.4	12.2	0	31.5	12
25	5.3	8.5	12.2	0	31.5	16
Ø	quota A (CORSE-STROKES)			quota E (CORSE-STROKES)		DB
Ø	25-50	75-200	250-400	25-50	75-200	
32	9.7	10.7	14.0	3.7	47.5	20
40	9.7	10.7	14.0	3.1	4.1	20
50	10.6	11.8	16.1	3.4	4.6	25
63	10.6	11.8	16.1	2.9	4.1	25

CON MANICOTTI A RICIRCOLO DI SFERE WITH BALL BUSCHINGS							
Ø	quota A (CORSE-STROKES)			quota E (CORSE-STROKES)			DB
	10-30	40-100	125-250	10-30	40-100	125-250	
16	4.6	6.6	9.5	0	2.0	4.9	8
Ø	quota A (CORSE-STROKES)			quota E (CORSE-STROKES)			DB
Ø	20-30	40-200	250-400	20-30	40-200	250-400	
20	5.3	8.5	12.2	0	3.2	6.9	12
25	5.3	8.6	12.2	0	3.2	6.8	12
Ø	quota A (CORSE-STROKES)			quota E (CORSE-STROKES)			DB
Ø	25	50	75-200	25	50	75-200	
32	9.7	9.7	10.7	1.4	3.7	3.7	20
40	9.7	9.7	10.7	1.4	3.1	3.1	20
50	10.6	11.4	11.8	1.6	3.4	4.2	25
63	10.6	11.4	11.8	1.6	2.9	3.7	25

QUOTE W e W1 DIMENSIONS W e W1											
Ø	quota W (CORSE-STROKES)				quota W1 (CORSE-STROKES)						
	10-30	40-100	125-200	250-300	10-30	40-100	125-200	250-300	350-400	400-500	
16	2.4	4.4	11.0	2.00	1.7	2.7	6.0	10.5			
Ø	quota W (CORSE-STROKES)				quota W1 (CORSE-STROKES)						
Ø	20-30	40-100	125-200	250-300	350-400	20-30	40-100	125-200	250-300	350-400	
20	2.4	4.4	1.20	2.00	3.00	2.9	3.9	7.7	11.7	16.7	
25	2.4	4.4	1.20	2.00	3.00	2.9	3.9	7.7	11.7	16.7	
Ø	quota W (CORSE-STROKES)				quota W1 (CORSE-STROKES)						
Ø	25	50-100	125-200	250-300	350-400	25	50-100	125-200	250-300	350-400	
32	2.4	4.8	1.24	2.00	3.00	3.3	4.5	8.3	12.1	17.1	
40	2.4	4.8	1.24	2.00	3.00	3.4	4.6	8.4	12.2	17.2	
50	2.4	4.8	1.24	2.00	3.00	3.6	4.8	8.6	12.4	17.4	
63	2.8	5.2	1.28	2.00	3.00	3.8	5.0	8.8	12.4	17.4	

DOPPIA PIASTRA
DOUBLE PLATE

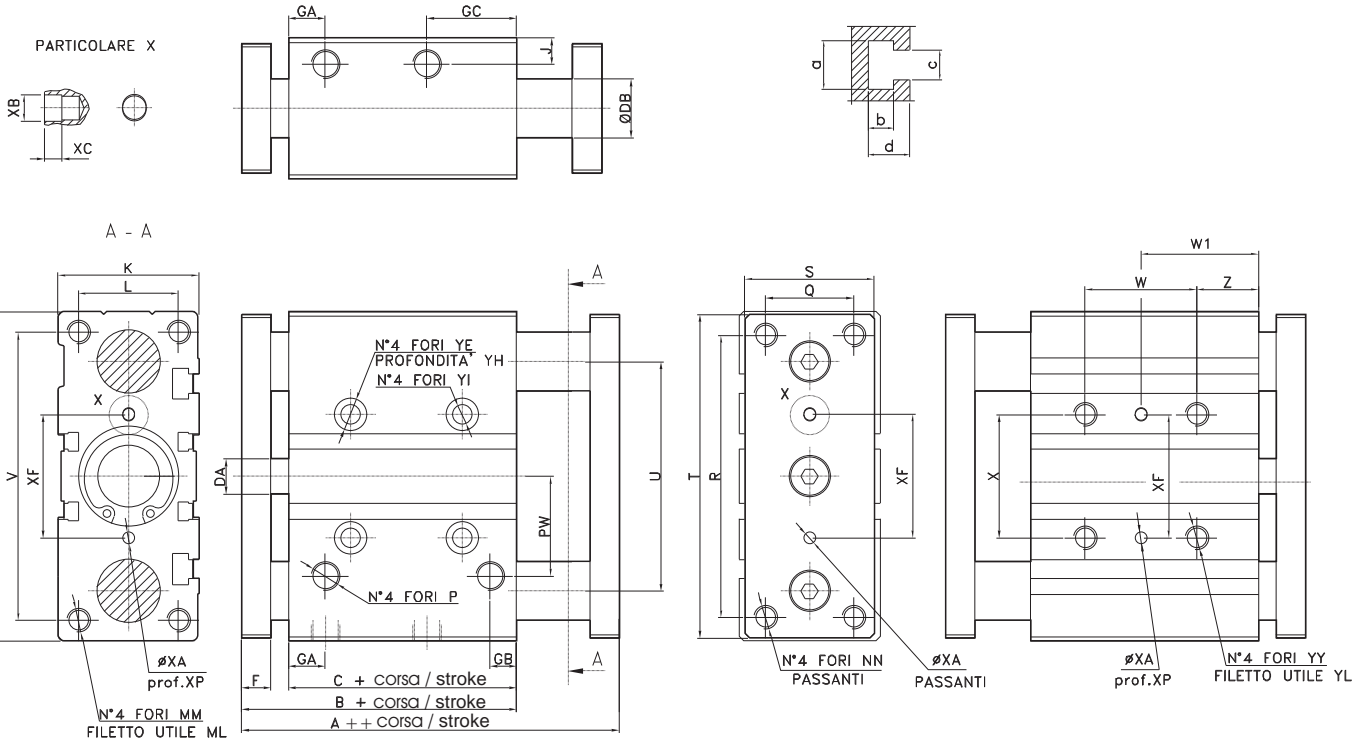
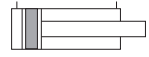

+ = aggiungere la corsa / add the stroke
++ = aggiungere la corsa x 2 / add the stroke x 2

Ø	A	B	C	DA	F	GA	GB	GC	H	J	K	L	MM	ML	NN	P	PW	Q	R	S	T	U	V	X	XF	XA	XP	XB	XC	YY	YL	YE	YH	YI	Z	a	b	c	d
16	59	46	33	8	8	11	8	18	64	5	30	22	M5	12	M5	M5	19	16	54	25	62	46	56	24	24	3	6	3.5	3	M5	10	8	4.5	4.3	5	7.4	3.7	4.4	6.2
20	69	53	37	10	10	10.5	8.5	24.5	83	6.5	36	24	M5	13	M5	G1/8	25	18	70	30	81	54	72	28	28	3	6	3.5	3	M6	12	9.5	5.5	5.6	17	8.4	4.5	5.5	7.3
25	69.5	53.5	37.5	10	10	11.5	9	25	93	7.5	42	30	M6	15	M6	G1/8	28.5	26	78	38	91	64	82	34	34	4	6	4.5	3	M6	12	9.5	5.5	5.6	17	8.4	4.5	5.5	7.5
32	81.5	59.5	37.5	12	12	12.5	9	30.5	112	9	4.8	34	M8	20	M8	G1/8	34	30	96	44	110	78	98	42	42	4	6	4.5	3	M8	16	11	7.5	6.6	21	10.5	5.5	6.5	9
40	88	66	44	12	12	14	10	31	120	9	54	40	M8	20	M8	G1/8	38	30	104	44	118	86	106	50	50	4	6	4.5	3	M8	16	11	7.5	6.6	22	10.5	5.5	6.5	9
50	100	72	44	16	16	14	11	35	148	9.5	64	46	M10	22	M10	G1/4	47	40	130	60	146	110	130	66	66	5	8	6	4	M10	20	14	9	8.6	24	13.5	7.5	8.5	12
63	105	77	49	16	16	16.5	13.5	35	162	11	78	58	M10	22	M10	G1/4	55	50	130	70	158	124	142	80	80	5	8	6	4	M10	20	14	9	8.6	24	17.8	10	11	16.5

QUOTE W e W1 DIMENSIONS W e W1						
Ø	quota W (CORSE-STROKES)			quota W1 (CORSE-STROKES)		
16	24	44		17	27	
	10-30	40-100		10-30	40-100	
20	24	44	120	29	39	77
	20-30	40-100	125-200	20-30	40-100	125-200
	24	44	120	29	39	77
25	20-30	40-100	125-200	20-30	40-100	125-200
	24	48	124	33	45	83
	25	50-100	125-200	25	50-100	125-200
40	24	48	124	34	46	84
	25	50-100	125-200	25	50-100	125-200
	24	48	124	36	48	86
50	25	50-100	125-200	25	50-100	125-200
	28	52	128	38	50	88
	25	50-100	125-200	25	50-100	125-200

Ø	DB Bronzine	DB Manicotti
16	10	8
20	12	12
25	16	12
32	20	20
40	20	20
50	25	25
63	25	25

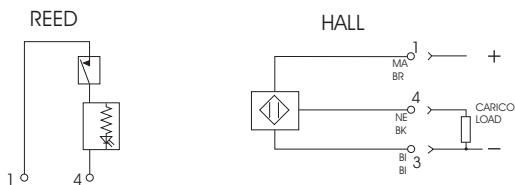
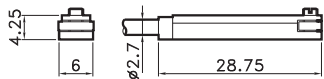
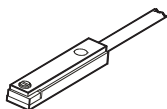

SENSORE A T
"T" SWITCH
CODE

AR4023010	REED 2 FILI (MT.2,5) / REED WITH 2 WIRES (MT.2,5)
AR4023020	HALL 3 FILI (MT.2,5) / HALL WITH 3 WIRES (MT.2,5)
AR4023110	REED 2 FILI + M8 (CM 30) / REED WITH 2 WIRES WITH M8
AR4023120	HALL 3 FILI + M8 (CM 30) / HALL WITH 3 WIRES WITH M8

DATI TECNICI / TECHNICAL DATA

Grado di protezione / Protection class	IP 67 EN 60529
Temp. di impiego / Working temp.	-20C° +85C°
Materiale custodia / Housing material	PA
Tensione in DC / Tension in DC	Reed 3-30V / Hall 6-30V
Tensione in AC / Tension in AC	Reed 3-30V
Corrente a 25 C° / Current at 25 C°	Reed 0,20A / Hall 0,20A
Tempo inserzione / On time	Reed 0,5mS / Hall 0,8 uS
Tempo disinserzione / Off time	Reed 0,1mS / Hall 0,3 uS

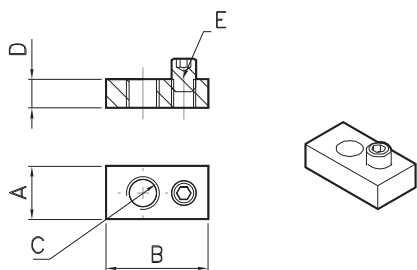

PIASTRINA PER FISSAGGIO
PLATE FOR FIXING

CODE	Ø	A	B	C	D
AR4180016	16	7	10	M4	3.5
AR4180020	20-25	8	15	M5	4
AR4180032	32-40	10	20	M6	5
AR4180050	50	13	25	M8	7
AR4180063	63	17	30	M10	9.5

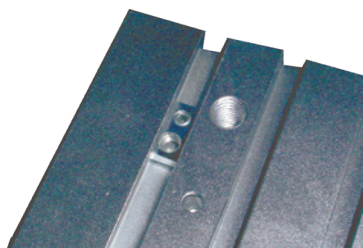



I cilindri corsa breve, sono stati realizzati per garantire buone prestazioni in spazi molto ridotti. Sono disponibili versioni: doppio effetto e con stelo passante. Sul corpo dei cilindri sono ricavate delle cave dove si alloggiano i sensori.

Airwork short stroke Cylinders are engineered to guarantee good performances in very reduced spaces. They are available in different version : double acting and through rod. The body has grooves for the installation of sensors.

CHIAVE DI CODIFICA / KEY TO TYPE NUMBER

CE 00,3,6,000,000

- CORSA / STROKE
- Ø CILINDRO / Ø CYLINDER
- 5=NON MAGNETICO / NO MAGNETIC
6=MEGNETICO / MAGNETIC
- VERSIONE - VERSION
 - 30=DOPPIO EFFETTO / DOUBLE ACTING
 - 31=STELO PASSANTE / THROUGH ROD
 - 32 =STELO MASCHIO / MALE ROD
 - 34=ANTIROTAZIONE / NO ROTATING
 - 35=SEMPLICE EFFETTO MOLLA ANTERIORE / SINGLE ACTING FRONT SPRING
 - 36=SEMPLICE EFFETTO MOLLA POSTERIORE / SINGLE ACTING REAR SPRING

VERSIONE - VERSION

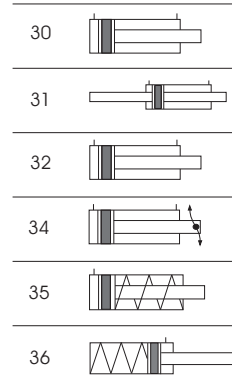

CORSE STANDARD - STANDARD STROKES

corse doppio effetto - double acting strokes

Ø16	mm 5-10-25-30-40
Ø20	mm 5-10-25-30-40-50
Ø25	mm 5-10-25-30-40-50
Ø32	mm 5-10-25-30-40-50
Ø40	mm 5-10-25-30-40-50
Ø50	mm 5-10-25-30-40-50
Ø63	mm 5-10-25-30-40-50-75
Ø80	mm 5-10-25-30-40-50-75-100
Ø100	mm 5-10-25-30-40-50-75-100

corse semplice effetto - simple acting strokes

Ø16	mm 5-10-25
Ø20	mm 5-10-25
Ø25	mm 5-10-25
Ø32	mm 5-10-25-30-40-50
Ø40	mm 5-10-25-30-40-50
Ø50	mm 5-10-25-30-40-50
Ø63	mm 5-10-25-30-40-50

DATI TECNICI / TECHNICAL DATA

Fluido - Fluid	Aria con o senza lubrificazione - Lubricated or non lubricated air
Temperatura di esercizio - Operating temperature range	-20C° / +80C°
Pressione massima di esercizio - Max operating pressure	10 bar
Forze sviluppate - Force	pag.datì tecnici / technical informations page
Consumo aria - Air consumption	pag.datì tecnici / technical informations page

COMPONENTI / COMPONENTS

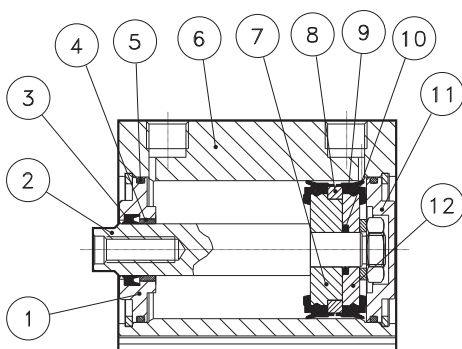

pos.	descrizione / description	materiale / material
1	testata anteriore / front cap	alluminio / aluminium
2	stelo / rod	acciaio C40 crom. / steel C40 chromed
3	guarnizione stelo / rod seal	poliuretano / polyurethane
4	bussola guida / guide bush	bronzo / bronze
5	o-ring	NBR
6	tubo / tube	alluminio / aluminium
7	pistone / piston	alluminio / aluminium
8	magnete / magnet	plastroferrite
9	guarnizione pist. / seal piston	poliuretano / polyurethane
10	o-ring	NBR
11	testata posteriore / rear cap	alluminio / aluminium
12	pistone / piston	alluminio / aluminium

DOPPIO EFFETTO
DOUBLE ACTING

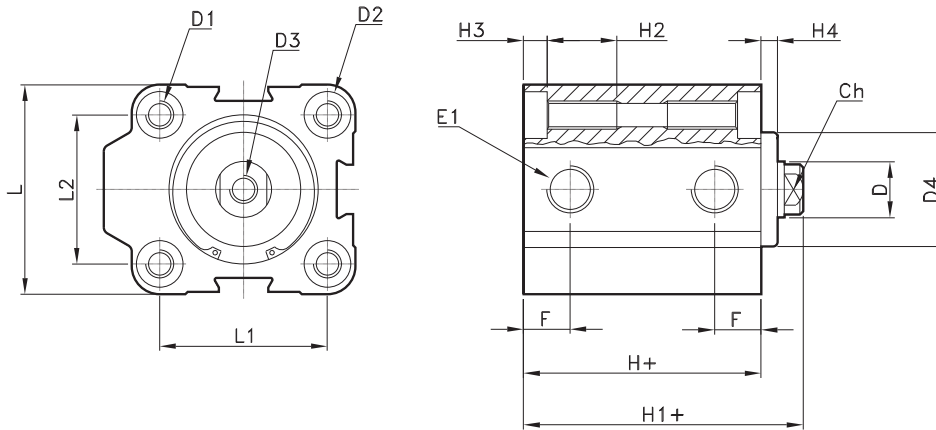
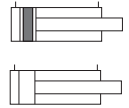

+ = aggiungere la corsa / add the stroke
++ = aggiungere la corsa x 2 / add the stroke x 2

Alesaggio cilindro(mm)	D ø	D1	D2 ø	D3	D4 ø	E1	F	H	H1	H2	H3	H4	L	L1	L2	Ch
16	8	M4	6	M5	-	M5	8	31	35.5	10	3.5	-	28	20	20	7
20	10	M5	7	M5	-	M5	8.5	31	35.5	12	4.5	-	32	22	22	8
25	10	M5	7	M5	-	G1/8"	9	33	38.5	12	4.5	-	38	28	26	8
32	12	M6	10	M6	24.5	G1/8"	10	36	45	15	5.5	3.5	45	36	32	10
40	12	M6	10	M6	30	G1/8"	11.5	41	53	15	5.5	5.5	54.5	40	40	10
50	16	M8	12	M8	35	G1/8"	11.5	42	55	20	6.5	5.5	65	50	50	13
63	16	M10	14	M8	35	G1/8"	12	42	57	25	9	6.5	80	62	62	13
80	25	M10	14	M10	44	G1/4"	14	52	70	25	9	10	100	82	82	22
100	25	M12	17	M12	56	G1/4"	15	62	82	30	11	10	124	103	103	22

STELO PASSANTE
THROUGH ROD

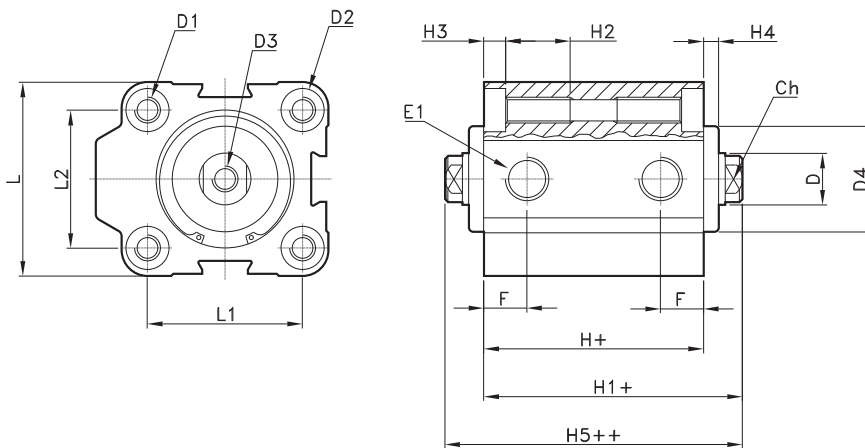
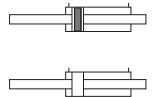

+ = aggiungere la corsa / add the stroke
++ = aggiungere la corsa x 2 / add the stroke x 2

Alesaggio cilindro(mm)	D ø	D1	D2 ø	D3	D4 ø	E1	F	H	H1	H2	H3	H4	H5	L	L1	L2	Ch
16	8	M4	6	M5	-	M5	8	31	35.5	10	3.5	-	40	28	20	20	7
20	10	M5	7	M5	-	M5	8.5	31	35.5	12	4.5	-	40	32	22	22	8
25	10	M5	7	M5	-	G1/8"	9	33	38.5	12	4.5	-	44	38	28	26	8
32	12	M6	10	M6	24.5	G1/8"	10	36	45	15	5.5	3.5	54	45	36	32	10
40	12	M6	10	M6	30	G1/8"	11.5	41	53	15	5.5	5.5	65	54.5	40	40	10
50	16	M8	12	M8	35	G1/8"	11.5	42	55	20	6.5	5.5	68	65	50	50	13
63	16	M10	14	M8	35	G1/8"	12	42	57	25	9	6.5	72	80	62	62	13
80	25	M10	14	M10	44	G1/4"	14	52	70	25	9	10	88	100	82	82	22
100	25	M12	17	M12	56	G1/4"	15	62	82	30	11	10	102	124	103	103	22

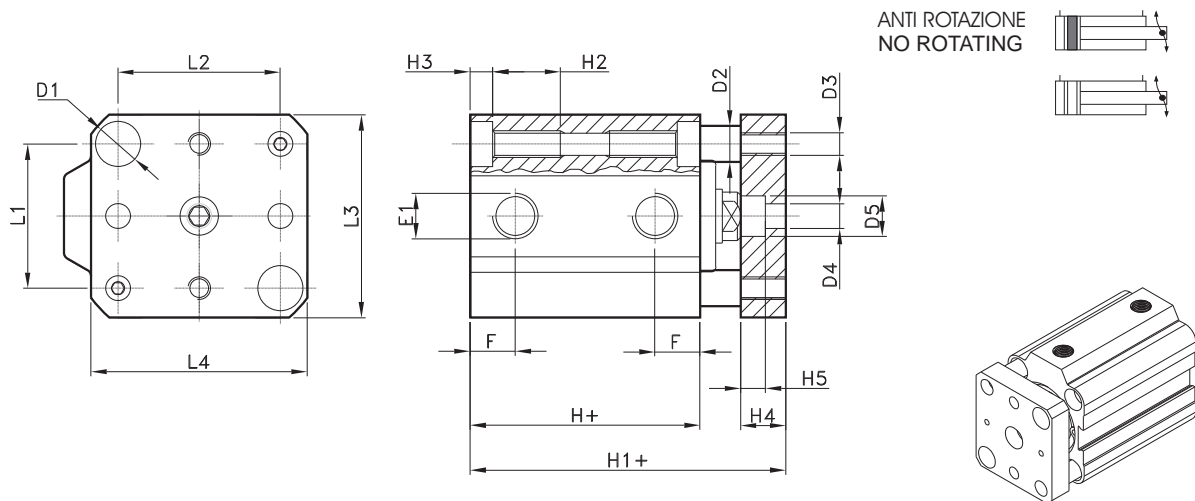

+ = aggiungere la corsa / add the stroke
++ = aggiungere la corsa x 2 / add the stroke x 2

Alesaggio cilindro(mm)	D1 ∅	D2 ∅	D3	D4 ∅	D5 ∅	E1	F	H	H1	H2	H3	H4	H5	L1	L2	L3	L4
16	6	4	M3	3.6	6	M5	8	31	43.5	10	3.5	8	3.5	20	20	28	28
20	7	6	M4	4.5	7.5	M5	8.5	31	43.5	12	4.5	8	4.5	22	22	32	32
25	7	6	M4	4.5	7.5	G1/8"	9	33	46.5	12	4.5	8	4.5	26	28	38	39
32	10	8	M5	5.5	9	G1/8"	10	36	55	15	5.5	10	5.5	32	36	45	48
40	10	8	M5	5.5	9	G1/8"	11.5	41	63	15	5.5	10	5.5	40	40	54.5	54.5
50	12	10	M6	7	11	G1/8"	11.5	42	67	20	6.5	12	6.5	50	50	65	65
63	14	10	M6	7	11	G1/8"	12	42	69	25	9	12	6.5	62	62	80	80
80	14	12	M8	8.5	14	G1/4"	14	52	85	25	9	15	8.5	82	82	100	100
100	17	12	M8	8.5	14	G1/4"	15	62	97	30	11	15	8.5	103	103	124	124

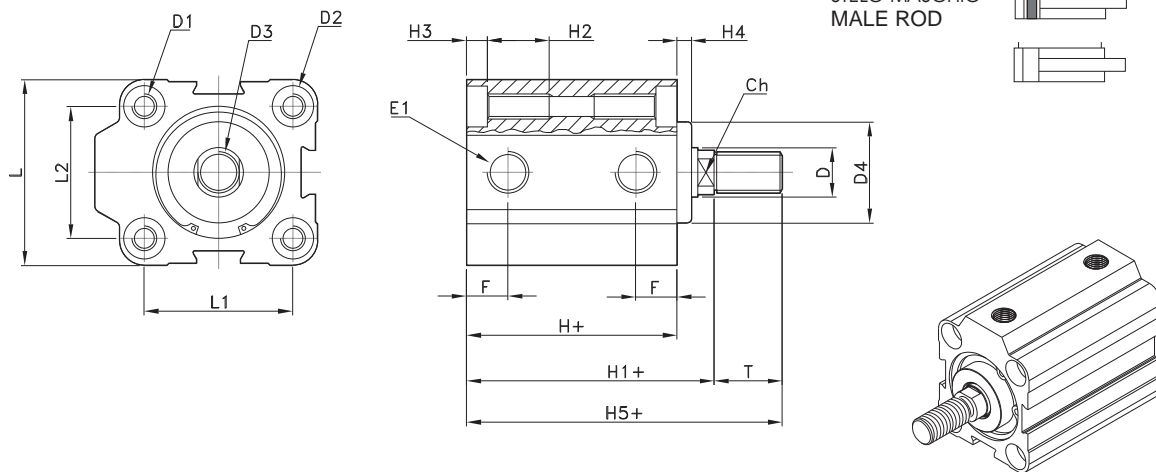

+ = aggiungere la corsa / add the stroke
++ = aggiungere la corsa x 2 / add the stroke x 2

Alesaggio cilindro(mm)	D ∅	D1	D2 ∅	D3	D4 ∅	E1	F	H	H1	H2	H3	H4	H5	L	L1	L2	Ch	T
16	8	M4	6	M6	-	M5	8	31	35.5	10	3.5	-	55.5	28	20	20	7	18
20	10	M5	7	M8	-	M5	8.5	31	35.5	12	4.5	-	55.5	32	22	22	8	20
25	10	M5	7	M8	-	G1/8"	9	33	38.5	12	4.5	-	60.5	38	28	26	8	20
32	12	M6	10	M10x1.25	24.5	G1/8"	10	36	45	15	5.5	3.5	67	45	36	32	10	22
40	12	M6	10	M10x1.25	30	G1/8"	11.5	41	53	15	5.5	5.5	77	54.5	40	40	10	22
50	16	M8	12	M12x1.25	35	G1/8"	11.5	42	55	20	6.5	5.5	87	65	50	50	13	24
63	16	M10	14	M12x1.25	35	G1/8"	12	42	57	25	9	6.5	89	80	62	62	13	24
80	25	M10	14	M20x1.5	44	G1/4"	14	52	70	25	9	10	110	100	82	82	22	32
100	25	M12	17	M20x1.5	56	G1/4"	15	62	82	30	11	10	122	124	103	103	22	32

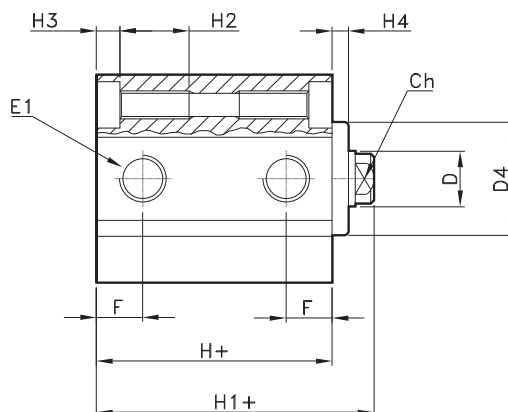
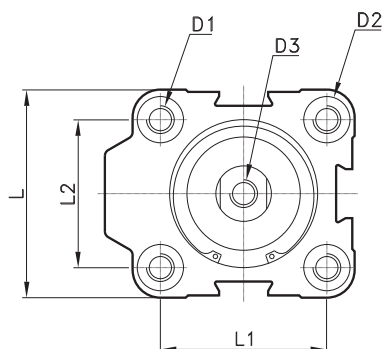

SEMPLICE EFFETTO
SINGLE ACTING

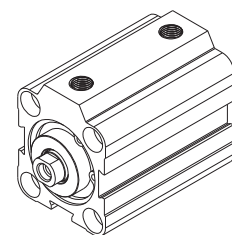
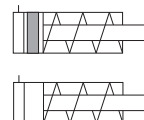

+ = aggiungere la corsa / add the stroke
++ = aggiungere la corsa x 2 / add the stroke x 2

Alesaggio cilindro(mm)	D ø	D1	D2 ø	D3	D4 ø	E1	F	H	H1	H2	H3	H4	L	L1	L2	Ch
16	8	M4	6	M5	-	M5	8	31	35.5	10	3.5	-	28	20	20	7
20	10	M5	7	M5	-	M5	8.5	31	35.5	12	4.5	-	32	22	22	8
25	10	M5	7	M5	-	G1/8"	9	33	38.5	12	4.5	-	38	28	26	8
32	12	M6	10	M6	24.5	G1/8"	10	36	45	15	5.5	3.5	45	36	32	10
40	12	M6	10	M6	30	G1/8"	11.5	41	53	15	5.5	5.5	54.5	40	40	10
50	16	M8	12	M8	35	G1/8"	11.5	42	55	20	6.5	5.5	65	50	50	13
63	16	M10	14	M8	35	G1/8"	12	42	57	25	9	6.5	80	62	62	13
80	25	M10	14	M10	44	G1/4"	14	52	70	25	9	10	100	82	82	22
100	25	M12	17	M12	56	G1/4"	15	62	82	30	11	10	124	103	103	22

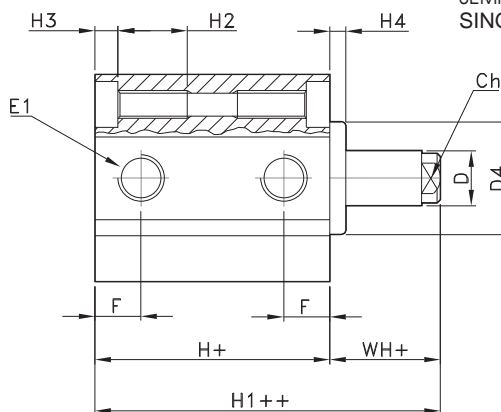
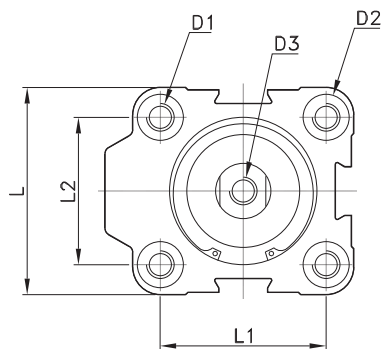

SEMPLICE EFFETTO
SINGLE ACTING

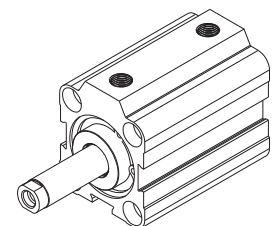
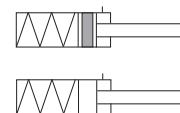

+ = aggiungere la corsa / add the stroke
++ = aggiungere la corsa x 2 / add the stroke x 2

Alesaggio cilindro(mm)	D ø	D1	D2 ø	D3	D4 ø	E1	F	H	H1	H2	H3	H4	L	L1	L2	Ch	WH
16	8	M4	6	M5	-	M5	8	31	35.5	10	3.5	-	28	20	20	7	4.5
20	10	M5	7	M5	-	M5	8.5	31	35.5	12	4.5	-	32	22	22	8	4.5
25	10	M5	7	M5	-	G1/8"	9	33	38.5	12	4.5	-	38	28	26	8	5.5
32	12	M6	10	M6	24.5	G1/8"	10	36	45	15	5.5	3.5	45	36	32	10	9
40	12	M6	10	M6	30	G1/8"	11.5	41	53	15	5.5	5.5	54.5	40	40	10	12
50	16	M8	12	M8	35	G1/8"	11.5	42	55	20	6.5	5.5	65	50	50	13	13
63	16	M10	14	M8	35	G1/8"	12	42	57	25	9	6.5	80	62	62	13	15
80	25	M10	14	M10	44	G1/4"	14	52	70	25	9	10	100	82	82	22	18
100	25	M12	17	M12	56	G1/4"	15	62	82	30	11	10	124	103	103	22	20

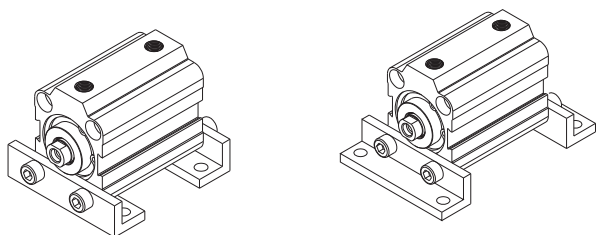
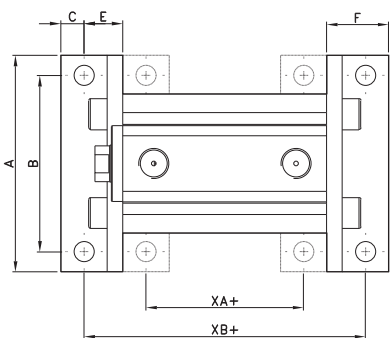
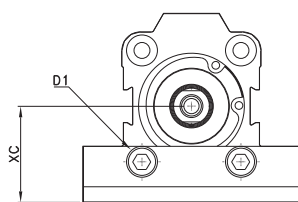
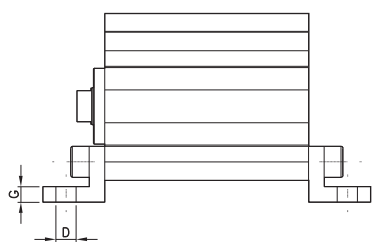

PIEDINO / PEDESTAL

CODE	Ø
AR4201016	16
AR4201020	20
AR4201025	25
AR4201032	32
AR4201040	40
AR4201050	50
AR4201063	63
AR4201080	80
AR4201100	100

Ø	A	B	C	D Ø	D1 Ø	E	F	G	XA	XB	XC
16	48	37	5	6.5	M4	10	8	5	16	46	20.5
20	54	42.5	5	5.5	M5	10	8.5	5	16	46	21.5
25	62	48.5	7.5	5.5	M5	12.5	9	5	17.5	57.5	27.5
32	70	57	7.5	6.5	M6	12.5	20	5	21	61	31
40	80	66.5	7.5	6.5	M6	12.5	11.5	5	23	63	34.3
50	100	80	10	8.5	M8	15	11.5	5	22	72	42.5
63	118	98	10	10.5	M10	15	12	5	24	74	47.5
80	141	118	15	10.5	M10	20	14	5	20	90	60
100	169	144	15	13	M12	20	15	5	27	97	72

Materiale: Acciaio
Material: Steel

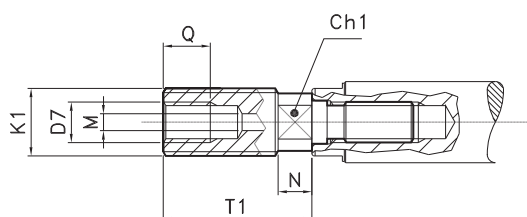

ADATTATORE PER STELO MASCHIO /
ADAPTOR FOR MALE ROD

CODE	Ø
AR402820	20
AR402825	25
AR402832	32
AR402840	40
AR402850	50
AR402863	63

Ø	D7	M	T1	Q	N	Ch1	K1
20	M5	2	22	10	5	7	M10x1.25
25	M5	2	22	10	5	7	M10x1.25
32	M6	2	22	10	5	7	M10x1.25
40	M6	2	22	10	5	7	M10x1.25
50	M8	3.5	24	12	5	9	M12x1.25
63	M8	3.5	24	12	5	9	M12x1.25

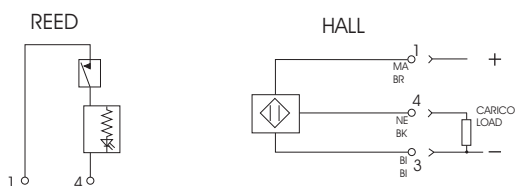
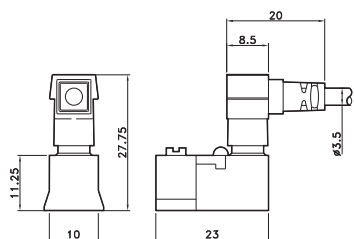

SENSORE MAGNETICO
MAGNETIC SWITCH
CODE

AR4025110	REED 2 FILI (MT.2,5) / REED WITH 2 WIRES (MT.2,5)
AR4025120	HALL 3 FILI (MT.2,5) / HALL WITH 3 WIRES (MT.2,5)

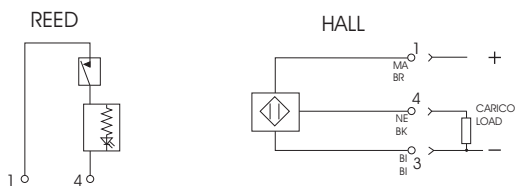
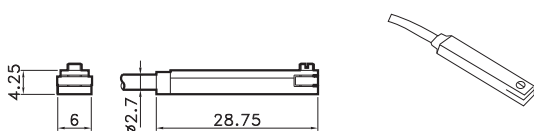

SENSORE A T
"T" SWITCH
CODE

AR4023010	REED 2 FILI (MT.2,5) / REED WITH 2 WIRES (MT.2,5)
AR4023020	HALL 3 FILI (MT.2,5) / HALL WITH 3 WIRES (MT.2,5)
AR4023110	REED 2 FILI + M8 (CM 30) / REED WITH 2 WIRES WITH M8
AR4023120	HALL 3 FILI + M8 (CM 30) / HALL WITH 3 WIRES WITH M8

DATI TECNICI / TECHNICAL DATA

Grado di protezione / Protection class	IP 67 EN 60529
Temp. di impiego / Working temp.	-20C° +85C°
Materiale custodia / Housing material	PA
Tensione in DC / Tension in DC	Reed 3-30V / Hall 6-30V
Tensione in AC / Tension in AC	Reed 3-30V
Corrente a 25 C° / Current at 25 C°	Reed 0,20A / Hall 0,20A
Tempo inserzione / On time	Reed 0,5mS / Hall 0,8 uS
Tempo disinserzione / Off time	Reed 0,1 mS / Hall 0,3 uS

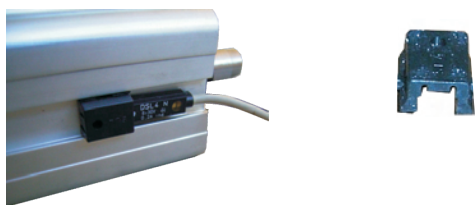

ADATTATORE PER SENSORE A T
ADAPTOR FOR T SWITCH
CODE

AR40060

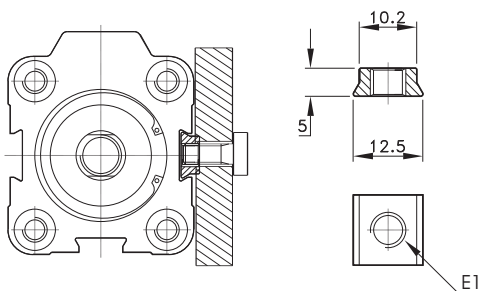

PIASTRINE PER FISSAGGIO A PARETE / FIXING NUT

CODE	Ø
AR4231032	16-32
AR4231100	32-100

Ø	E1
16-32	M5
32-100	M6



Il cilindro senza stelo nasce dall'esigenza di ridurre gli ingombri a parità di corsa. È fornito in diverse versioni e gli alesaggi variano da 25 a 63. I pregi principali di questo cilindro sono l'eccezionale robustezza del pistone/carrello e il sistema di tenuta garantisce una lunga vita del cilindro anche in presenza di temperature e velocità elevate.

Air Work's rodless cylinders are born from the requirement to reduce dimensions thus granting the same stroke dimension. They are available in several versions and the bores vary from 25 to 63. Main feature of this cylinder is the exceptional toughness of the guide while the sealing system guarantees a long life of the cylinder also in presence of high temperature and speed.

CHIAVE DI CODIFICA / KEY TO TYPE NUMBER

SS,00,1,000,0000

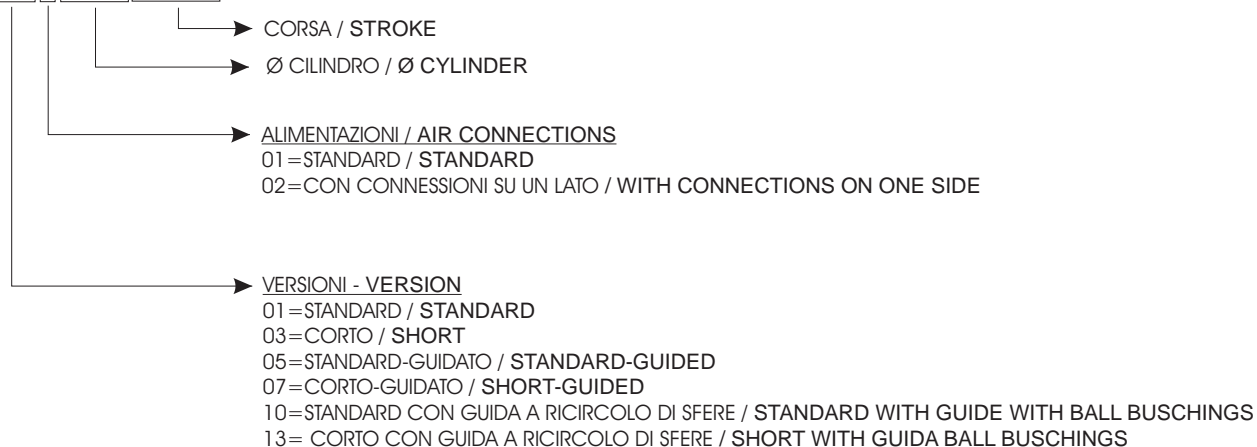

DATI TECNICI / TECHNICAL DATA

Fluido - Fluid	Aria con o senza lubrificazione - Lubricated or non lubricated air
Temperatura di esercizio - Operating temperature range	-10C° / +70C°
Pressione massima di esercizio - Max operating pressure	1 - 8 bar
Velocità massima - Maximum speed	2.0 m/sec
Corsa massima - Maximum stroke	6000mm

Corsa ammortizzo / cushioning lenght mm	Ø25:24mm	Ø32:28mm	Ø40:36mm	Ø50:45mm	Ø63:59mm
Peso a 0mm / mass at 0mm	Ø25:0,88kg	Ø32:1,40kg	Ø40:2,41kg	Ø50:5,30kg	Ø63:8,10kg
Peso aggiuntivo 100 mm / additional mass 100mm	Ø25:0,30kg	Ø32:0,39kg	Ø40:0,52kg	Ø50:0,96kg	Ø63:1,32kg

COMPONENTI / COMPONENTS

Testate / Caps	Alluminio anodizzato / Anodized aluminium
Profilo / Profile	Alluminio anodizzato / Anodized aluminium
Pistone / Piston	Resina acetale / Acetal
Guarnizioni pistone / Piston seals	Poliuretano / Polyurethane
Bandella di tenuta / Sealing strip	Poliuretano / Polyurethane
Bandella di copertura / Cover strip	Acciaio inossidabile / Stainless steel
Viti di fissaggio / Screws of fixing	Acciaio inossidabile / Stainless steel

FORZA E TORSIONE MASSIMA / MAXIMUM FORCE AND TORQUE DATA

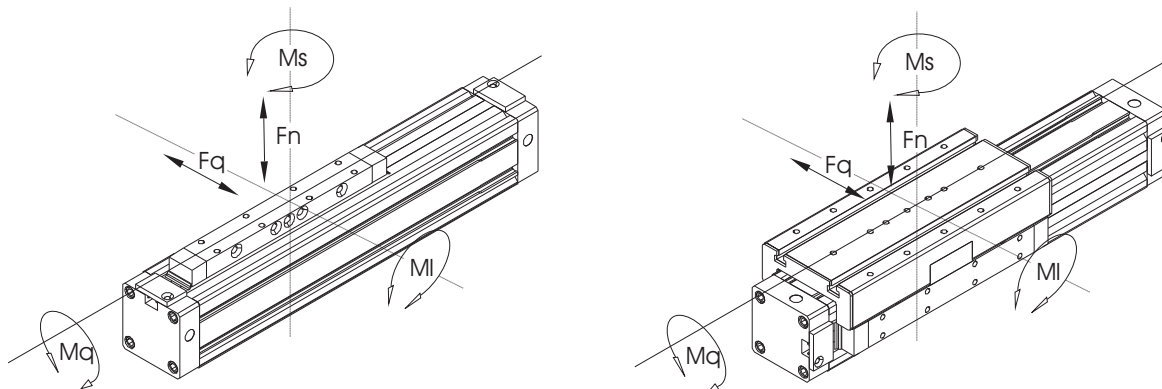

TYPE	Ø	operating force	Fn max	Fq max	MI max	Mq max	Ms max
SS01125	25	255 N	270 N	-	13 Nm	2.5 Nm	11 Nm
SS03125	25	255 N	270 N	-	8 Nm	2.0 Nm	7 Nm
SS05125	25	250 N	580 N	580 N	23 Nm	10.0 Nm	23 Nm
SS07125	25	250 N	340 N	340 N	9 Nm	5.0 Nm	9 Nm
SS10125	25	250 N	850 N	1300 N	65 Nm	35 Nm	105 Nm
SS13125	25	250 N	850 N	1300 N	29 Nm	35 Nm	64 Nm
SS01132	32	420 N	300 N	-	30 Nm	3.0 Nm	24 Nm
SS03132	32	420 N	300 N	-	15 Nm	3.0 Nm	12 Nm
SS05132	32	410 N	850 N	850 N	33 Nm	15.0 Nm	33 Nm
SS07132	32	410 N	460 N	460 N	14 Nm	6.5 Nm	14 Nm
SS10132	32	410 N	900 N	1500 N	79 Nm	40.0 Nm	125 Nm
SS13132	32	410 N	900 N	1500 N	36 Nm	40.0 Nm	76 Nm
SS01140	40	655 N	650 N	-	60 Nm	4.0 Nm	54 Nm
SS03140	40	655 N	650 N	-	30 Nm	4.0 Nm	27 Nm
SS05140	40	640 N	1120 N	1120 N	60 Nm	25.0 Nm	60 Nm
SS07140	40	640 N	600 N	600 N	25 Nm	11.0 Nm	25 Nm
SS10140	40	640 N	1200 N	2000 N	190 Nm	67.0 Nm	118 Nm
SS13140	40	640 N	1200 N	2000 N	85 Nm	67.0 Nm	72 Nm
SS01150	50	1000 N	800 N	-	80 Nm	17.0 Nm	74 Nm
SS03150	50	1000 N	800 N	-	38 Nm	17.0 Nm	32 Nm
SS05150	50	1000 N	1550 N	1500 N	200 Nm	70.0 Nm	200 Nm
SS07150	50	1000 N	820 N	800 N	60 Nm	40.0 Nm	60 Nm
SS10150	50	1000 N	4100 N	2000 N	157 Nm	45.0 Nm	170 Nm
SS13150	50	1000 N	1800 N	2000 N	67 Nm	45.0 Nm	106 Nm
SS01163	63	1600 N	1400 N	-	110 Nm	17.0 Nm	100 Nm
SS03163	63	1600 N	1400 N	-	50 Nm	17.0 Nm	48 Nm
SS05163	63	1600 N	2000 N	2000 N	300 Nm	52.0 Nm	208 Nm
SS07163	63	1600 N	1100 N	1100 N	105 Nm	56.0 Nm	105 Nm
SS10163	63	1600 N	5000 N	2000 N	196 Nm	52.0 Nm	208 Nm
SS13163	63	1600 N	2500 N	2000 N	99 Nm	52.0 Nm	134 Nm

DIAGRAMMA DI AMMORTIZZO / CUSHIONING DIAGRAM

Se l'applicazione è fuori dal diagramma, viene richiesto un ammortizzatore esterno. La posizione di montaggio degli ammortizzatori deve essere vicino al centro della massa.
I dati si riferiscono ad una posizione di montaggio orizzontale.

If the application is out of the diagram range, an external shock absorber is required. The mounting position of shock absorbers must be close to the center of the mass.
The data applies to a horizontal mounting position.

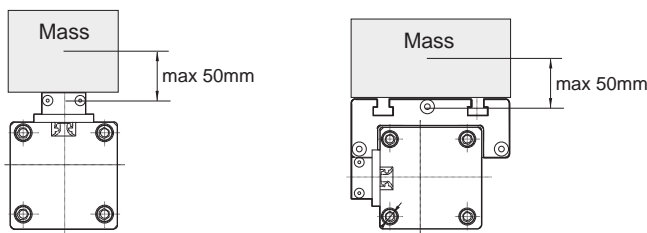
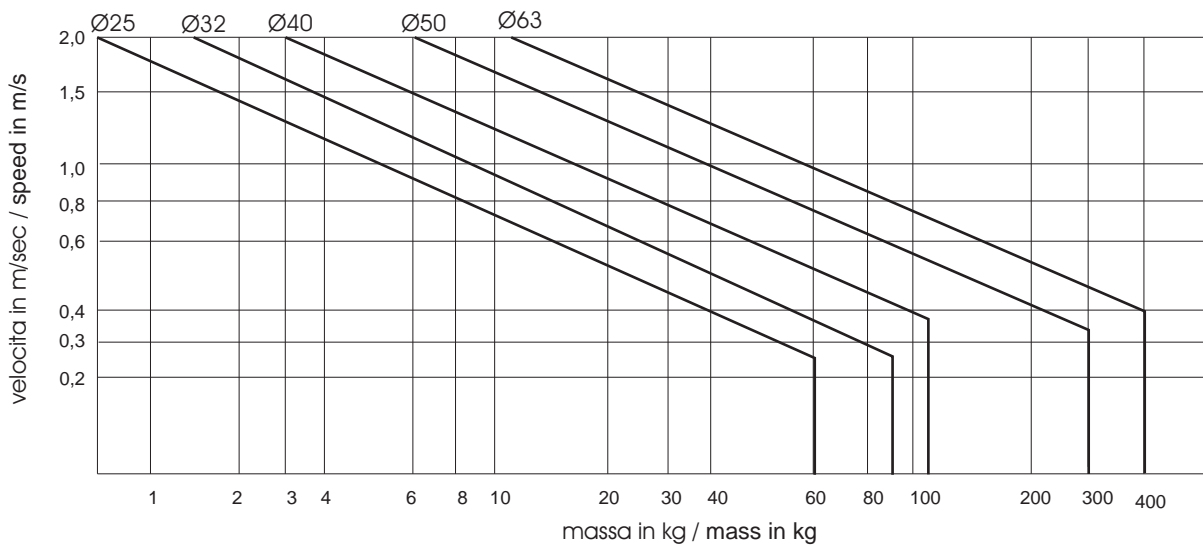

CARICO CON FLESSIONE / DEFLECTION WITH LOAD

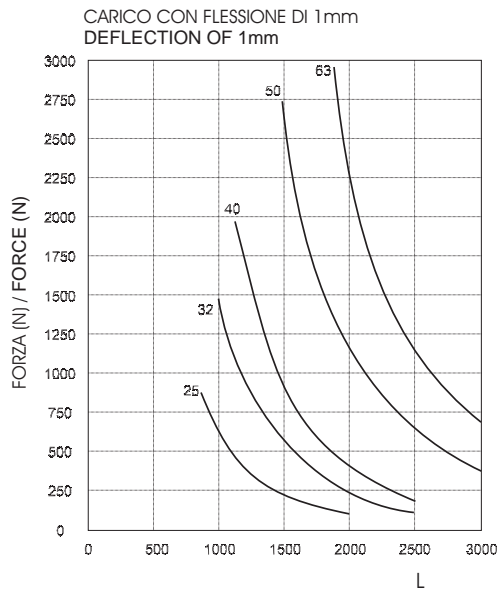
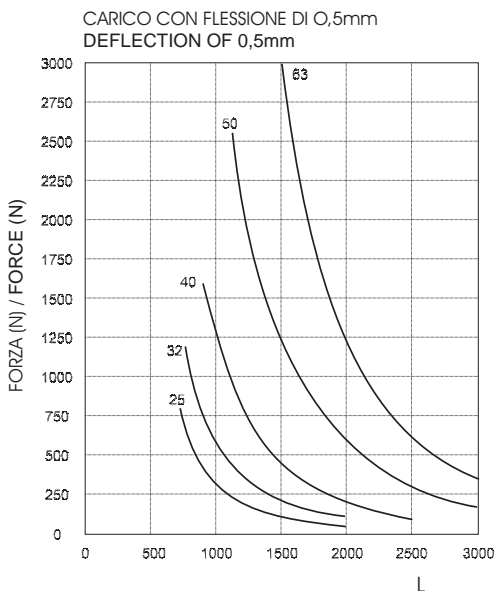
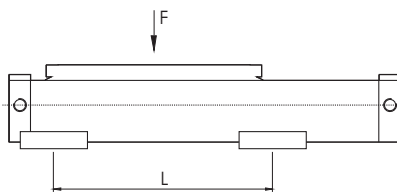

STANDARD
STANDARD

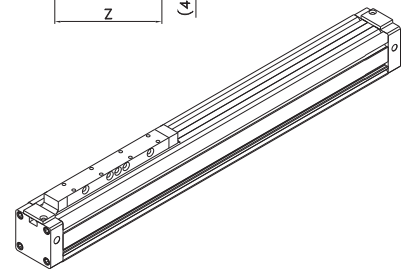
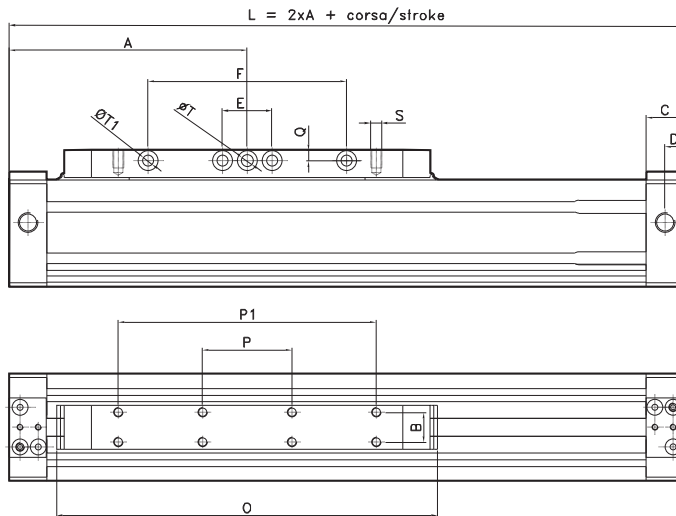

Ø	A	B	C	D	E	F	G	H	O	P	P1	Q	R	S	T	T1	U	V	Z	W
25	100	15	19	9.5	25	70	G1/8"	25	149.5	50	90	5	22	M5x7	6	4.5	36	M4x11	45	60
32	120	15	19	9.5	25	100	G1/8"	32	184.5	45	130	5.5	22	M5x7	6	5.5	41	M5x11	54	69
40	150	15	23	11.5	25	130	G1/4"	38	222.5	90	160	7	22	M5x9	7	6.5	49	M6x12	64	82
50	175	34	30	17	35	180	G3/8"	59	262	60	150	9	46	M8x16	10	8.5	65	M8x17	90	115
63	200	34	30	17	50	180	G3/8"	68.5	300	80	240	9.5	46	M8x16	10	8.5	78	M8x17	106	131

STANDARD CON CONNESSIONI SU UN LATO
STANDARD WITH CONNECTIONS ON ONE SIDE

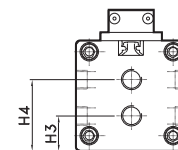
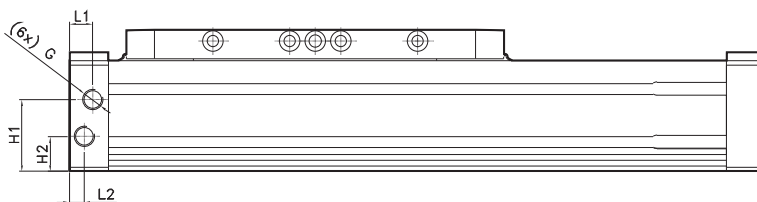

Ø	H1	H2	H3	H4	L1	L2	G
25	28.5	13.5	13.5	29.5	11	8	G1/8"
32	34.5	17.5	17.5	34.5	9.5	9.5	G1/8"
40	42.5	20.5	15.5	38	11.5	11.5	G1/4"
50	59	29	29.5	59	17	17	G3/8"
63	68.5	34	34	68.5	17	17	G3/8"

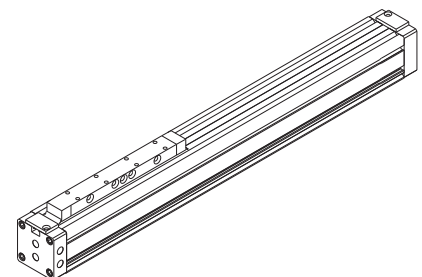

CORTO
SHORT

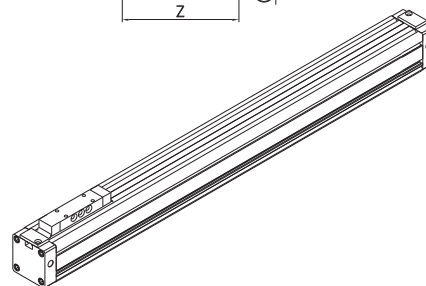
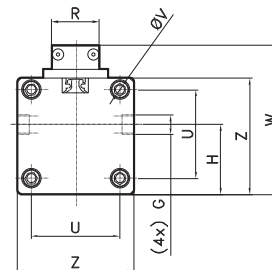
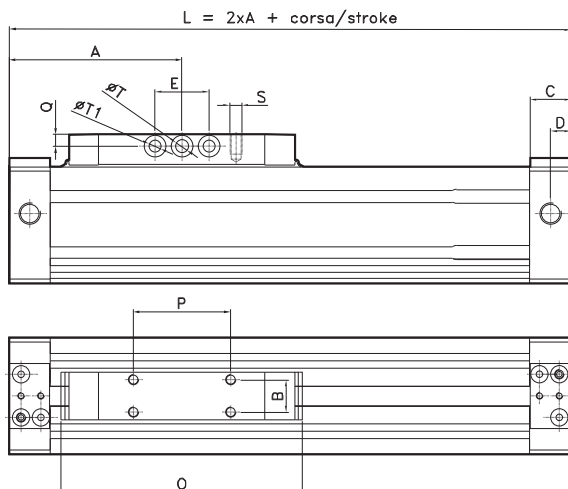

Ø	A	B	C	D	E	G	H	O	P	Q	R	S	T	T1	U	V	Z	W
25	67.5	15	19	9.5	25	G1/8"	25	84.5	35	5	22	M5x7	6	4.5	36	M4x11	45	60
32	77.5	15	19	9.5	25	G1/8"	32.5	99.5	45	5.5	22	M5x7	6	5.5	41	M5x11	54	69
40	95	15	23	11.5	25	G1/4"	38.5	112.5	50	7	22	M5x9	7	6.5	49	M6x12	64	82
50	105	34	30	17	35	G3/8"	59	122	64	9	46	M8x16	10	8.5	65	M8x17	90	115
63	125	34	30	17	50	G3/8"	68.5	150	80	9.5	46	M8x16	10	8.5	78	M8x17	106	131

CORTO CON CONNESSIONI SU UN LATO
SHORT WITH CONNECTIONS ON ONE SIDE

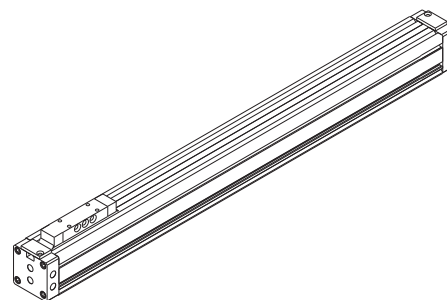
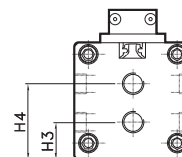
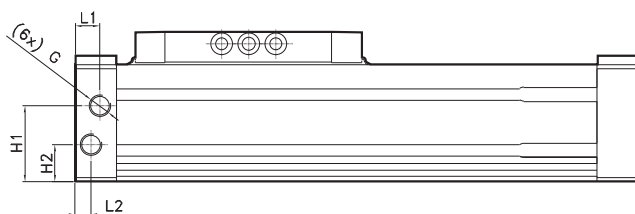

Ø	H1	H2	H3	H4	L1	L2	G
25	28.5	13.5	13.5	29.5	11	8	G1/8"
32	34.5	17.5	17.5	34.5	9.5	9.5	G1/8"
40	42.5	20.5	15.5	38	11.5	11.5	G1/4"
50	59	29	29.5	59	17	17	G3/8"
63	68.5	34	34	68.5	17	17	G3/8"

STANDARD GUIDATO
STANDARD GUIDED

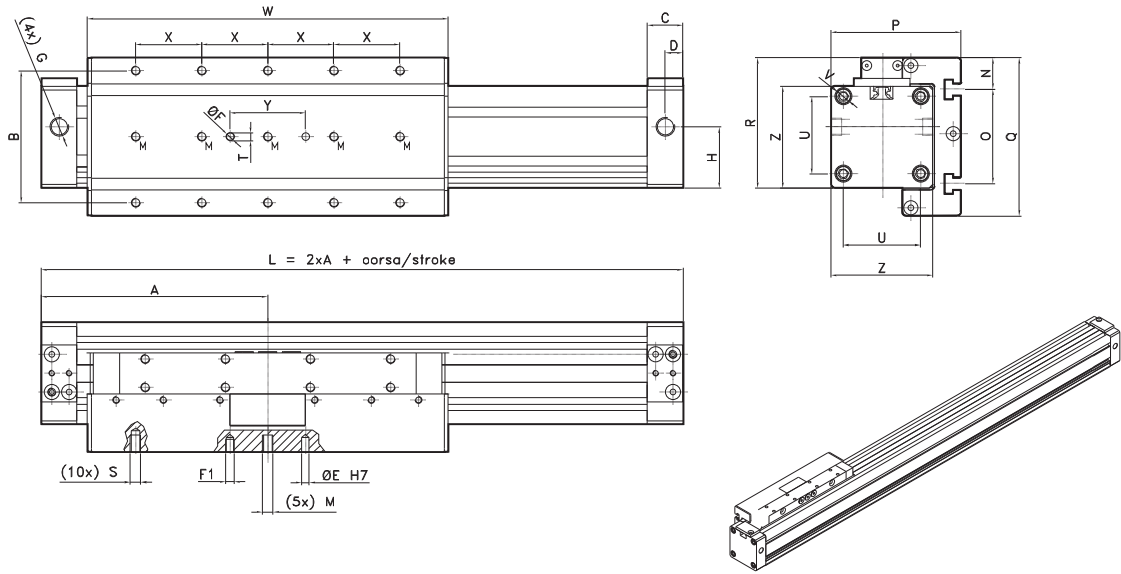

Ø	A	B	C	D	E	F	F1	G	H	M	N	O	P	Q	R	S	T	U	V	Z	X	Y	W
25	100	30	19	9.5	4x5.5	4x5.5	4.5x4.5	G1/8"	25	/	12.5	50	59	75	60	M5x8	4	36	M4x11	45	30	40	159
32	120	70	19	9.5	4x8	4x8	4.5x7	G1/8"	32	M5x9	17	50	69	84	69	M5x11	4	41	M5x11	54	35	40	191
40	150	55	23	11.5	6x8	6x8	6.5x7	G1/4"	38	/	10	80	79	100	82	M6x12	6	49	M6x12	64	55	40	246
50	175	42	30	17	6x3	/	6.5x3	G3/8"	59	/	23	94	112.5	133	115	M8x16	6	65	M8x17	90	50	40	270
63	200	60	30	17	6x6.5	/	6.5x6.5	G3/8"	68.5	/	24	110	134.5	150	132	M8x16	6	78	M8x17	106	60	40	320

STANDARD GUIDATO CON CONNESSIONI SU UN LATO
STANDARD GUIDED WITH CONNECTIONS ON ONE SIDE

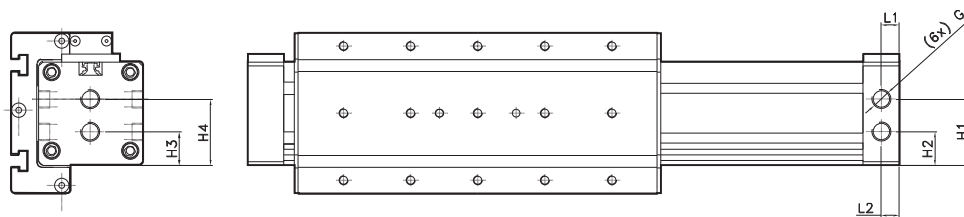

Ø	H1	H2	H3	H4	L1	L2	G
25	28.5	13.5	13.5	29.5	11	8	G1/8"
32	34.5	17.5	17.5	34.5	9.5	9.5	G1/8"
40	42.5	20.5	15.5	38	11.5	11.5	G1/4"
50	59	29	29.5	59	17	17	G3/8"
63	68.5	34	34	68.5	17	17	G3/8"

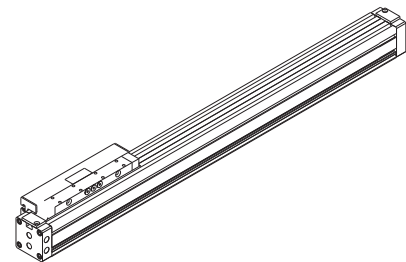

CORTO GUIDATO
SHORT GUIDED

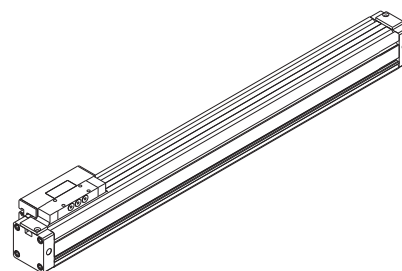
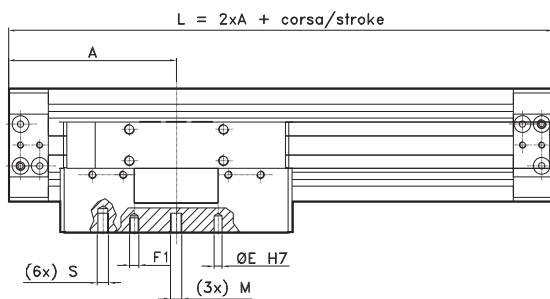
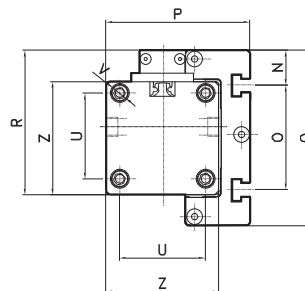
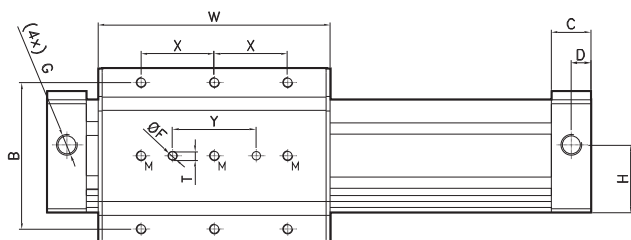

Ø	A	B	C	D	E	F	F1	G	H	M	N	O	P	Q	R	S	T	U	V	Z	X	Y	W
25	67.5	30	19	9.5	4x5.5	4x5.5	4.5x4.5	G1/8"	25	/	12.5	50	59	75	60	M5x8	4	36	M4x11	45	30	40	94
32	77.5	70	19	9.5	4x8	4x8	4.5x7	G1/8"	32.5	M5x9	17	50	69	84	69	M5x11	4	41	M5x11	54	35	40	106
40	95	55	23	11.5	6x8	6x8	6.5x7	G1/4"	38.5	/	10	80	79	100	82	M6x12	6	49	M6x12	64	55	40	136
50	105	42	30	17	6x3	/	6.5x3	G3/8"	59	/	23	94	112.5	133	115	M8x16	6	65	M8x17	90	50	40	148
63	125	60	30	17	6x6.5	/	6.5x6.5	G3/8"	68.5	/	24	110	134.5	150	132	M8x16	6	78	M8x17	106	60	40	180

CORTO GUIDATO CON CONNESSIONI SU UN LATO
SHORT GUIDED WITH CONNECTIONS ON ONE SIDE

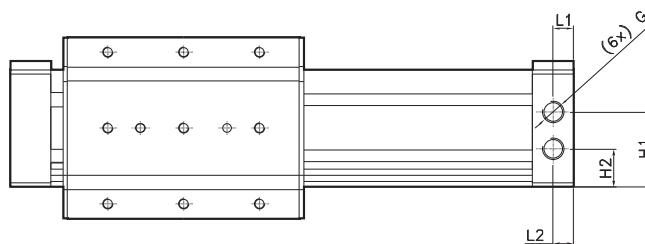
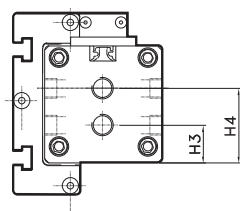

Ø	H1	H2	H3	H4	L1	L2	G
25	28.5	13.5	13.5	29.5	11	8	G1/8"
32	34.5	17.5	17.5	34.5	9.5	9.5	G1/8"
40	42.5	20.5	15.5	38	11.5	11.5	G1/4"
50	59	29	29.5	59	17	17	G3/8"
63	68.5	34	34	68.5	17	17	G3/8"

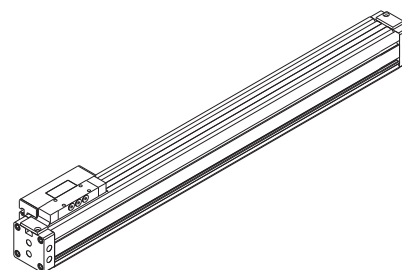

STANDARD CON GUIDA A RICIRCOLO DI SFERE
STANDARD WITH GUIDA BALL BUSCHINGS

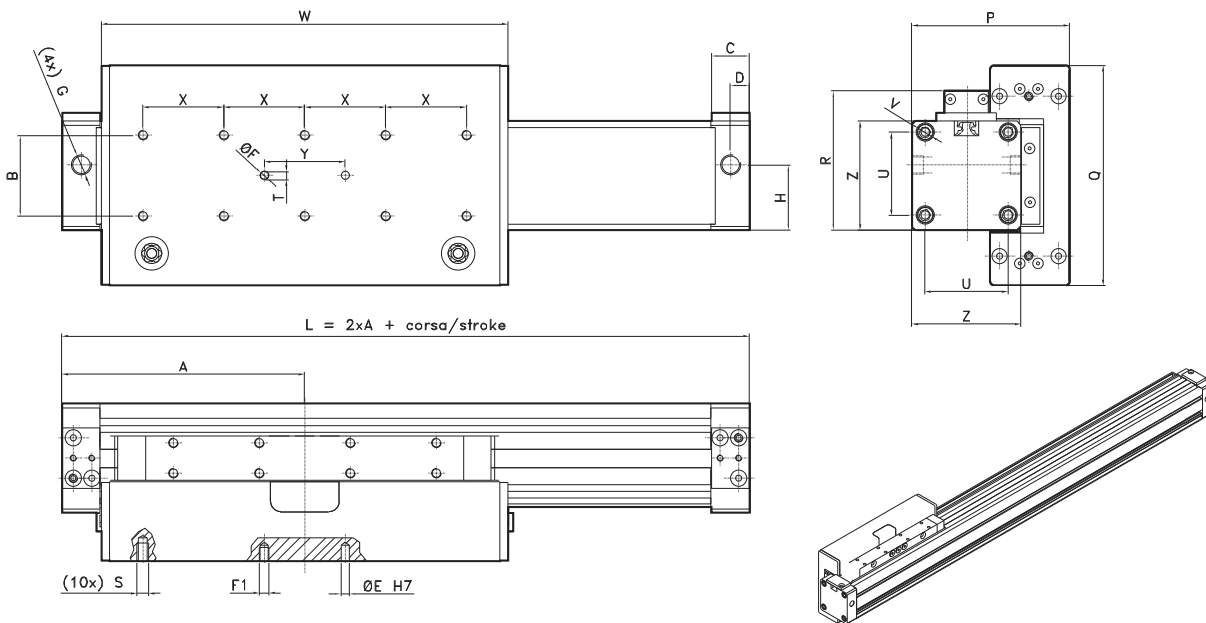

Ø	A	B	C	D	E	F	F1	G	H	P	Q	R	S	T	U	V	Z	X	Y	W
25	100	40	19	9.5	4x8	4x8	4.5x7	G1/8"	25	68	97	60	M5x7.5	4	36	M4x11	45	40	40	160
32	120	40	19	9.5	4x8	4x8	4.5x7	G1/8"	32.5	78	109	69	M6x9	4	41	M5x11	54	40	40	201
40	150	55	23	11.5	6x8	6x8	6.5x7	G1/4"	38	90.5	145	82	M6x12	6	49	M6x12	64	55	40	252
50	175	55	30	17	6x3.5	6x3.5	6.5x3	G3/8"	59	120	164	115	M8x15	6	65	M8x17	90	55	40	270
63	200	70	30	17	6x7	6x7	6.5x6.5	G3/8"	68.5	137	180	132	M8x17	6	78	M8x17	106	70	40	320

STANDARD CON GUIDA A RICIRCOLO DI SFERE CON CONNESSIONI SU UN LATO
STANDARD WITH GUIDA BALL BUSCHINGS WITH CONNECTIONS ON ONE SIDE

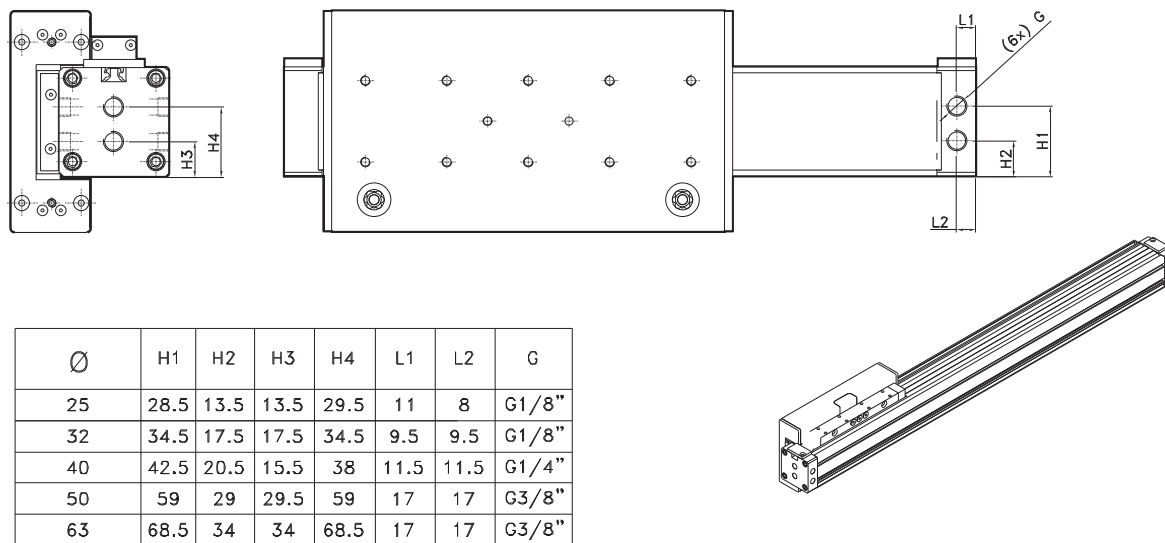

Ø	H1	H2	H3	H4	L1	L2	G
25	28.5	13.5	13.5	29.5	11	8	G1/8"
32	34.5	17.5	17.5	34.5	9.5	9.5	G1/8"
40	42.5	20.5	15.5	38	11.5	11.5	G1/4"
50	59	29	29.5	59	17	17	G3/8"
63	68.5	34	34	68.5	17	17	G3/8"

CORTO CON GUIDA A RICIRCOLO DI SFERE
SHORT WITH GUIDA BALL BUSCHINGS

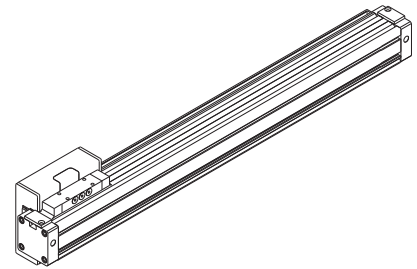
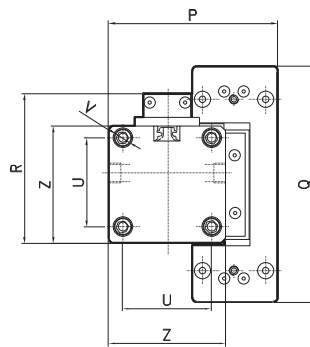
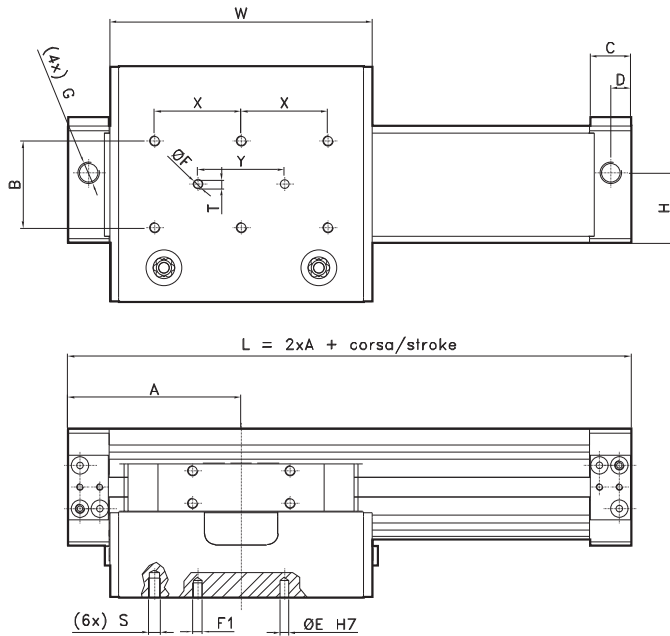

Ø	A	B	C	D	E	F	F1	G	H	P	Q	R	S	T	U	V	Z	X	Y	W
25	67.5	40	19	9.5	4x8	4x8	4.5x7	G1/8"	25	68	97	60	M5x7.5	4	36	M4x11	45	20	40	95
32	77.5	40	19	9.5	4x8	4x8	4.5x7	G1/8"	32.5	78	109	69	M6x9	4	41	M5x11	54	40	40	115
40	95	55	23	11.5	6x8	6x8	6.5x7	G1/4"	38	90.5	145	82	M6x12	6	49	M6x12	64	55	40	143.5
50	105	55	30	17	6x3.5	6x3.5	6.5x3	G3/8"	59	120	164	115	M8x15	6	65	M8x17	90	27.5	40	148
63	125	70	30	17	6x7	6x7	6.5x6.5	G3/8"	68.5	137	180	132	M8x17	6	78	M8x17	106	70	40	188

CORTO CON GUIDA A RICIRCOLO DI SFERE CON CONNESSIONI SU UN LATO
SHORT WITH GUIDA BALL BUSCHINGS WITH CONNECTIONS ON ONE SIDE

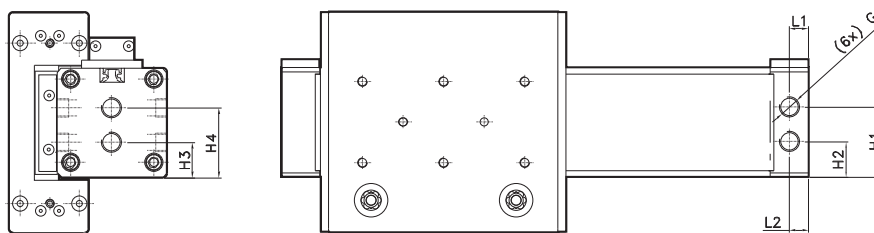

Ø	H1	H2	H3	H4	L1	L2	G
25	28.5	13.5	13.5	29.5	11	8	G1/8"
32	34.5	17.5	17.5	34.5	9.5	9.5	G1/8"
40	42.5	20.5	15.5	38	11.5	11.5	G1/4"
50	59	29	29.5	59	17	17	G3/8"
63	68.5	34	34	68.5	17	17	G3/8"

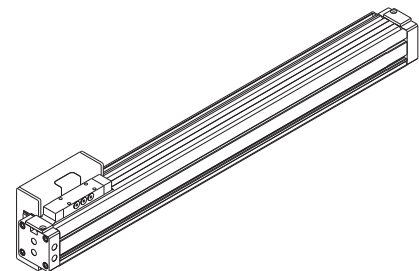

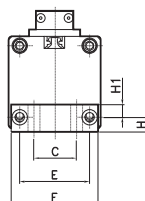
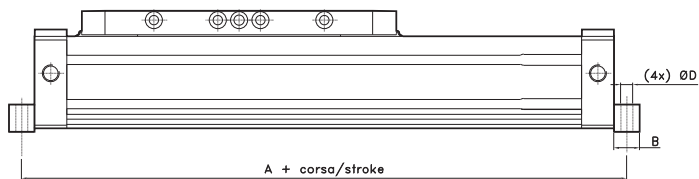

Ø	A	B	C	D	E	F	H	H1
25	210	10	22	5.5	36	45	5.5	4.5
32	255	15	25	7	41	51	8.5	7.5
40	315	15	25	9	49	64	8.5	7.5
50	365	15	40	8.5	65	89	13.5	12.5
63	415	15	50	8.5	78	105	15	14

PIEDINO BASSO / LOW PEDESTAL

CODE	Ø
AR428025	25
AR428032	32
AR428040	40
AR428050	50
AR428063	63

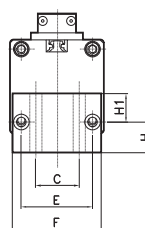
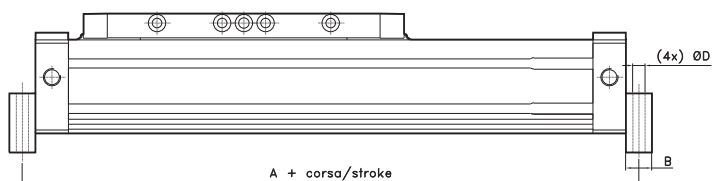

Ø	A	B	C	D	E	F	H	H1
25	215	15	22	5.5	36	45	12.5	5.5
32	255	15	25	7	41	51	17.5	16.5
40	315	15	25	9	49	64	17.5	8.5
50	365	15	40	8.5	65	89	27.5	12.5
63	415	15	50	8.5	78	105	29	11

PIEDINO ALTO / HIGH PEDESTAL

CODE	Ø
AR428125	25
AR428132	32
AR428140	40
AR428150	50
AR428163	63

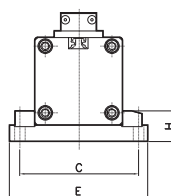
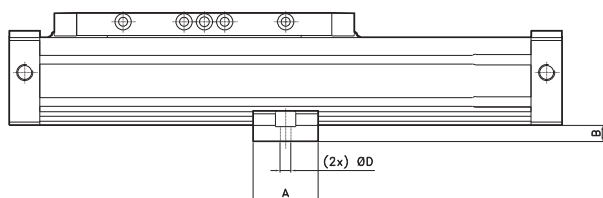

Ø	A	B	C	D	E	H
25	35	8	60	5.5	70	18.5
32	40	10	73	6.5	85	18.5
40	40	10	90.5	9	105	18.5
50	70	15	120	11	138	30
63	70	15	136	11	154	36

SUPPORTO INTERMEDIO /
INTERMEDIATE SUPPORT

CODE	Ø
AR428225	25
AR428232	32
AR428240	40
AR428250	50
AR428263	63

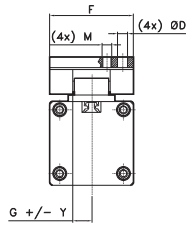
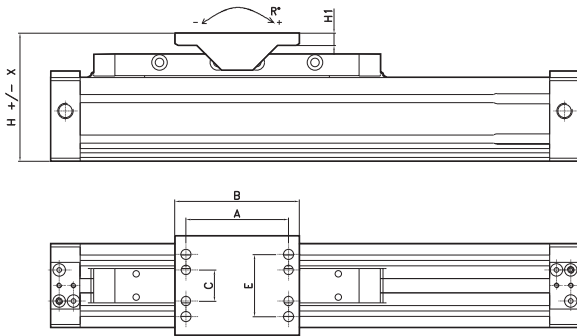

Ø	A	B	C	D	E	F	G	Y	H	X	H1	M	R
25	66	80	20	6.5	40	54	12	0.8	74	1	8	M6	8
32	66	80	20	6.5	40	54	12	0.8	82	0.5	8	M6	6
40	66	80	20	6.5	40	54	12	0.8	94.5	0.5	8	M6	6
50	102	122	23	9	51	80	24	0.8	130.5	0.5	11	M8	5
63	102	122	23	9	51	80	24	0.8	146	0.5	11	M8	4.5

CERNIERA OSCILLANTE LARGA /
LARGE SWINGING BRIDGE

CODE	Ø
AR428325	25
AR428332	32
AR428340	40
AR428350	50
AR428363	63

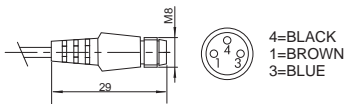
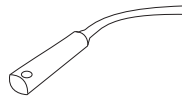
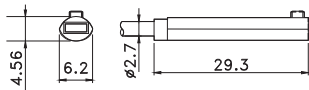

SENSORE OVALE
OVAL SWITCH

CODE	
AR4019010	REED (MT.2,5) / REED (MT.2,5)
AR4019020	HALL (MT.2,5) / HALL (MT.2,5)
AR4019110	REED + M8 (CM 30) / REED + M8
AR4019120	HALL + M8 (CM 30) / HALL + M8

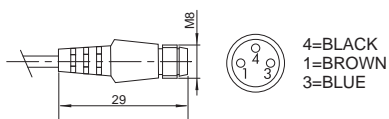
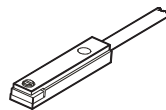
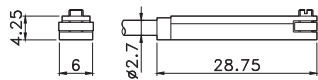

SENSORE A T
T SWITCH

CODE	
AR4023010	REED (MT.2,5) / REED (MT.2,5)
AR4023020	HALL (MT.2,5) / HALL (MT.2,5)
AR4023110	REED + M8 (CM 30) / REED + M8
AR4023120	HALL + M8 (CM 30) / HALL + M8

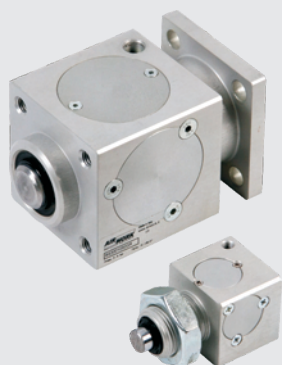

Il bloccastelo brevettato AW è un dispositivo meccanico da applicare ai cilindri ISO 15552 e 6432 VDMA il cui scopo è quello di bloccare lo stelo dei cilindri in qualsiasi posizione. Questa soluzione permette di bloccare la corsa del cilindro in qualsiasi momento si verifichi un'improvvisa caduta di pressione. La forza di bloccaggio è sempre e comunque maggiore di quella sviluppata dal rispettivo cilindro alimentato a 10 bar.

The patented AIRWORK ROD LOCK BS series is a mechanical device designed to be used with all ISO 15552 and 6432 VDMA cylinders, and which purpose is to block the rod of the cylinder in any position. This solution allows to block the stroke of the cylinder every time an unexpected fall of pressure takes place. The blocking force is always bigger than the one developed from the corresponding cylinder at 10 bars.

CHIAVE DI CODIFICA / KEY TO TYPE NUMBER

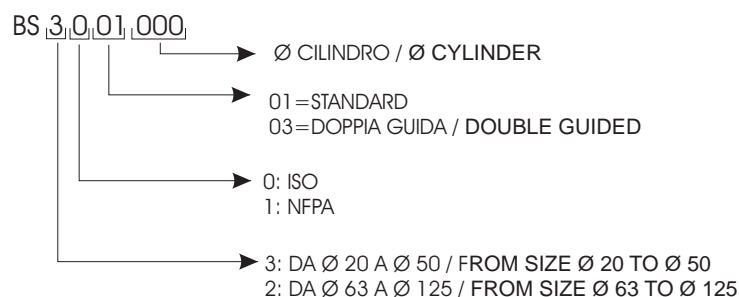

DATI TECNICI / TECHNICAL DATA

Taglie / Sizes	Ø20-25-32-40-50-63-80-100-125
Fluido / Fluid	Aria con o senza lubrificazione / Lubricated or non lubricated air
Pressione di funzionamento / Operating pressure	3 - 6 bar
Temperature di funzionamento / Temperature range	-5°C / +80°C
Tipo di bloccaggio / Type of locking	Meccanico bidirezionale / Mechanical bi-directional
In assenza di pressione / In absence of pressure	Bloccato / Locked
Forza di bloccaggio / Locking forces	(Ø20=490N) (Ø25=490N) (Ø32=790N) (Ø40=1240N) (Ø50=1930N) (Ø63=3060N) (Ø80=5400N) (Ø100=7700N) (Ø125=12040N)

ATTENZIONE

Il funzionamento del bloccastelo Air Work è di tipo statico (stelo cilindro non in movimento). E' necessario arrestare lo stelo del cilindro prima di effettuare il bloccaggio.

ATTENTION

Air Work rod lock's functioning is of static type (cylinder's rod must be stopped). It is necessary to stop the cylinder's rod before making the lock.

COMPONENTI / COMPONENTS

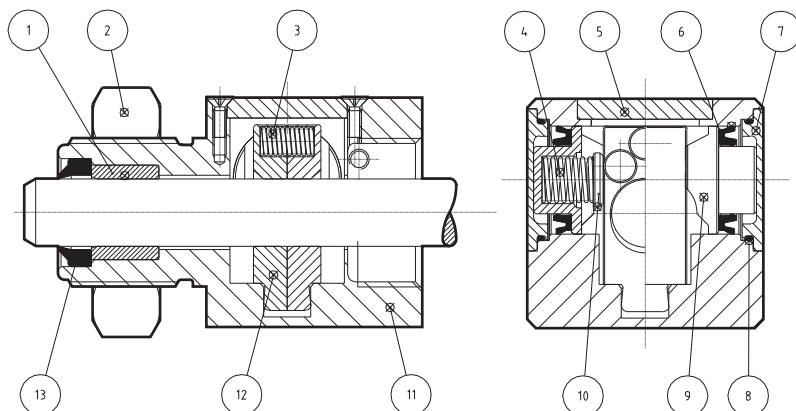

pos.	descrizione / description	materiale / material
1	bussola guida / guide bush	Delring
2	dado / nut	acciaio / steel
3	molla / spring	acciaio / steel
4	molla / spring	acciaio / steel
5	coperchio / cover	alluminio / aluminium
6	guarn.pistone / piston seal	NBR
7	coperchio / cover	alluminio / aluminium
8	o-ring	NBR
9	pistone / piston	Delring
10	disco molla / spring cover	Delring
11	corpo / body	alluminio / aluminium
12	palette / jaws	bronzo / bronze
13	guarn.stelo / rod seal	NBR

SCHEMA DI COLLEGAMENTO / CONNECTION SCHEME

COMANDO PNEUMATICO
PNEUMATIC CONTROL

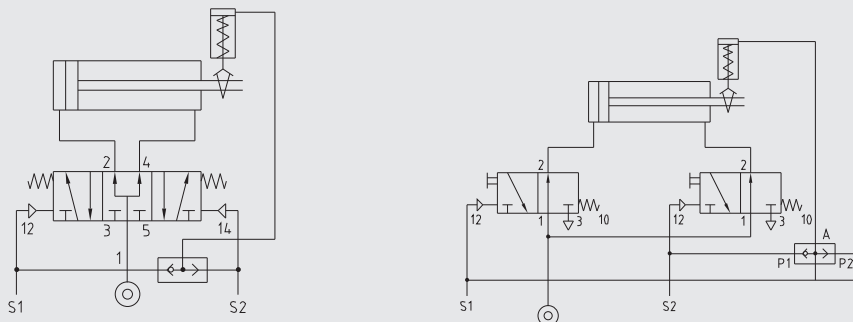

COMANDO
ELETTROPNEUMATICO

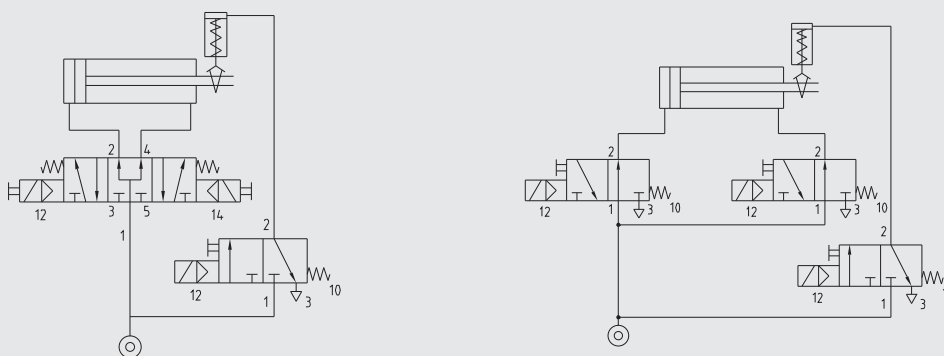

MONTAGGIO SUL CILINDRO / INSTALLATION ON THE CYLINDER

Attenzione: non togliere l'alimentazione dell'aria in assenza del pezzo di stelo o dello stelo del cilindro.

Attention: don't remove air feeding in absence of the piece of rod or of cylinder rod.

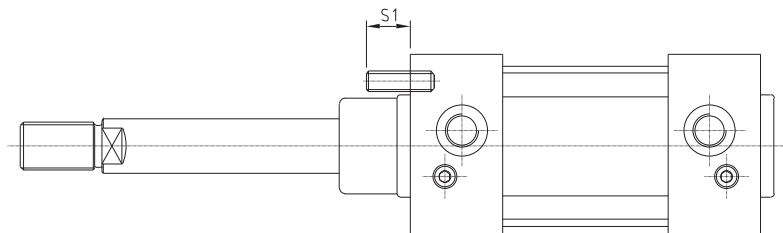

CILINDRO ϕ	32	40	50	63	80	100	125
S1	12	12	16	16	22	22	32

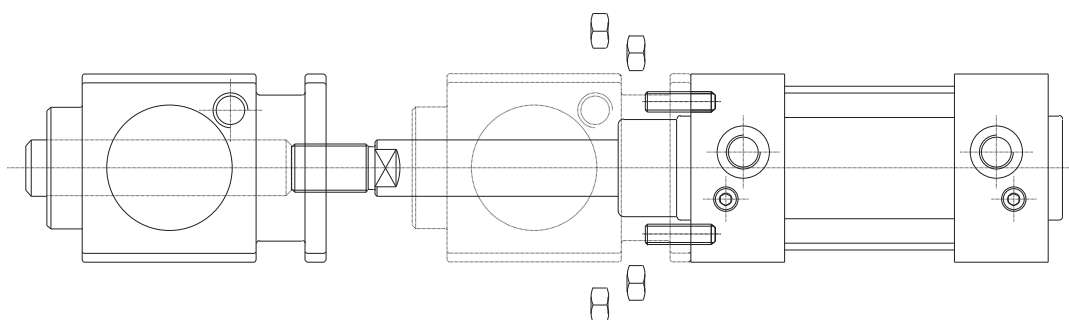

BLOCCASTELO PER CILINDRI ISO 6432
ROD LOCK FOR CYLINDERS ISO 6432

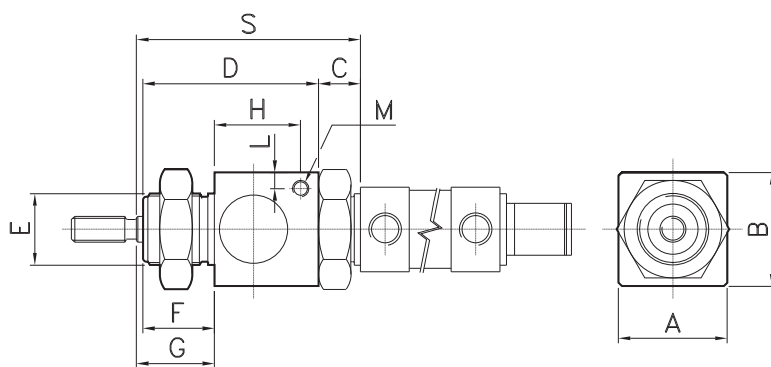

Ø	A	B	C	D	E	F	G	H	L	M	S	T	Peso in Kg. weight in Kg.
20	34	35	13	54	M22x1.5	22	26	27	5	M5	71	47	0.190
25	34	35	13	54	M22x1.5	22	28	27	5	M5	73	45	0.190

PER ASSEMBLARE IL BLOCCASTELO AL CILINDRO SI DEVE COSTRUIRE LO STELO MAGGIORATO DELLA QUOTA "T"
TO ASSEMBLE THE ROD LOCK ON THE CYLINDER, IT IS ESSENTIAL TO INCREASE THE ROD LENGTH, AS QUOTED
IN THE TABLE OF DIMENSION "T"

BLOCCASTELO PER CILINDRI ISO 15552
ROD LOCK FOR CYLINDERS ISO 15552

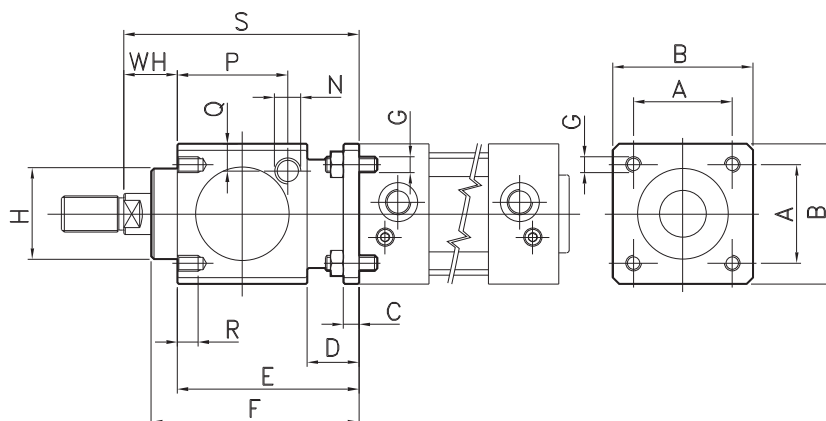

Ø	A	B	C	D	E	F	G	H	WH	N	P	Q	R	S	T	Peso in Kg. Weight in Kg.
32	32.5	47	6	20	60	67.5	M6	30	26	1/8"G	33.25	9	8	86	60	0.400
40	38	54	6	20	70	80	M6	34.9	30	1/8"G	42.5	9	8	100	70	0.600
50	46.5	65	8	24	90	100	M8	40	37	1/8"G	58	12.5	12	127	90	1.100
63	56.5	75	8	24	90	100	M8	45	37	1/8"G	59	17.5	12	127	90	1.500
80	72	95	12	32	110	120	M10	45	46	1/4"G	69	17.5	16	156	110	2.600
100	89	114	12	32	110	120	M10	55	51	1/4"G	69	20	16	161	110	3.500
125	110	138	20	45	140	156	M12	60	65	1/4"G	84.5	19	20	205	140	6.500

PER ASSEMBLARE IL BLOCCASTELO AL CILINDRO SI DEVE COSTRUIRE LO STELO MAGGIORATO DELLA QUOTA "T"
TO ASSEMBLE THE ROD LOCK ON THE CYLINDER, IT IS ESSENTIAL TO INCREASE THE ROD LENGTH, AS QUOTED
IN THE TABLE OF DIMENSION "T"

BLOCCASTELO CON DOPPIA GUIDA PER MONTAGGIO SENZA CILINDRO
ROD LOCK WITH DOUBLE GUIDE FOR MONTING WITHOUT CYLINDER

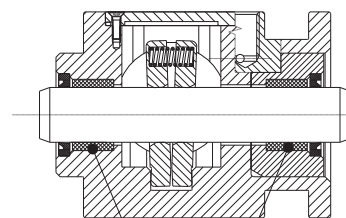
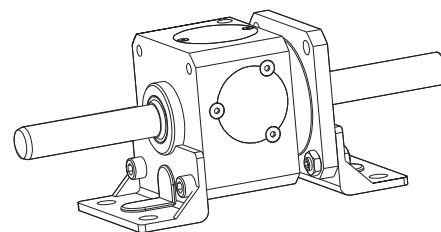
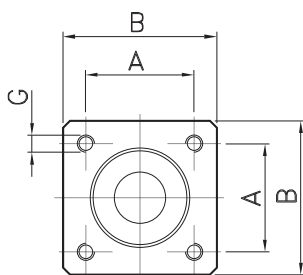
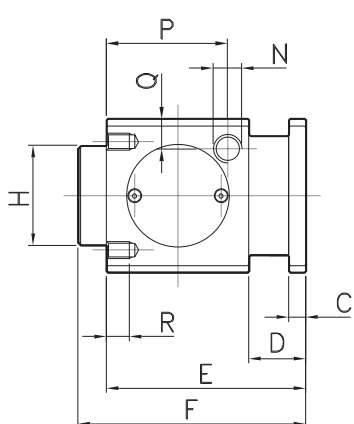

DOPPIA GUIDA STELO
DOUBLE GUIDE ROD

Ø	A	B	C	D	E	F	G	H	N	P	Q	R	T	Peso in Kg. Weight in Kg.
32	32.5	47	6	20	60	67.5	M6	30	1/8"G	33.25	9	8	60	0.400
40	38	54	6	20	70	80	M6	34.9	1/8"G	42.5	9	8	70	0.600
50	46.5	65	8	24	90	100	M8	40	1/8"G	58	12.5	12	90	1.100
63	56.5	75	8	24	90	100	M8	45	1/8"G	59	17.5	12	90	1.500
80	72	95	12	32	110	120	M10	45	1/4"G	69	17.5	16	110	2.600
100	89	114	12	32	110	120	M10	55	1/4"G	69	20	16	110	3.500
125	110	138	20	45	140	156	M12	60	1/4"G	84.5	19	20	140	6.500

BLOCCASTELO VERSIONE NFPA
ROD LOCK NFPA VERSION

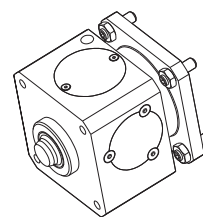
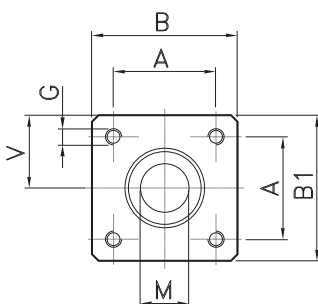
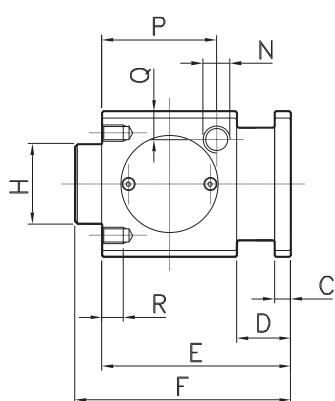

Ø	A	B	B1	C	D	E	F	G	H	M	N	P	Q	R	T	V	Peso in Kg. Weight in Kg.
1.5"	36.32	50.8	49.6	6	20	70	80	1/4-28UNF	28.6	5/8"	1/8"NPTF	43	7.4	9	70	25.4	0.520
2"	46.74	63.5	62.2	8	24	90	100	5/16-24UNF	28.6	5/8"	1/8"NPTF	58	11.8	14	90	31.1	1.000
2.5"	55.63	75	75	8	24	90	100	5/16-24UNF	28.6	5/8"	1/8"NPTF	59	17.5	14	90	37.5	1.500
3.25"	70.1	95	94	12	32	110	120	3/8-24UNF	38.1	1"	1/4"NPTF	69	17.5	16	110	47	2.500
4"	84.33	114	113	12	32	110	120	3/8-24UNF	38.1	1"	1/4"NPTF	69	20	16	110	56.5	3.300
5"	104.14	138	138	20	45	140	150	1/2-20UNF	38.1	1"	1/4"NPTF	84.5	19	21	140	69	6.300

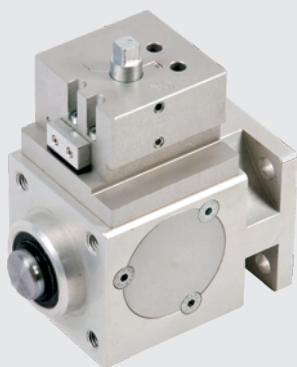

Il bloccastele brevettato AW è un dispositivo meccanico da applicare ai cilindri ISO 15552 e 6432 VDMA il cui scopo è quello di bloccare lo stelo dei cilindri in qualsiasi posizione. Questa soluzione permette di bloccare la corsa del cilindro in qualsiasi momento si verifichi un'improvvisa caduta di pressione. La forza di bloccaggio è sempre e comunque maggiore di quella sviluppata dal rispettivo cilindro alimentato a 10 bar.

The patented AIRWORK ROD LOCK BM series is a mechanical device to apply to cylinders ISO 15552 and 6432 VDMA whose scope is to block cylinder's rod, in any position. This solution allows to block the race of the cylinder anytime takes place an unexpected fall of pressure. The blocking force is always and however greater of the one developed from the respective cylinder at 10 bars.

CHIAVE DI CODIFICA / KEY TO TYPE NUMBER

BS2002_000



DATI TECNICI / TECHNICAL DATA

Taglie / Sizes	Ø32-40-50-63-80-100
Fluido / Fluid	Aria con o senza lubrificazione / Lubricated or non lubricated air
Pressione di funzionamento / Operating pressure	3 - 6 bar
Temperature di funzionamento / Temperature range	-5C° / +80C°
Tipo di bloccaggio / Type of locking	Meccanico bidirezionale / Mechanical bi-directional
In assenza di pressione / In absence of pressure	Bloccato / Locked
Forza di bloccaggio / Locking forces	(Ø32=790N) (Ø40=1240N) (Ø50=1930N) (Ø63=3060N) (Ø80=5400N) (Ø100=7700N)

ATTENZIONE

Il funzionamento del bloccastele Air Work è di tipo statico (stelo cilindro non in movimento). E' necessario arrestare lo stelo del cilindro prima di effettuare il bloccaggio.

ATTENTION

Air Work rod lock's functioning is static type (cylinder's rod stopped). Before using the brake, take care to stop cylinder's rod.

COMPONENTI / COMPONENTS

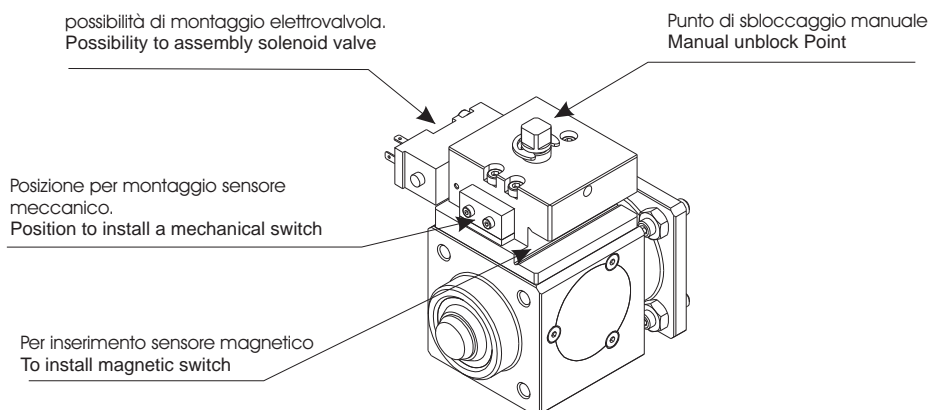
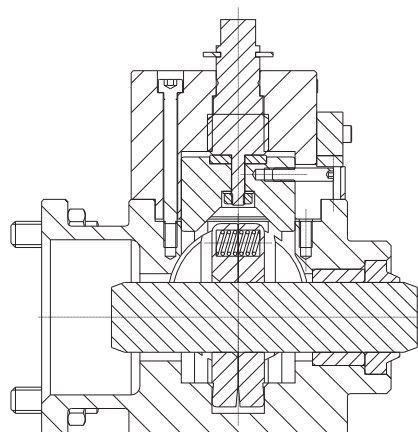

SCHEMA DI COLLEGAMENTO / CONNECTION SCHEME

COMANDO PNEUMATICO
PNEUMATIC CONTROL

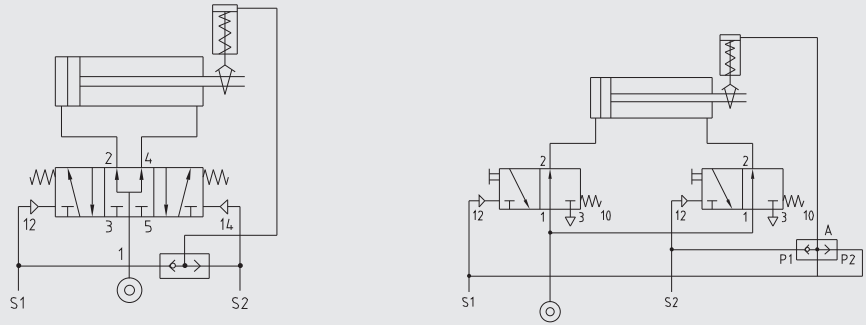

COMANDO ELETTROPNEUMATICO
ELECTROPNEUMATIC CONTROL

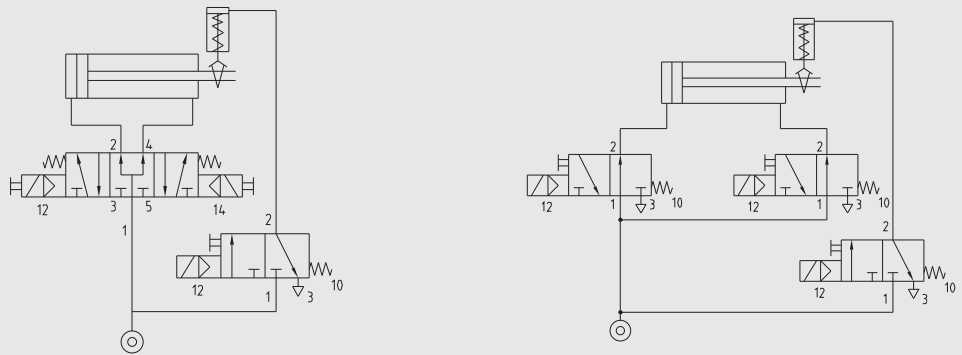

MONTAGGIO SUL CILINDRO / INSTALLATION ON THE CYLINDER

Attenzione: non togliere l'alimentazione dell'aria in assenza del pezzo di stelo o dello stelo del cilindro.

Attention: don't remove air feeding in absence of the piece of rod or of cylinder rod.

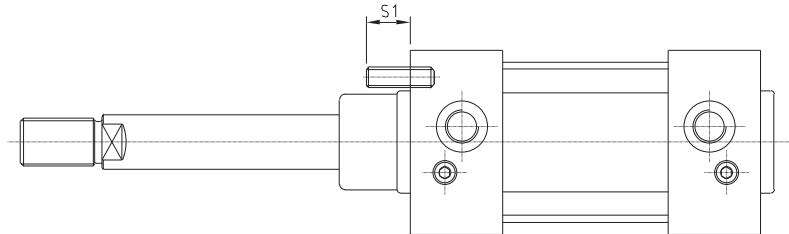

CILINDRO ϕ	32	40	50	63	80	100	125
S1	12	12	16	16	22	22	32

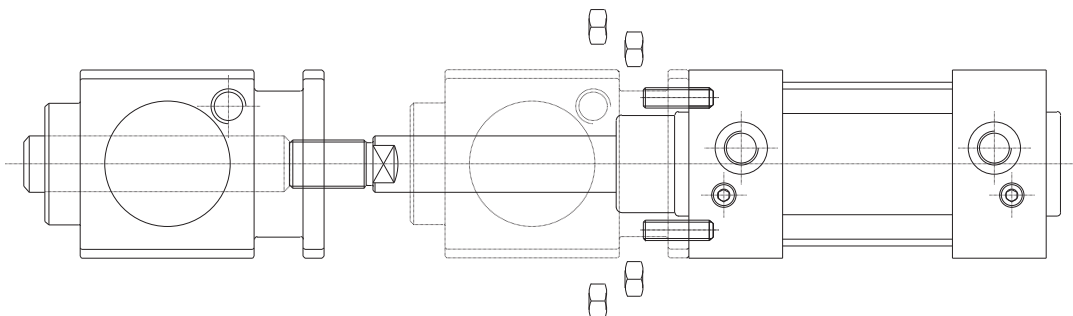

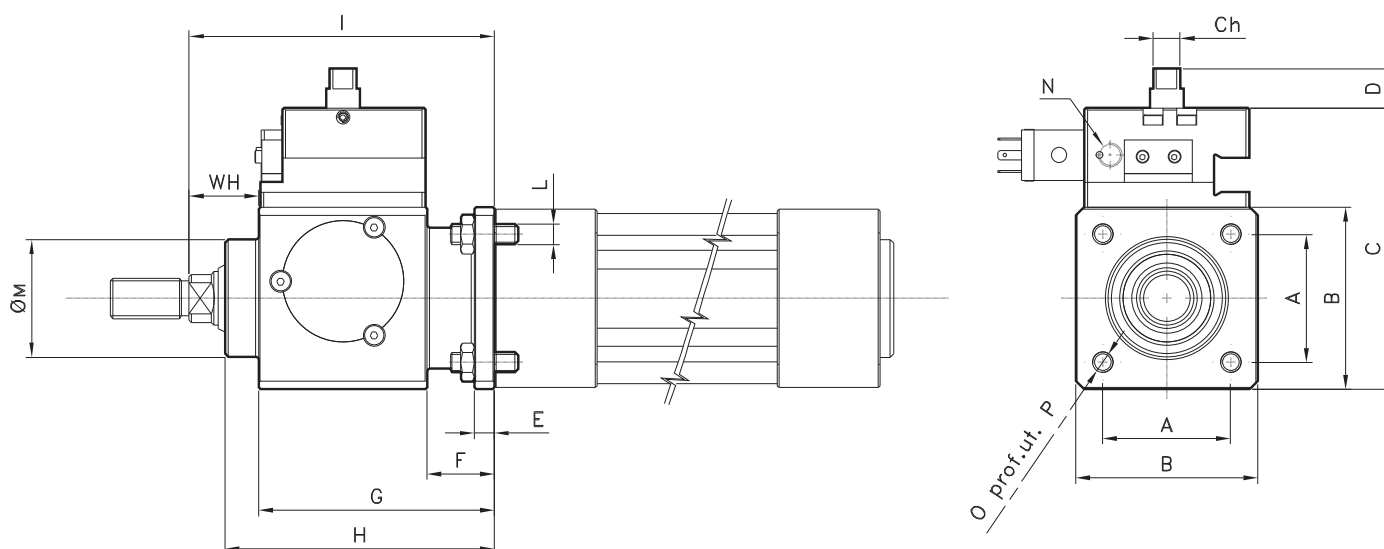
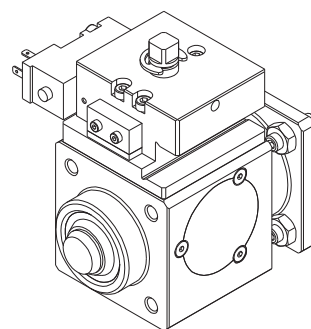

Ø	A	B	C	D	E	F	G	H	I	L	M	N	O	P	T	WH	Ch
32	32.5	47	79.5	11	6	20	60	67.5	86	M6	30	1/8"G	M6	8	60	26	8
40	38	54	85	11	6	20	70	80	100	M6	34.9	1/8"G	M6	8	70	30	8
50	46.5	65	107	14	8	24	90	100	127	M8	40	1/8"G	M8	12	90	37	8
63	56.5	75	113	14	8	24	90	100	127	M8	45	1/8"G	M8	12	90	37	8
80	72	95	138.5	25	12	32	110	120	156	M10	45	1/4"G	M10	16	110	46	8
100	89	114	155	25	12	32	110	120	161	M10	55	1/4"G	M10	16	110	51	8

PER ASSEMBLARE IL BLOCCASTELO AL CILINDRO, SI DEVE COSTRUIRE LO STELO MAGGIORATO DELLA QUOTA "T"
TO ASSEMBLE ROD LOCK AND CYLINDER, IS NECESSARY TO BUILD THE ROD INCREASED OF QUOTE "T"

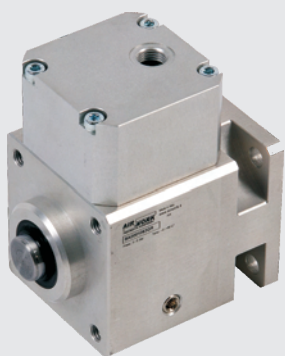

Il bloccatelo della serie BA è un dispositivo capace di bloccare lo stelo durante la corsa del cilindro e di tenerlo fermo anche in presenza di pressione nel cilindro.
La speciale caratteristica di questa versione è l'assoluta assenza di movimento assiale e rotatorio dello stelo e la perfetta adattabilità alle diverse tolleranze degli steli dei cilindri.

The rod lock of the BA series is a device made to stop the rod during the run of the cylinder and to keep it locked even when there is pressure in the cylinder.
The special characteristic of this version is the absolute absence of axial and rotary movement of the rod and the perfect adaptability to the different tolerances of cylinders rods.

CHIAVE DI CODIFICA / KEY TO TYPE NUMBER

BA00 01 000

- Ø CILINDRO / Ø CYLINDER
- 01 = STANDARD
- 03 = DOPPIA GUIDA PER MONTAGGIO SENZA CILINDRO
DOUBLE GUIDED FOR MOUNTING WITHOUT CYLINDER

DATI TECNICI / TECHNICAL DATA

Taglie / Sizes	Ø 63 - 80 - 100 - 125
Fluido / Fluid	Aria con o senza lubrificazione / Lubricated or non lubricated air
Pressione di funzionamento / Operating pressure	3 - 10 bar
Temperature di funzionamento / Temperature range	-5°C / +80°C
Tipo di bloccaggio / Type of locking	Meccanico bidirezionale / Mechanical bi-directional
In assenza di pressione / In absence of pressure	Bloccato / Locked
Forza di bloccaggio / Locking forces	(Ø63=3060N) (Ø80=5400N) (Ø100=7700N) (Ø125=12040N)

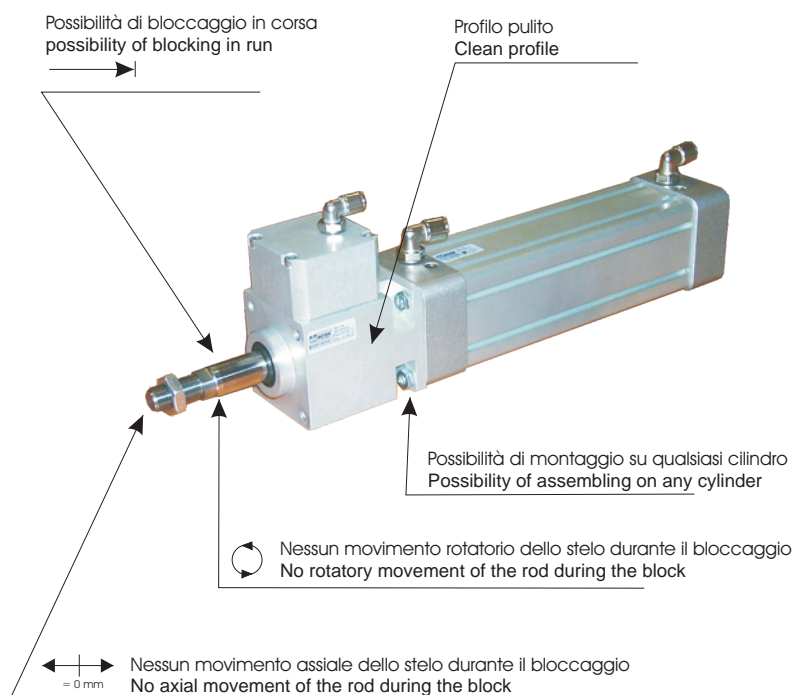

**SCHEMA DI COLLEGAMENTO
CONNECTION SCHEME**

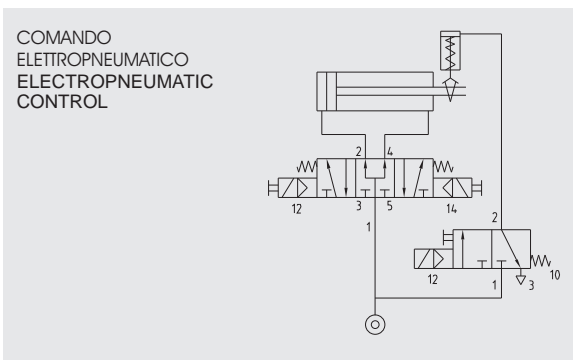
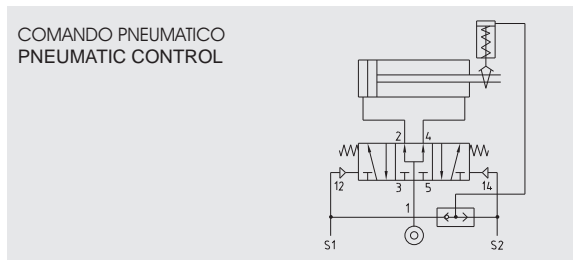

VERSIONE STANDARD
STANDARD VERSION

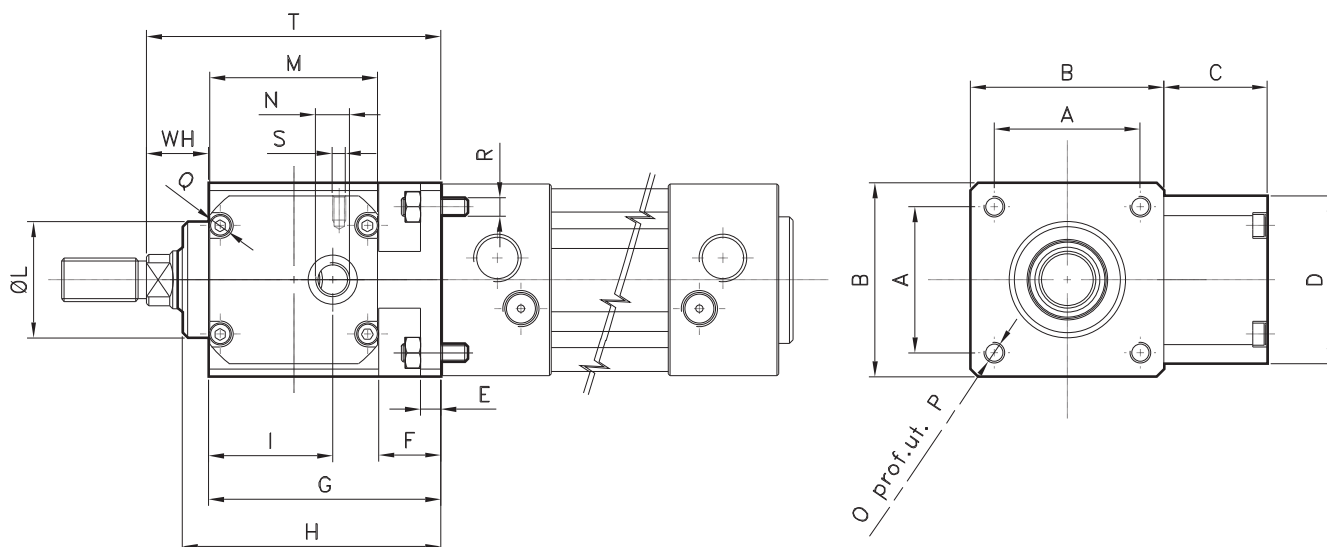

Ø	A	B	C	D	E	F	G	H	I	L	M	N	O	P	Q	R	S	T	V	WH
63	56.5	75	40	70	8	22	92	100	50	45	70	1/4"G	M8	12	M5	M8	M5	127	90	37
80	72	95	50	85	12	32	120	130	59	45	85	1/4"G	M10	16	M6	M10	M5	166	120	46
100	89	114	65	105	12	32	140	130	69	55	105	1/4"G	M10	16	M8	M10	/	191	120	51
125	110	138	80	130	20	45	180	196	87,5	60	130	1/4"G	M12	20	M10	M12	1/8"G	245	180	65

PER ASSEMBLARE IL BLOCCASTELO AL CILINDRO SI DEVE COSTRUIRE LO STELO MAGGIORATO DELLA QUOTA "V"
TO ASSEMBLE THE ROD LOCK ON THE CYLINDER, IT IS ESSENTIAL TO INCREASE THE ROD LENGTH, AS QUOTED
IN THE TABLE OF DIMENSION "V"

VERSIONE DOPPIA GUIDA
PER MONTAGGIO SENZA CILINDRO
DOUBLE GUIDE VERSION
FOR MOUNTING WITHOUT
CYLINDER

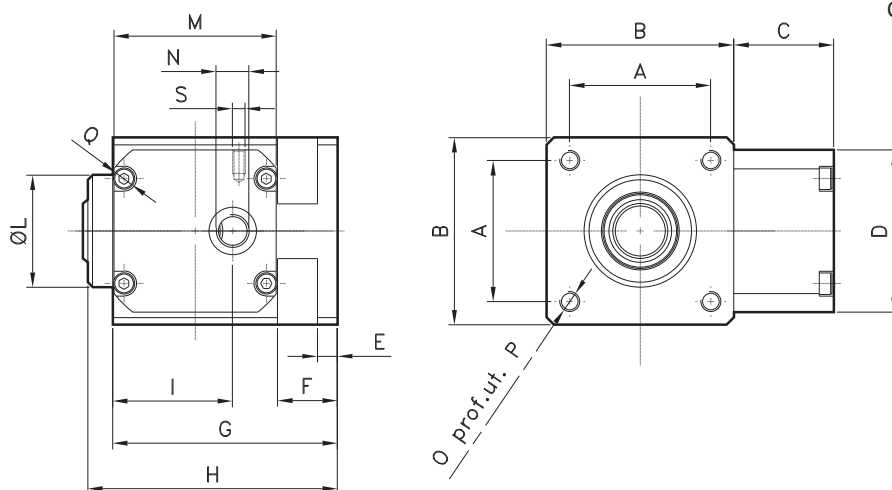

Ø	A	B	C	D	E	F	G	H	I	L	M	N	O	P	Q	R	S
63	56.5	75	40	70	8	22	92	100	50	45	70	1/4"G	M8	12	M5	M8	M5
80	72	95	50	85	12	32	120	130	59	45	85	1/4"G	M10	16	M6	M10	M5
100	89	114	65	105	12	32	140	130	69	55	105	1/4"G	M10	16	M8	M10	/
125	110	138	80	130	20	45	180	196	45	87,5	130	1/4"G	M12	20	M10	M12	1/8"G



I cilindri stopper hanno lo scopo di arrestare o bloccare parti in movimento come carichi di una linea di montaggio oppure come blocco di stazionamento, sfruttando il grande diametro dello stelo utilizzandolo come perno.

The stopper cylinders are made to stop or block moving parts such as load on an assembly line; they can also work as stand-by stopping device, since they exploit the large diameter of the rod using it as a pivot.

CHIAVE DI CODIFICA / KEY TO TYPE NUMBER

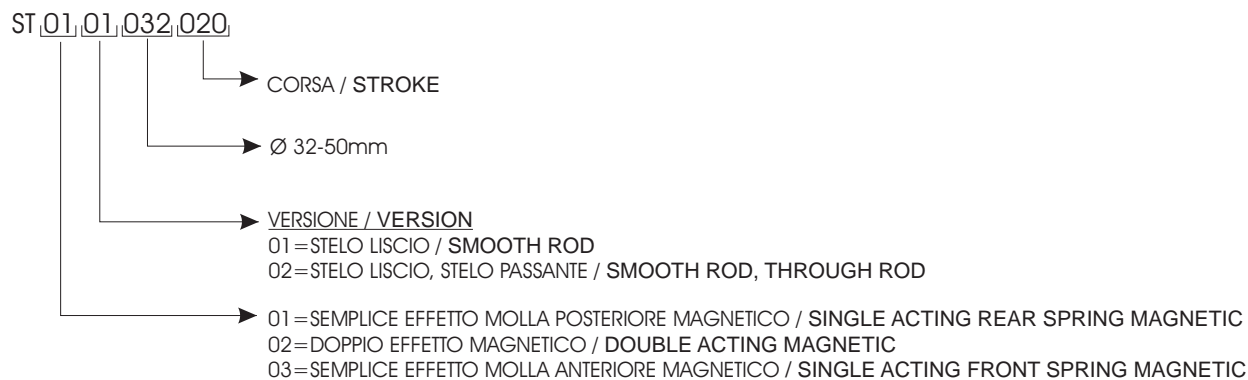

DATI TECNICI / TECHNICAL DATA

Alesaggi - Sizes	Ø32-50
Corse standard - Standard strokes	Ø32x20 Ø50x30
Fluido - Fluid	Aria con o senza lubrificazione - Lubricated or not lubricated air
Temperatura di esercizio - Operating temperature range	-20C° / +80C°
Pressione massima di esercizio - Max operating pressure	10 bar
Forze sviluppate - Force	pag. dati tecnici / technical informations page
Consumo aria - Air consumption	pag. dati tecnici / technical informations page

DIAGRAMMA DI CARICO / LOAD GRAFH

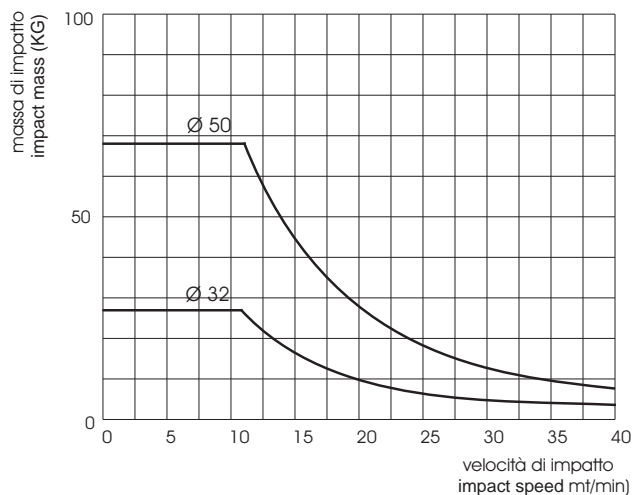

Ø32mm

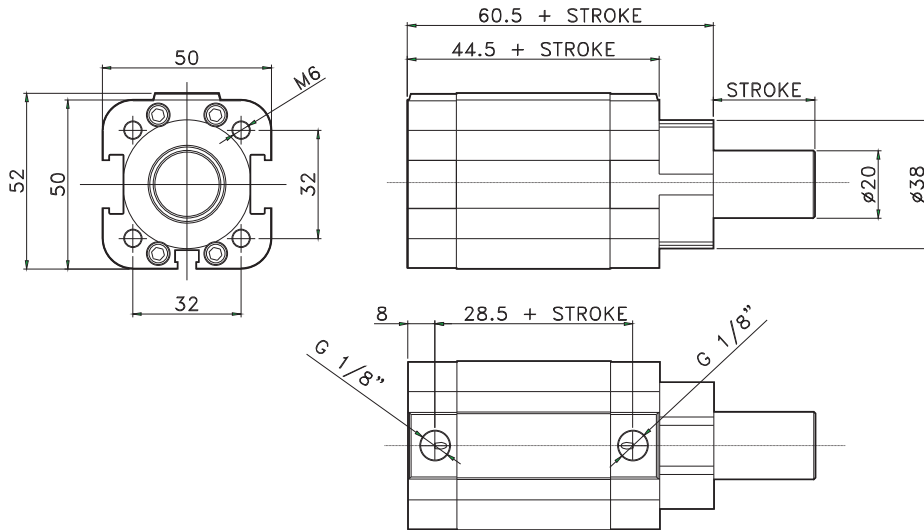
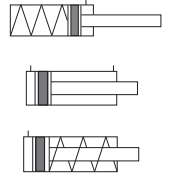

Ø32mm

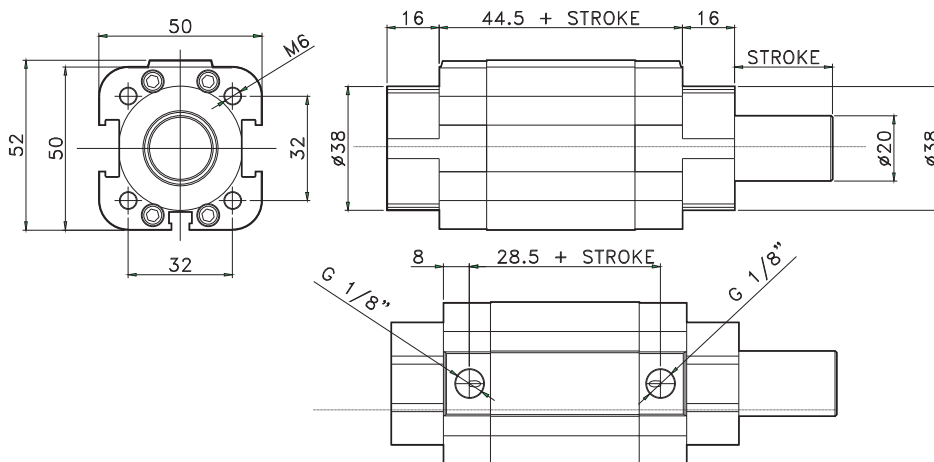
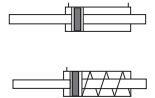

Ø50mm

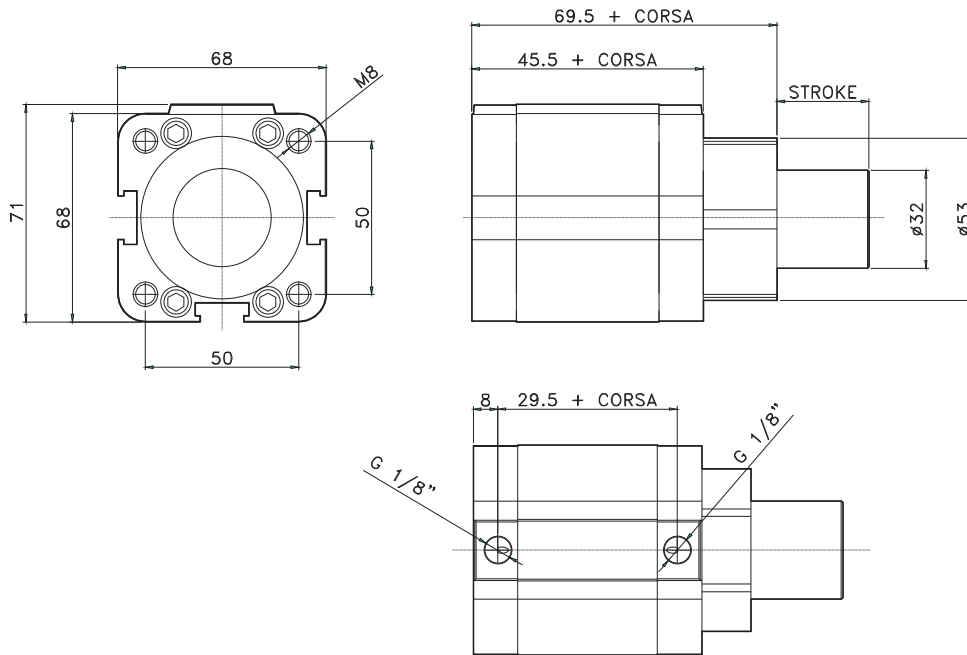
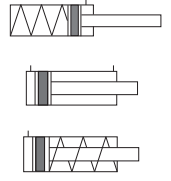

Ø50mm

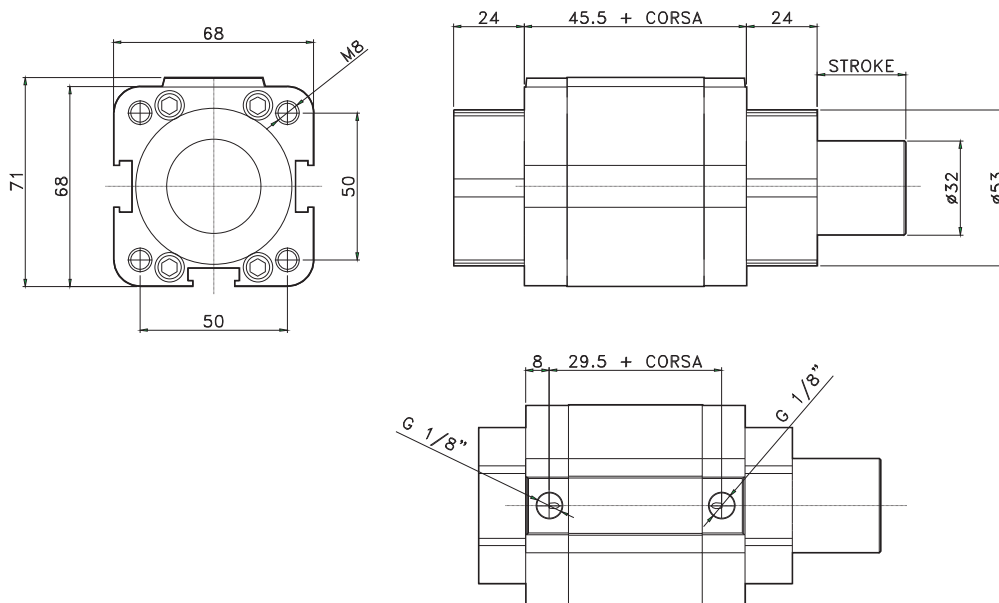
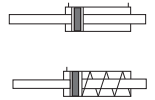

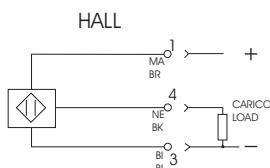
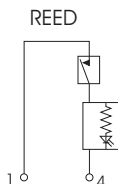
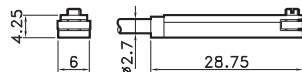
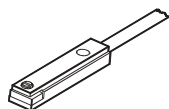

SENSORE A T
"T" SWITCH
CODE

AR4023010	REED 2 FILI (MT.2,5) / REED WITH 2 WIRES (MT.2,5)
AR4023020	HALL 3 FILI (MT.2,5) / HALL WITH 3 WIRES (MT.2,5)
AR4023110	REED 2 FILI + M8 (CM 30) / REED WITH 2 WIRES WITH M8
AR4023120	HALL 3 FILI + M8 (CM 30) / HALL WITH 3 WIRES WITH M8

DATI TECNICI / TECHNICAL DATA

Grado di protezione / Protection class	IP 67 EN 60529
Temp. di impiego / Working temp.	-20C° +85C°
Materiale custodia / Housing material	PA
Tensione in DC / Tension in DC	Reed 3-30V / Hall 6-30V
Tensione in AC / Tension in AC	Reed 3-30V
Corrente a 25 C° / Current at 25 C°	Reed 0,20A / Hall 0,20A
Tempo inserzione / On time	Reed 0,5mS / Hall 0,8 uS
Tempo disinserzione / Off time	Reed 0,1mS / Hall 0,3 uS

Materiale: Alluminio
Material: Aluminium



ADATTATORE PER SENSORE
ADAPTER FOR SWITCH

CODE	Ø
AR4027000	32-50

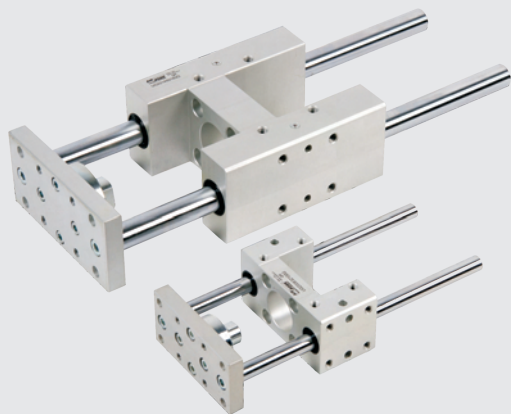

Le unità di guida AW sono accessori per cilindri a norme ISO 15552 e 6432 VDMA. Sono utilizzate per spostamenti di carichi importanti abbinati ad elevata velocità ed a precisione di posizionamento. Queste caratteristiche permettono impieghi diversi sia nel campo del caricamento delle macchine utensili, sia nel settore dell'imballaggio che in quello della manipolazione in genere.

AIRWORK'S guide unit H type are engineered for cylinders complying with ISO 15552 and 6432 VDMA norms. They are recommended for the displacement of high loads and where also high speed and precision of positioning are requested. These characteristics renders this guide unit suitable for use in several industrial fields, like in loading lines, in the packaging industry and the automation in general.

CHIAVE DI CODIFICA / KEY TO TYPE NUMBER

UG 2 0 0 4 000 000

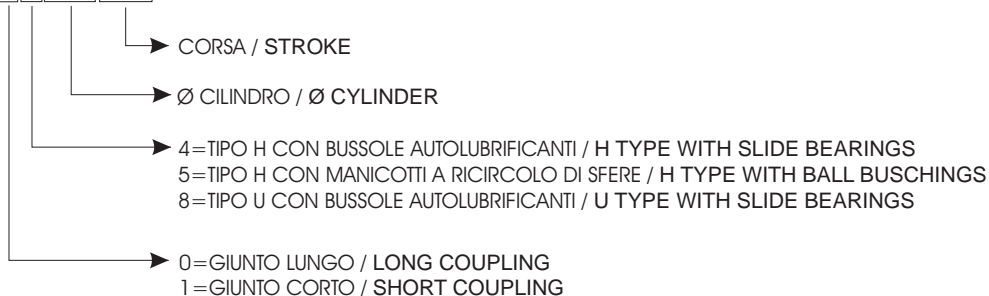

CORSE STANDARD - STANDARD STROKES

Ø16	mm 50-100-160-200-250-320-400-500
Ø20	mm 50-100-160-200-250-320-400-500
Ø25	mm 50-100-160-200-250-320-400-500
Ø32	mm 50-100-160-200-250-320-400-500
Ø40	mm 50-100-160-200-250-320-400-500
Ø50	mm 50-100-160-200-250-320-400-500
Ø63	mm 50-100-160-200-250-320-400-500
Ø80	mm 50-100-160-200-250-320-400-500
Ø100	mm 50-100-160-200-250-320-400-500

COMPONENTI / COMPONENTS

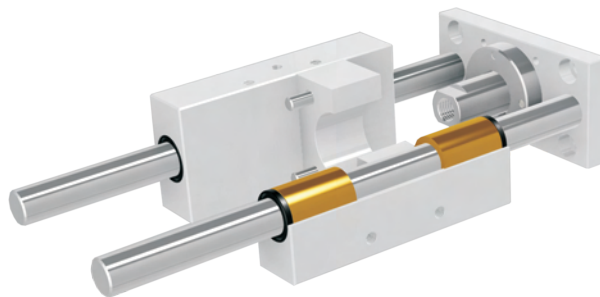
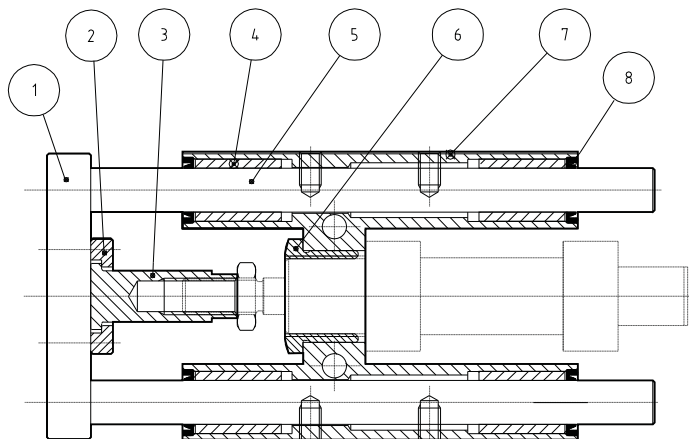

pos.	descrizione / description	materiale / material
1	piastra / plate	alluminio / aluminium
2	ghiera / metal ring	acciaio / steel
3	bussola stelo / bush for rod	acciaio / steel
4	bussola guida / slide bearing	bronzo / bronze
5	man.a sfera / ball busching	acciaio / steel
6	ghiera / metal ring	acciaio / steel
7	corpo / body	alluminio / aluminium
8	guarn.stelo / rod seal	NBR

CARICHI MASSIMI AMMISSIBILI IN FUNZIONE DELLA CORSA / MAXIMUM ALLOWABLE LOADS IN RELATION TO THE STROKE

TIPO H CON BUSSOLE IN BRONZO
H TYPE WITH SLIDE BEARINGS

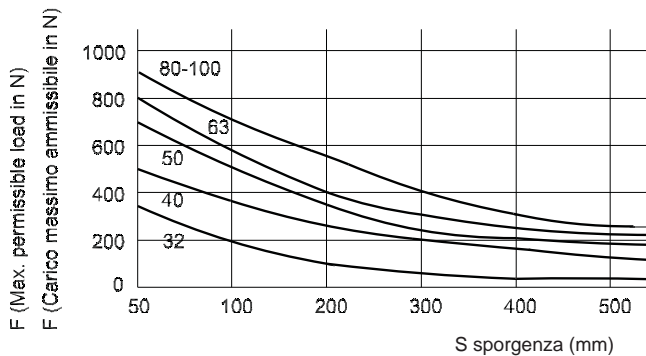
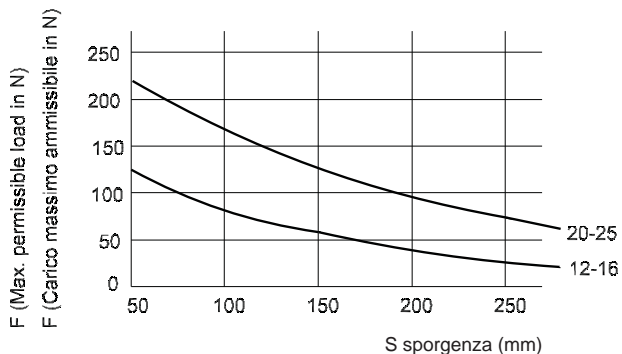
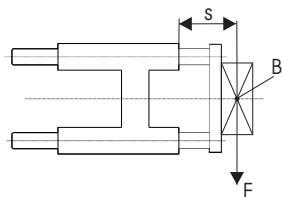

TIPO H CON CUSCINETTI A RICIRCOLO DI SFERE
H TYPE WITH BALL BUSCHINGS

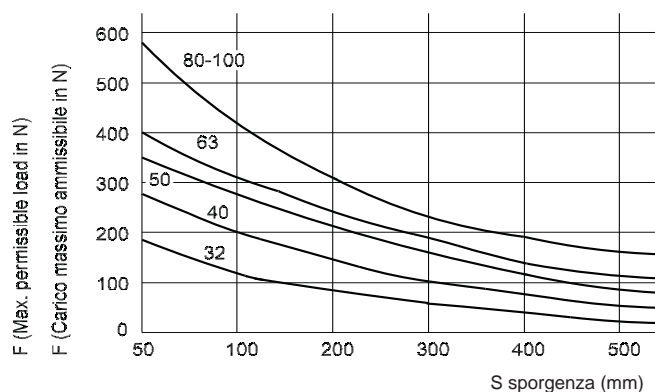
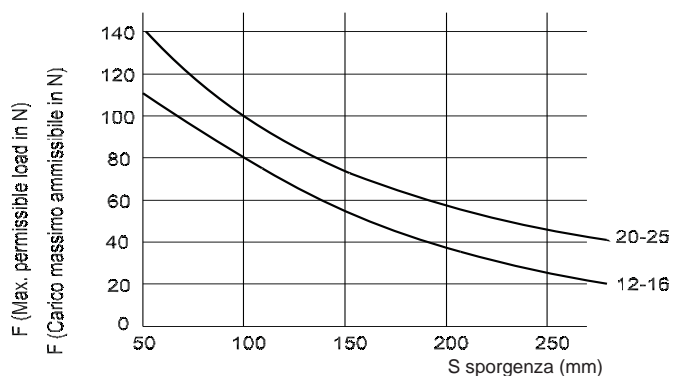

TIPO U CON BUSSOLE IN BRONZO
U TYPE WITH SLIDE BEARINGS

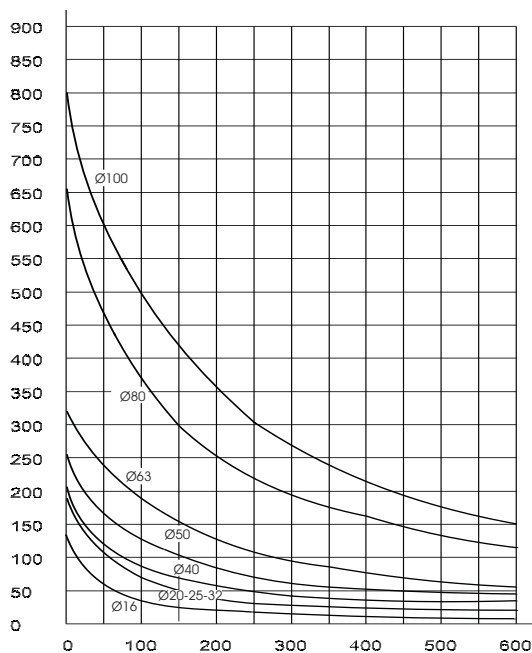
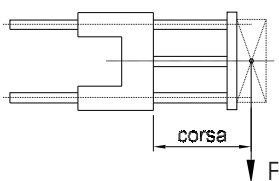

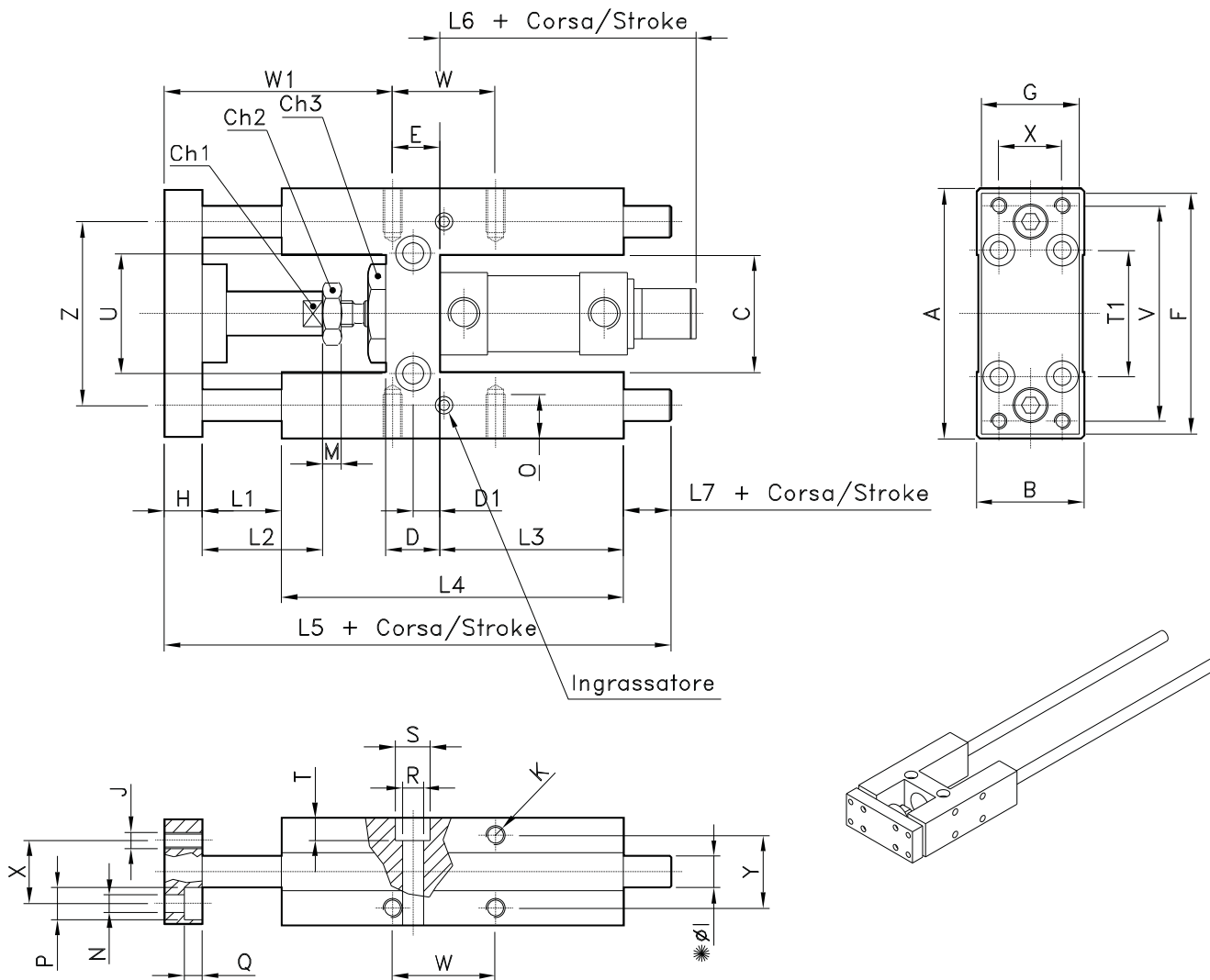

GIUNTO CORTO / SHORT COUPLING

Ø	L1	L2	L6	W1
20-25	3	18	43	50

GIUNTO LUNGO / LONG COUPLING

- * O1 = con bussole in bronzo / with slide bearings
- O2 = con cuscinetti a riciccolo di sfere / with ball bushings

Ø	A	B	C	Ch1	Ch2	Ch3	D	D1	E	F	G	H	Ø11	Ø12	J	K	L1	L2	L3
12 - 16	69	30	30	8	10	24	12	6	8	66	29	10	10	8	M4	M4	25	18	46
20	79	34	37	12	13	27	17	8.5	15	78	32	12	12	10	M5	M6	25	40	58
25	79	34	37	12	17	27	17	8.5	15	78	32	12	12	10	M5	M6	25	40	58

Ø	L4	L5	L6	L7	M	N	O	P	Q	R	S	T	T1	U	V	W	W1	X	Y	Z
12 - 16	68	123.5	73	20.5	4	4.5	6	8	4.5	5.5	9	5.5	32	24	58	18	49	18	22	49.5
20	108	166	87	21	5	5.5	9	10	7.5	6.5	11	6.5	38	38	68	32.5	20	72	23	58
25	108	166	91	21	6	5.5	9	10	7.5	6.5	11	6.5	38	38	68	32.5	20	72	23	58

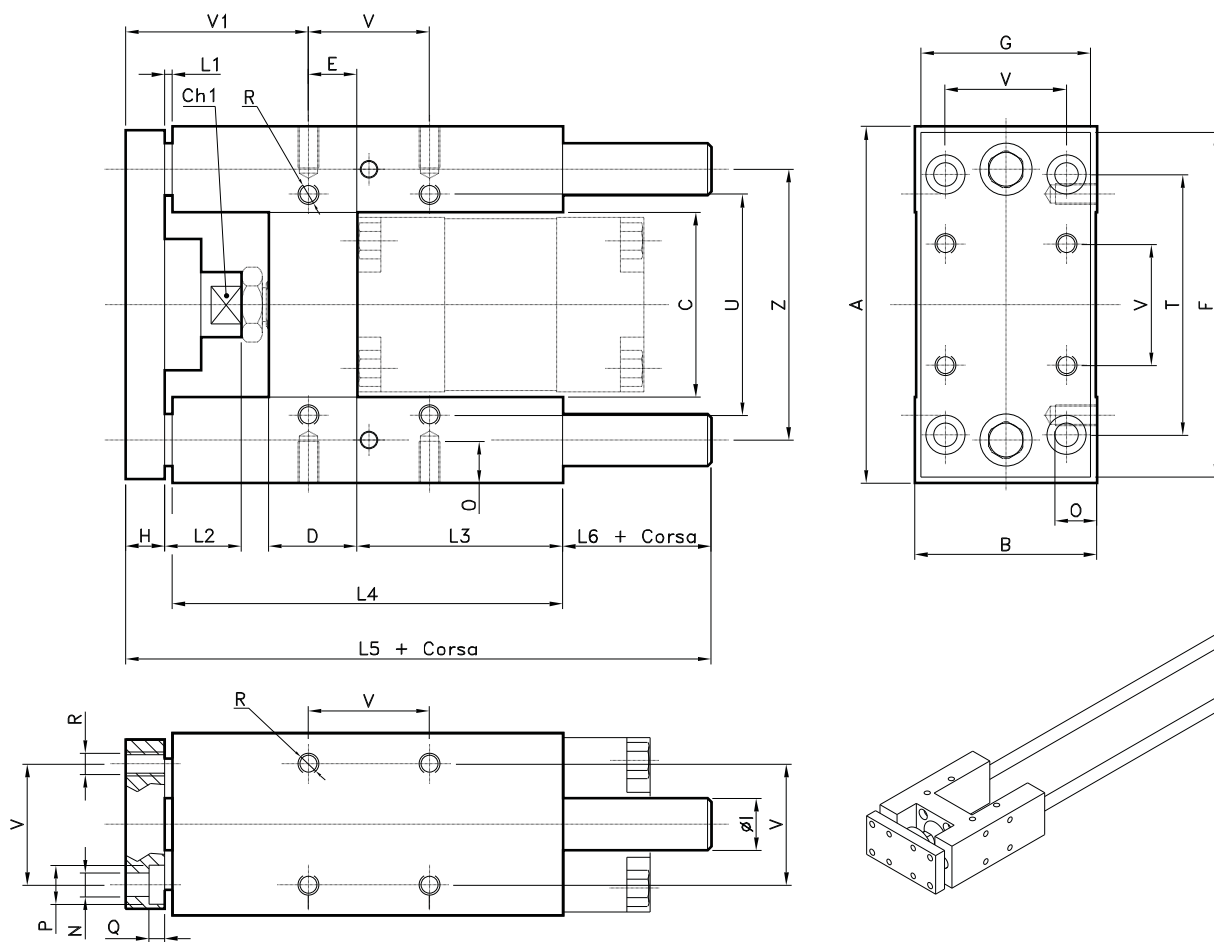

GIUNTO LUNGO / LONG COUPLING

Ø	A	B	C	Ch	D	E	F	G	H	ØI	L1	L2	L3	L4	L5	L6	N	O	P	Q	R	T	U	V	V1	Z
32	97	49	51	15	24	4.3	93	45	12	12	25	42	75	125	187	25	6.6	12	11	6.5	M6	78	61	32.5	82.7	74
40	115	58	58.2	15	28	11	112	55	12	16	25	42	80	140	207	30	6.6	12	11	6.5	M6	84	69	38	86	87
50	137	70	70.2	20	34	18.8	134	65	15	20	25	50	78	148	223	35	9	16	15	8.5	M8	100	85	46.5	91.2	104
63	152	85	85.2	20	34	15.3	147	80	15	20	25	50	106	178	243	25	9	16	15	9	M8	105	100	56.5	96.7	119
80	189	105	105.5	26	50	25	180	100	20	25	25	50	111	195	267	27	11	20	18	11	M10	130	130	72	104	148
100	213	130	130.5	26	55	30	206	120	20	25	25	50	128	218	290	27	11	20	18	11	M10	150	150	89	105	173

GIUNTO CORTO
SHORT COUPLING

Ø	L1	L2	L6	V1
32	3	19	47	60.7
40	3	24	52	64
50	3	27	57	69.2
63	3	27	47	74.7
80	3	27	49	82
100	3	27	49	83

Pesi / Weights

Ø	12	20	32	40	50	63	80	100
	16	25						
Peso in Kg. (Corsa 0) Weight in Kg. (Corsa 0)	0.4	0.9	1.3	2.4	3.5	4.6	8.4	11.8
Incremento ogni 100 mm Increase every 100 mm	0.12	0.18	0.18	0.32	0.5	0.5	0.77	0.77

UNITA' DI GUIDA PER CIL. ISO 6432
GUIDE UNITS FOR CYL. ISO 6432

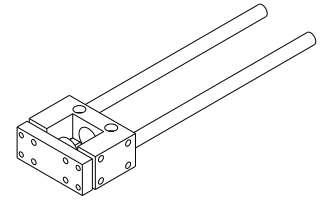
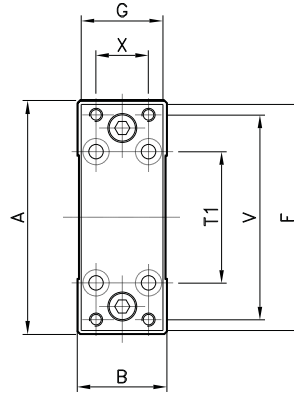
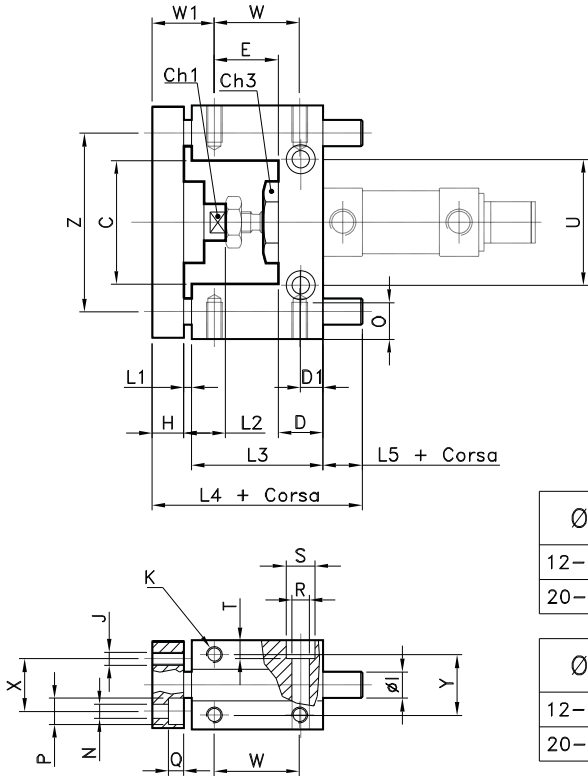

Ø	A	B	C	Ch1	Ch2	D	D1	E	F	G	H	ØI1	J	K	L1	L2	L3
12-16	69	30	30	8	24	12	6	19.5	66	29	10	10	M4	M4	3	15	38
20-25	79	34	37	12	27	17	8.5	24.25	78	32	12	12	M5	M6	3	18	48

Ø	L4	L5	N	O	P	Q	R	S	T	T1	U	V	W	W1	X	Y	Z
12-16	66.5	15.5	4.5	6	7.5	4.5	5.5	9	5.5	32	24	58	25	19.5	18	22	49.5
20-25	83	20	5.5	9	10	7.5	6.5	11	6.5	38	38	68	32.5	21.75	20	23	58

UNITA' DI GUIDA PER CIL. ISO 15552
GUIDE UNITS FOR CYL. ISO 15552

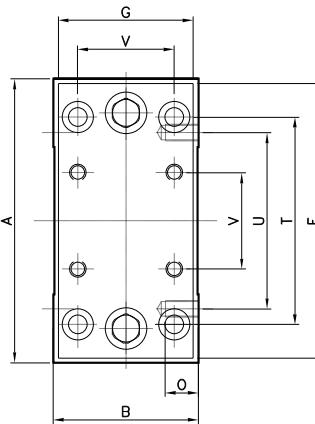
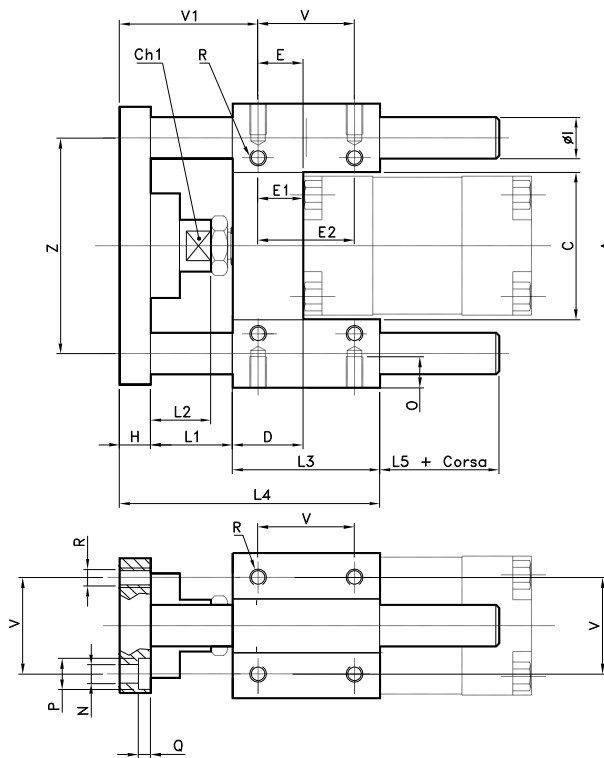

Pesi / Weights

Ø	12 16	20 25	32	40	50	63	80	100
Peso in Kg. (Corsa 0) Weight in Kg. (Corsa 0)	0.28	0.48	0.75	1.23	2.15	2.89	5.7	7.95
Incremento ogni 100 mm Increase every 100 mm	0.123	0.178	0.178	0.316	0.5	0.5	0.77	0.77

Ø	A	B	C	Ch	D	E	E1	E2	F	G	H	ØI	L1	L2	L3	L4	L5	N	O	P	Q	R	T	U	V	V1	Z
32	97	49	51	15	17	9.25	9.25	32.5	93	45	12	12	42	25	48	102	18	6.6	12	11	6.5	M6	78	61	32.5	61.75	74
40	115	58	58.2	15	21	11	11	38	112	55	12	16	43	25	58	113	17	6.6	12	11	6.5	M6	84	69	38	65	87
50	137	70	70.2	20	25	18.8	18.8	46.5	134	65	15	20	49	29	59	123	20	9	16	15	8.5	M8	100	85	46.5	70.2	104
63	152	85	85.2	20	25	15.3	15.3	56.5	147	80	15	20	49	29	76	140	21	9	16	15	9	M8	105	100	56.5	73.7	119
80	189	105	105.5	26	34	25	14	50	180	100	20	25	53	27	90	163	30	11	20	18	11	M10	130	130	72	82	148
100	213	130	130.5	26	39	28.5	19	70	206	120	20	25	54	27	110	184	30	11	20	18	11	M10	150	150	89	84.5	173



I cilindri rotanti AW sono stati concepiti per trasformare il moto rettilineo, tipico dei cilindri pneumatici, in moto rotatorio dotato di coppia torcente. Sono forniti con ammortizzo pneumatico ed hanno la possibilità di regolare l'angolo di rotazione di circa 10°. Una speciale regolazione, mediante pattino guida, riduce al minimo il gioco tra pignone e cremagliera.

Su richiesta vengono fornite rotazioni speciali.

Air Work rotary cylinders are engineered in order to transform the rectilinear motion, typical of the pneumatic cylinders, into a rotating motion equipped with torque to us of twisting brace. They are supplied with pneumatic cushioning and the angle of spin can be regulated adjusted of about 10°.

A special regulation, by means of guide, reduces the clearance between pinion and rack.

CHIAVE DI CODIFICA / KEY TO TYPE NUMBER

RY_00_1_000_000

ANGOLO DI ROTAZIONE / ANGLE OF ROTATION

Ø CILINDRO / Ø CYLINDER

VERSIONE - VERSION

01=PIGNONE MASCHIO - CON REGOLAZIONE - MAGNETICO

MALE PINION - WITH ADJUSTMENT - MAGNETIC

03=PIGNONE FEMMINA - CON REGOLAZIONE - MAGNETICO

FEMALE PINION - WITH ADJUSTMENT - MAGNETIC

05=PIGNONE MASCHIO - SENZA REGOLAZIONE - MAGNETICO

MALE PINION - WITHOUT ADJUSTMENT - MAGNETIC

07=PIGNONE FEMMINA - SENZA REGOLAZIONE - MAGNETICO

FEMALE PINION - WITHOUT ADJUSTMENT - MAGNETIC

VERSIONE - VERSION

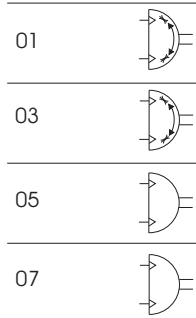

DATI TECNICI / TECHNICAL DATA

Fluido / Fluid	Aria con o senza lubrificazione / Lubricated or non lub. Air
Temp. di esercizio / Operating temp. range	-5C° / +80C°
Press. massima di esercizio / Max operating press.	10 bar
Regolazione angolo / Angle of rotation adjustment	10°
taglie / sizes	Ø 32-40-50-63-80-100-125
rotazioni standard / standard rotations	90° - 180° - 270° - 360°

COMPONENTI / COMPONENTS

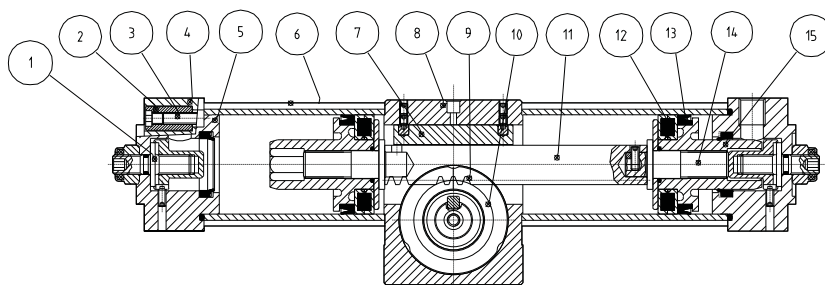

pos.	descrizione / description	materiale / material
1	vite di regolazione / regulator screw	acciaio / steel
2	dado / nut	acciaio / steel
3	firante / rod	acciaio / steel
4	testata / cap	alluminio / aluminium
5	guarnizione amm. / cushion seal	poliuretano / polyurethane
6	tubo / tube	alluminio / aluminium
7	guida cremagliera / guide for rack	Delring
8	corpo / body	alluminio / aluminium
9	pignone / pinion	acciaio / steel
10	cuscinetto a sfere / ball bearings	acciaio / steel
11	cremagliera / rack	acciaio / steel
12	magnete / magnet	plastroferrite
13	guarnizioni pistone / piston seal	poliuretano / polyurethane
14	dado / nut	acciaio / steel
15	pistone / piston	Delring

CARICO AMMISSIBILE / ADMISSIBLE LOAD

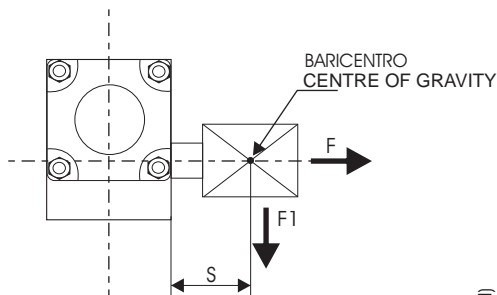

CARICO ASSIALE F MAX CON $F_1=0$
MAX AXIAL LOAD F WITH $F_1=0$

	F (N)
Ø32	100 N
Ø40	100N
Ø50	120N
Ø63	120N
Ø80	200N
Ø100	250N
Ø125	300N

CARICO RADIALE F1 MAX CON $F=0$
MAX RADIAL LOAD F1 WITH $F=0$

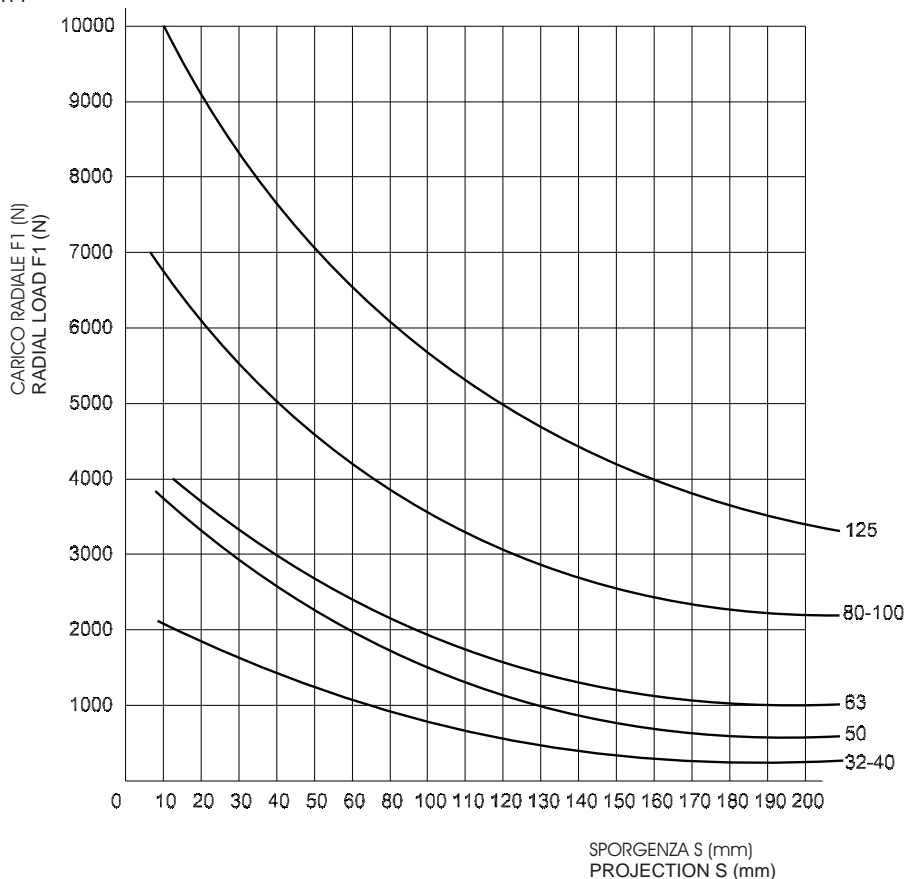

MOMENTO TORCENTE AD 1 BAR / TORQUE A 1 BAR

Ø32	1.2 Nm
Ø40	2.25 Nm
Ø50	3.9 Nm
Ø63	7.3 Nm
Ø80	15.7 Nm
Ø100	26.35 Nm
Ø125	51 Nm

CAMPI DI REGOLAZIONI ANGOLO / ADJUSTABLE ANGLE

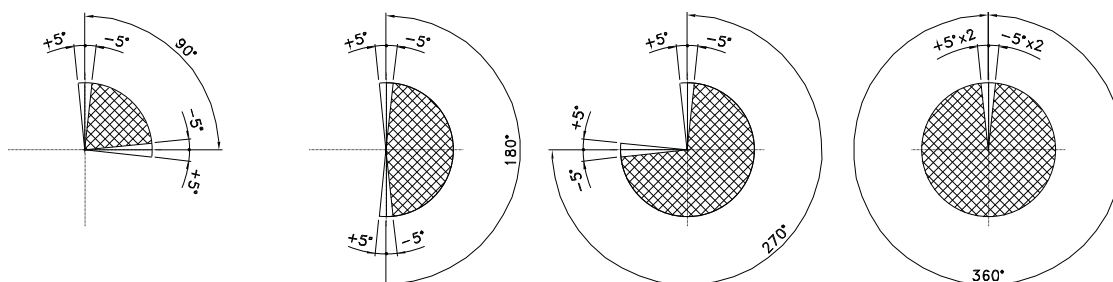

CILINDRO ROTANTE
PIGNONE
MASCHIO CON
REGOLAZIONE
ROTARY CYLINDER MALE
PINION WITH
ADJUSTMENT OF THE
ROTATION

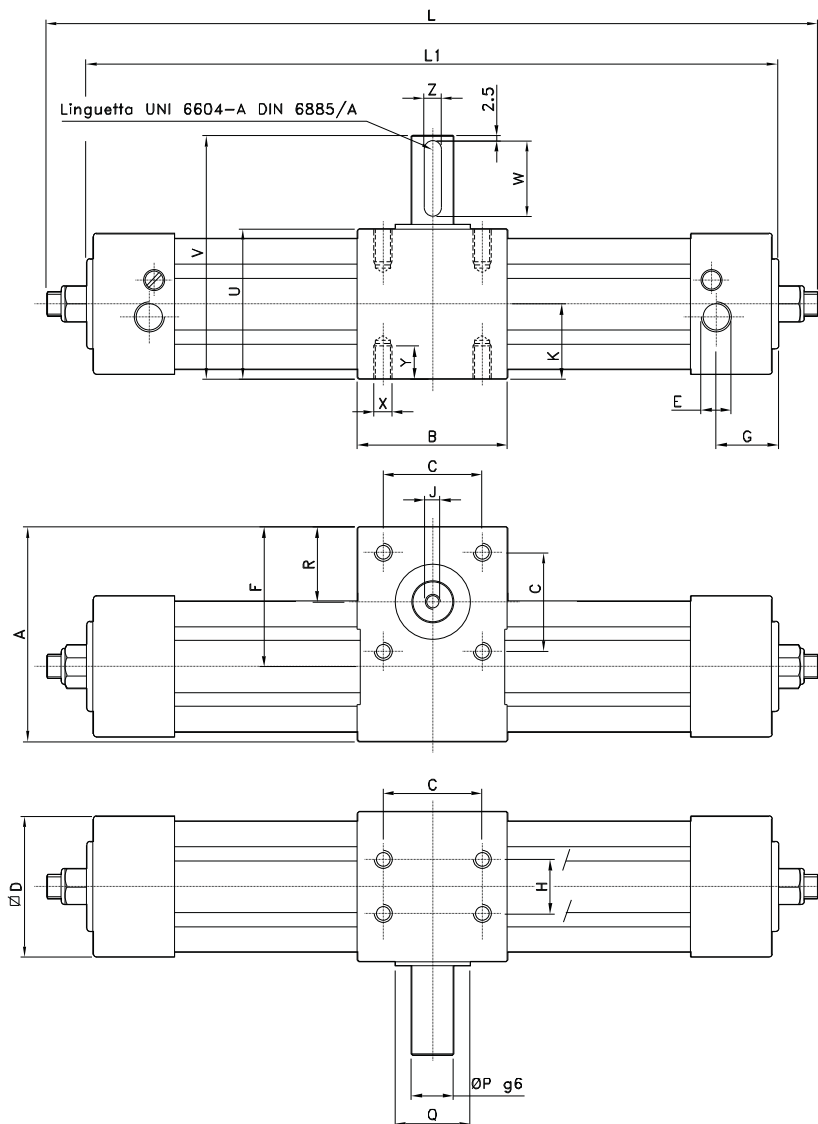

Ø	A	B	C	D	E	F	G	H	J	K	P	Q	R	U	V	X	Y	Z	W
32	71.5	50	33	48	1/8"G	46.5	18	18	M5	25	14	25	25	50	81	M6	10	5	25
40	82	60	40	54	1/4"G	54.5	21	22	M5	30	14	25	30	60	91	M6	10	5	25
50	93	70	50	67	1/4"G	60.5	24	25	M6	32.5	19	30	32.5	65	106	M8	13	6	35
63	109	75	60	78	3/8"G	70.8	26	35	M8	37.5	24	30	37	75	116	M8	13	8	35
80	142	99	80	97	3/8"G	93.5	26	50	M8	49.5	28	45	50	99	150	M10	16	8	45
100	156.5	115	80	115	1/2"G	99	30	60	M10	57.5	38	50	54	115	166	M10	16	10	45
125	188	125	90	140	1/2"G	118	32	70	M10	70	38	60	60	140	191	M12	20	10	45

Dimensioni L e L1 per rotazioni standard Dimensions L and L1 for standard rotations								
Cilindro rotante Ø Rotary cylinder Ø	Rotazione 90° 90° Rotation		Rotazione 180° 180° Rotation		Rotazione 270° 270° Rotation		Rotazione 360° 360° Rotation	
	L	L1	L	L1	L	L1	L	L1
	32	232	213	279	260	326	307	373
40	274	254	330	310	387	367	464	424
50	301	276	364	339	427	402	489	464
63	343	320	418	395	493	470	567	544
80	416	386	515	485	614	584	713	683
100	449	418	556	525	662	631	769	738
125	518	487	650	619	782	751	914	883

CILINDRO ROTANTE PIGNONE
FEMMINA CON REGOLAZIONE
ROTARY CYLINDER FEMALE
PINION WITH ADJUSTMENT OF
THE ROTATION

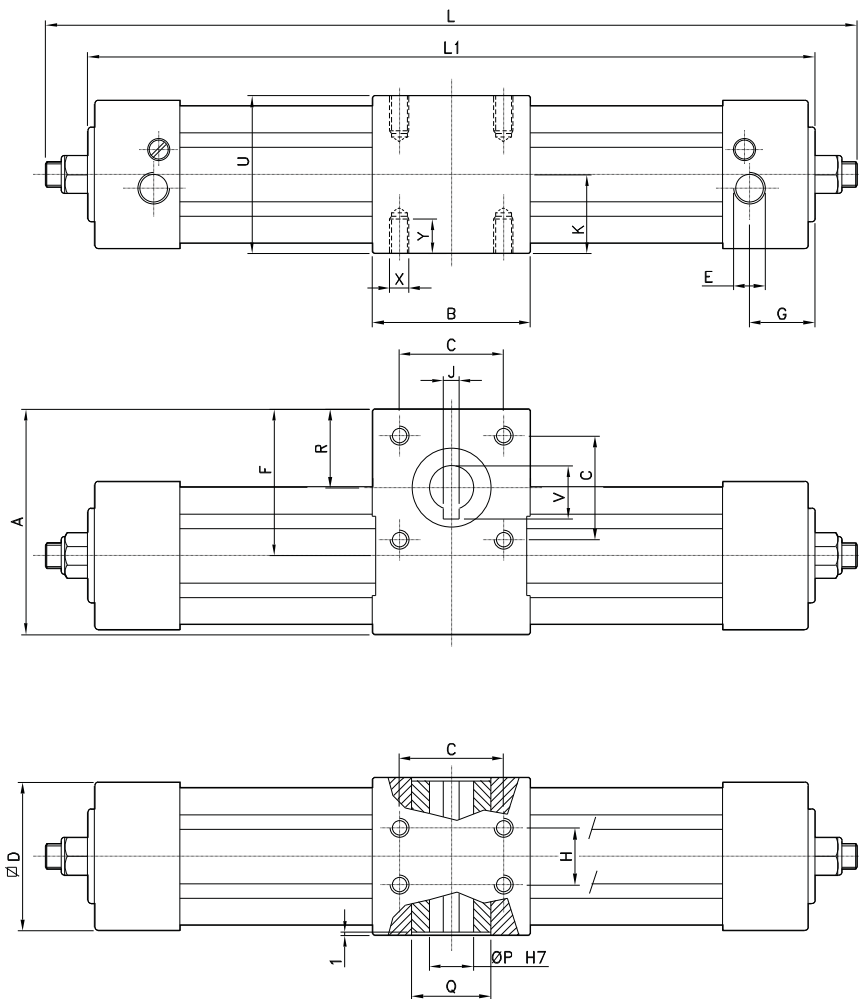

Ø	A	B	C	D	E	F	G	H	J	K	P	Q	R	U	V	X	Y
32	71.5	50	33	48	1/8"G	46.5	18	18	5	25	14	25	25	50	16.3	M6	10
40	82	60	40	54	1/4"G	54.5	21	22	5	30	14	25	30	60	16.3	M6	10
50	93	70	50	67	1/4"G	60.5	24	25	6	32.5	19	30	32.5	65	21.8	M8	13
63	109	75	60	78	3/8"G	70.8	26	35	6	37.5	19	30	37	75	21.8	M8	13
80	142	99	80	97	3/8"G	93.5	26	50	8	49.5	24	45	50	99	27.3	M10	16
100	156.5	115	80	115	1/2"G	99	30	60	8	57.5	28	50	54	115	31.3	M10	16
125	188	125	90	140	1/2"G	118	32	70	8	70	28	60	60	140	31.3	M12	20

Dimensioni L e L1 per rotazioni standard Dimensions L and L1 for standard rotations								
Ø	Rotazione 90° 90° Rotation		Rotazione 180° 180° Rotation		Rotazione 270° 270° Rotation		Rotazione 360° 360° Rotation	
	L	L1	L	L1	L	L1	L	L1
32	232	213	279	260	326	307	373	354
40	274	254	330	310	387	367	464	424
50	301	276	364	339	427	402	489	464
63	343	320	418	395	493	470	567	544
80	416	386	515	485	614	584	713	683
100	449	418	556	525	662	631	769	738
125	518	487	650	619	782	751	914	883

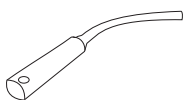
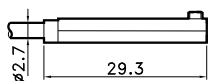

SENSORE OVALE
OVAL SWITCH
CODE

AR4019010 REED 2 FILI / REED WITH 2 WIRES
AR4019020 HALL 3 FILI / HALL WITH 3 WIRES

DATI TECNICI / TECHNICAL DATA

Grado di protezione / Protection class	IP 67 EN 60529
Temper. Di impiego / Working temp.	-20C° +85C°
Materiale custodia / Housing material	PA
Tensione in DC / Tension in DC	Reed 3-30V / Hall 6-30V
Tensione in AC / Tension in AC	Reed 3-30V
Corrente a 25 C° / Current at 25 C°	Reed 0,20A / Hall 0,20A
Tempo inserzione / On time	Reed 0,5mS / Hall 0,8 uS
Tempo disinserione / Off time	Reed 0,1mS / Hall 0,3 uS

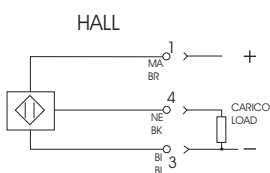

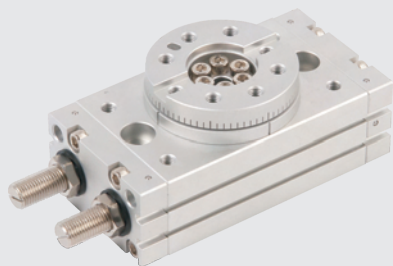

Gli attuatori Rotanti AW sono stati ricavati da un apposito profilo in alluminio. I loro ingombri molto contenuti e l'estrema pulizia del disegno, rendono questi prodotti particolarmente apprezzati.
Sono a doppia cremagliera con angolo di rotazione da 0° a 180°.
Sul corpo sono state ricavate scanalature per l'inserimento di sensori magnetici

AIRWORK'S rotary actuators Series AT are obtained from a profile in aluminum. The very reduced dimensions and the extremely clean design render these products particularly interesting.
They are available with double rack and with angle of spin from 0° to 180°.
Grooves are obtained on the body in order to mount magnetic sensors

CHIAVE DI CODIFICA / KEY TO TYPE NUMBER

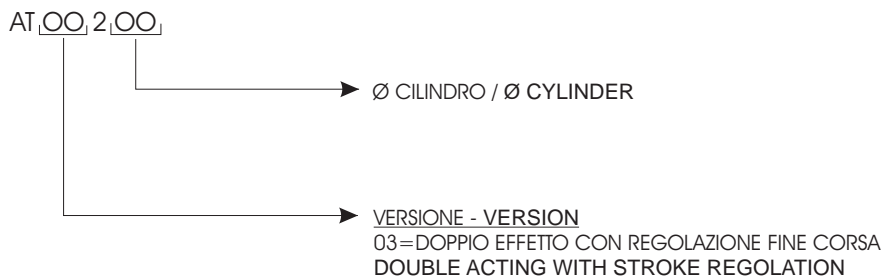

DATI TECNICI / TECHNICAL DATA

Taglie / sizes	Ø15 - 18 - 20 - 25
Fluido - Fluid	Aria con o senza lubrificazione - Lubricated or non lubricated air
Temperatura di esercizio - Operating temperature range	-0C° / +90C°
Pressione massima di esercizio - Max operating pressure	7 bar
Rotazione angolo / Rotation angle	90° - 180°
Regolazione angolo / Adjustable angle	0° - 90°
Ammortizzo / cushioning	paracolpi elastico / rubber buffer

CARICO AMMISSIBILE / LOAD ADMISSED

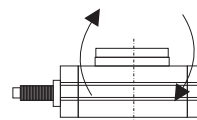
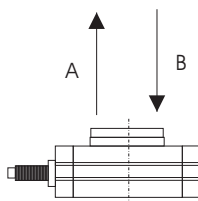
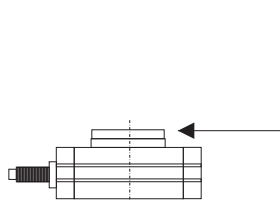

	Trasversale (N) transversal (N)	Assiale (N) Axial (N)	Mom.torcente (N.m) Allow torque (N.m)
Ø15	70	A=68 B=70	2
Ø18	140	A=130 B=130	3.5
Ø20	185	A=188 B=358	4.8
Ø25	300	A=285 B=442	9

COMPONENTI / COMPONENTS

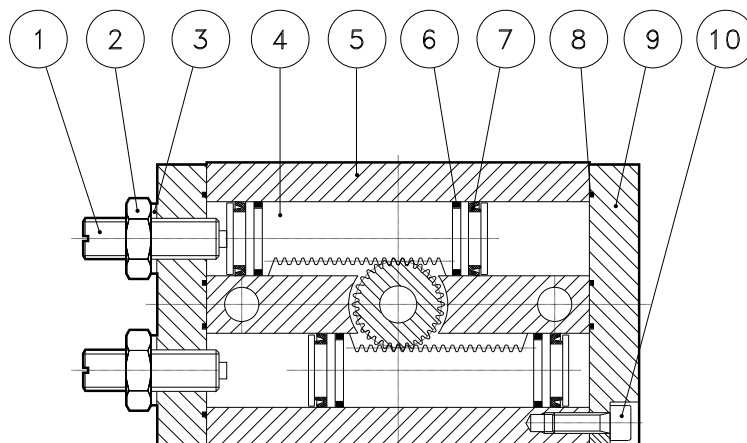
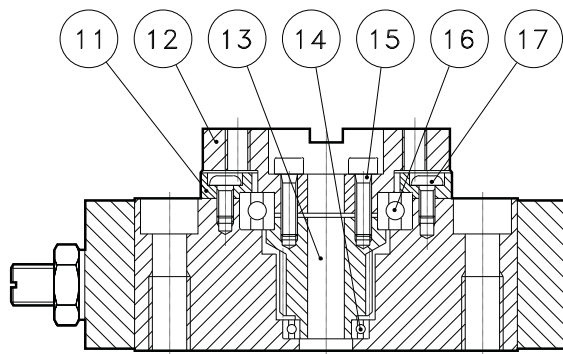

pos.	descrizione / description	materiale / material
1	vite di regolazione / regulation screw	acciaio / steel
2	dado di fermo / stop nut	acciaio / steel
3	rondella / ring	acciaio+NBR / steel+NBR
4	pistone cremagliera / piston rack	acciaio AISI 316 / stainless steel AISI 316
5	corpo / body	alluminio / aluminium
6	anello di guida / guide ring	PTFE
7	guarnizione pistone / piston seal	poliuretano / polyuretane
8	o-ring	NBR
9	testata / cap	alluminio / aluminium
10	vite / screw	acciaio / steel
11	piastra di fermo / stop plate	alluminio / aluminium
12	tavola girevole / turning plate	alluminio / aluminium
13	pignone / pinion	acciaio / steel
14	cuscinetto a sfera / ball bearing	acciaio / steel
15	vite / screw	acciaio / steel
16	cuscinetto a sfera / ball bearing	acciaio / steel
17	vite / screw	acciaio / steel

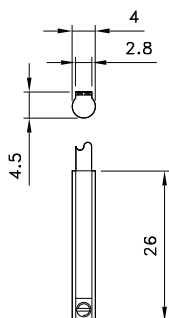

SENSORE TONDO
ROUND SWITCH
CODE

AR4018010

REED 2 FILI / REED WITH 2 WIRES

CODE: AT0315

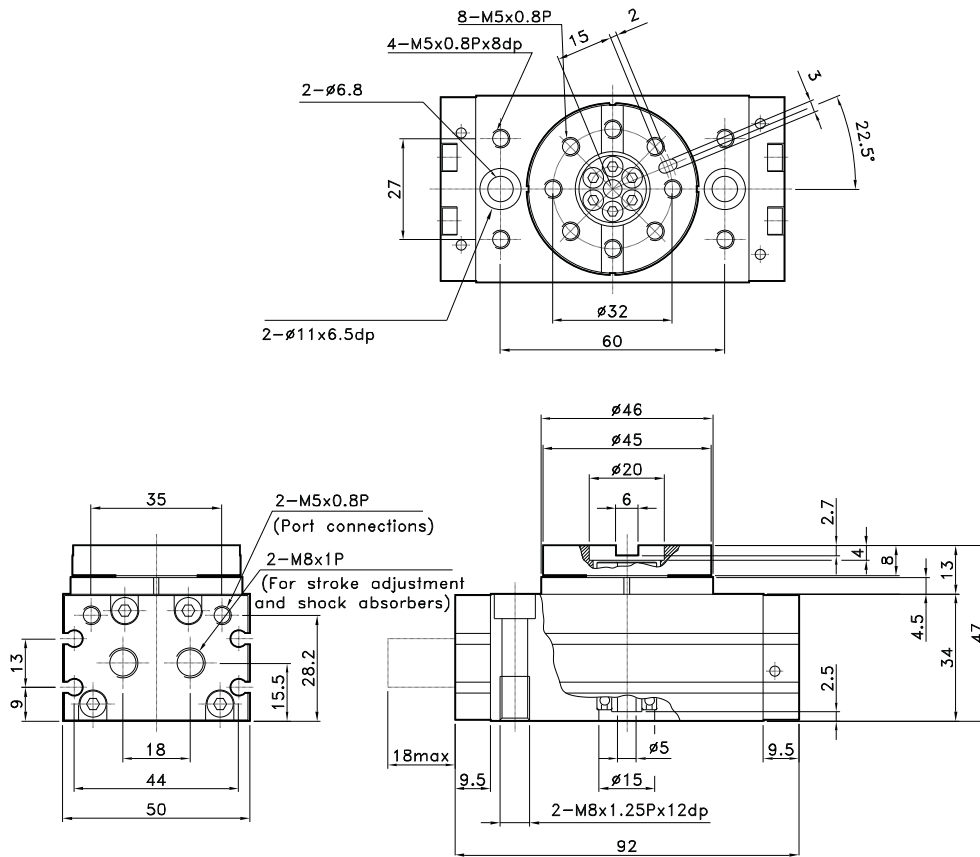

CODE: AT0318

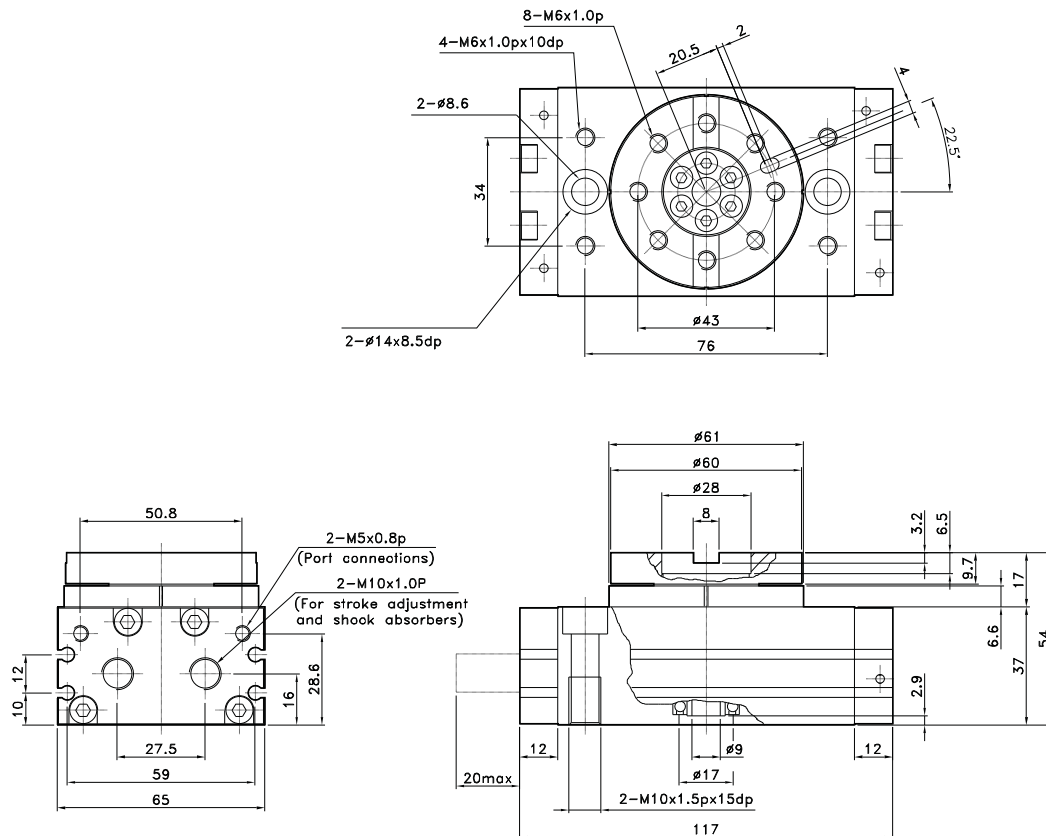

CODE: AT0320

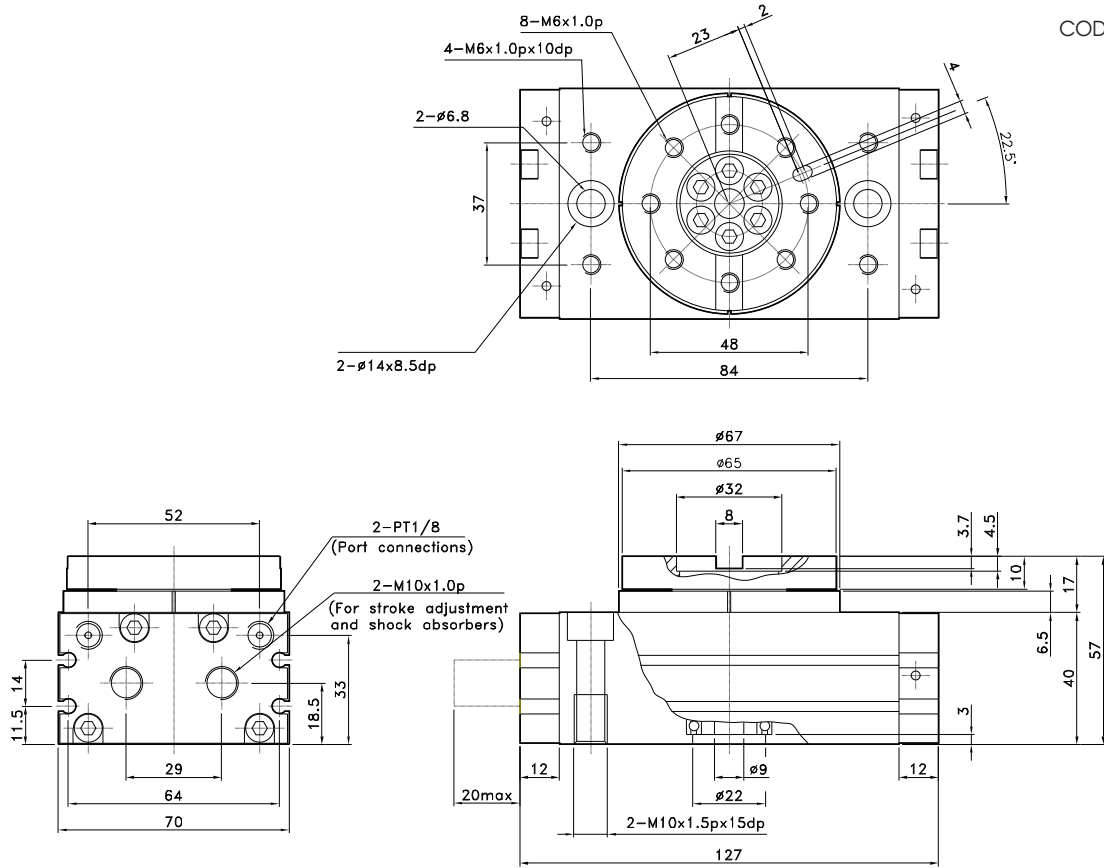

CODE: AT0325

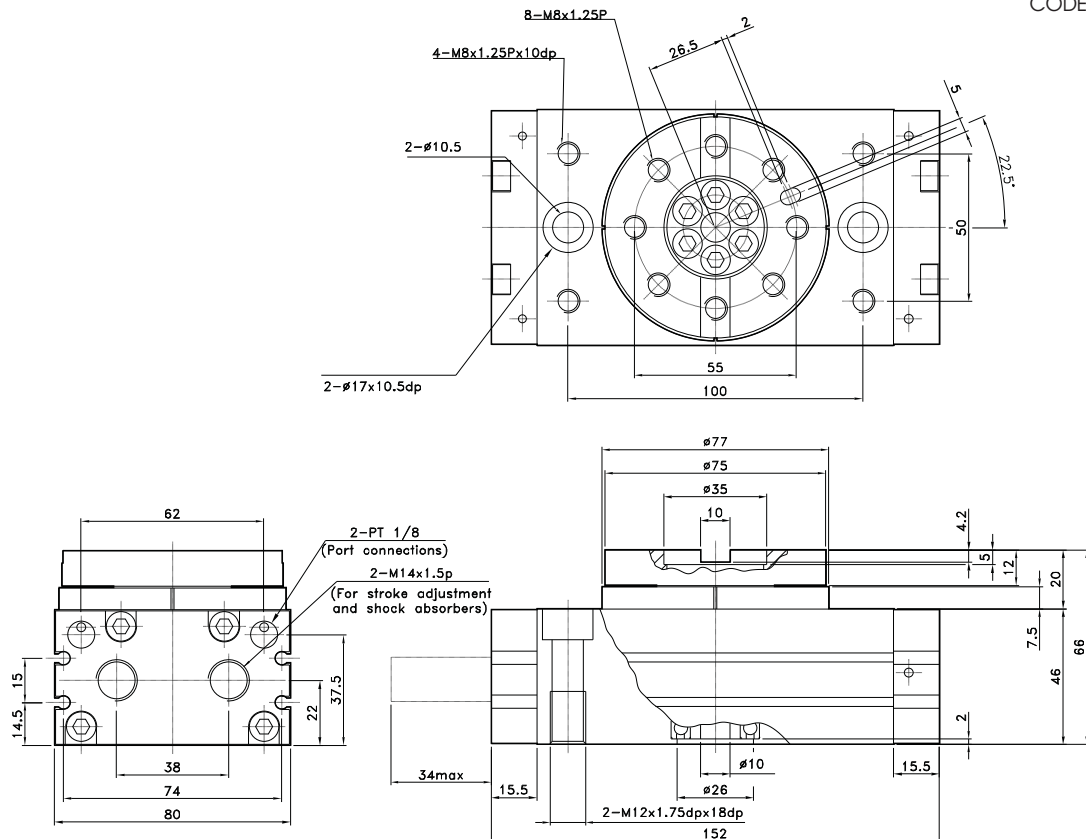



Il freno idraulico AW è un sistema ad olio a circuito chiuso da abbinare normalmente ad un cilindro pneumatico per ottenere un rallentamento regolabile della corsa. Sono disponibili diverse versioni: Regolazione in spinta, in trazione e doppia regolazione. E' prevista una valvola di Skip, Stop od entrambe.

AIRWORK hydraulic speed regulator, is an oil system with closed circuit which has to be connected to a pneumatic cylinder in order to obtain an adjustable slowing down of the stroke. Several versions are available: Regulation in push, in traction and double regulation. It is available with one valve of Skip, Stop or both.

CHIAVE DI CODIFICA / KEY TO TYPE NUMBER

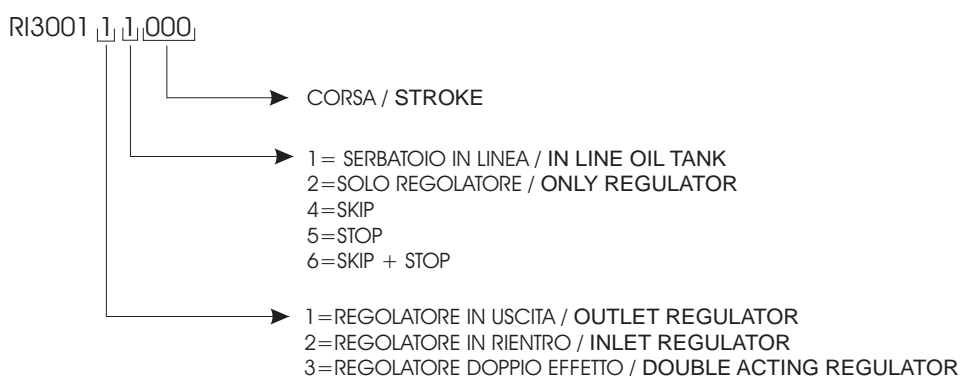

	SOLO REGOLAZIONE ONLY REGULATOR	CON SKIP WITH SKIP	CON STOP WITH STOP	CON SKIP E STOP WITH SKIP AND STOP
REGOLATORE IN USCITA OUTLET REGULATOR				
REGOLATORE IN RIENTRO INLET REGULATOR				
REGOLATORE DOPPIO EFFETTO DOUBLE ACTING REGULATOR				

CORSE STANDARD - STANDARD STROKES

Ø40 50-100-150-200-250-300-350-400-450-500

DATI TECNICI / TECHNICAL DATA

Carico max./ Max load	600Kg
Velocita min./max / Max./Min speed	60 - 10000mm/min
Temperatura di esercizio / Temperature range	-10°C / +70°C
Olio circuito / oil circuit	Idraulico con viscosita' 2,9E 50°C
Pressione min. per l'azionamento delle valvole di skip e stop Minimum pressure start valve skip and stop	4 bar

COMPONENTI / COMPONENTS

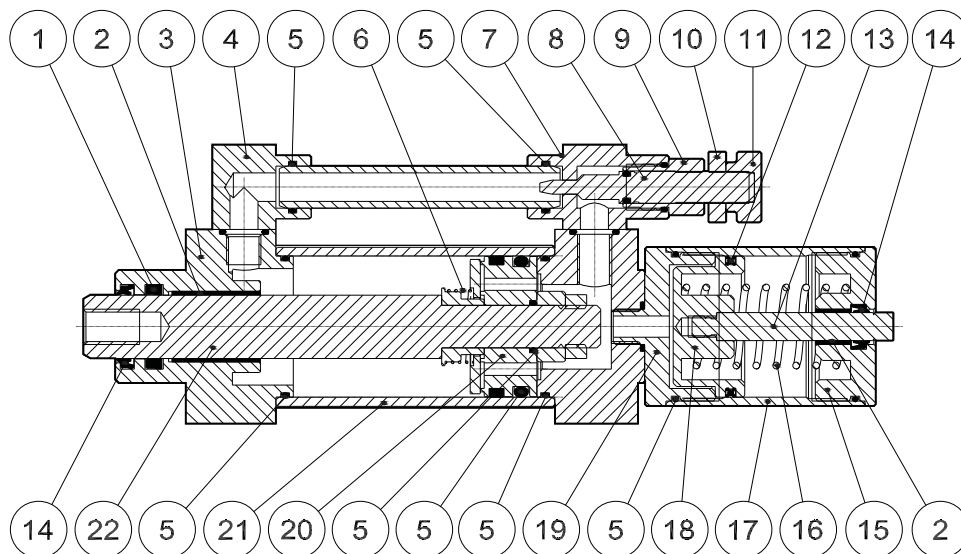

pos.	descrizione / description	materiale / material
1	Guarnizioni / Seals	Poliuretano / Polyurethane
2	Bullola guida / Slide bearing	Acciaio+PTFE / Steel+PTFE
3	Testata anteriore / Front cap	Alluminio / Aluminium
4	Collettore	Alluminio / Aluminium
5	OR	NBR
6	Molla / Spring	Acciaio / Steel
7	Basetta / Manifold	Alluminio / Aluminium
8	Spillo / Screw	Acciaio / Steel
9	Corpo / Body	Acciaio / Steel
10	Ghiera di arresto / Stop metal ring	Acciaio / Steel
11	Ghiera di regolazione / Metal ring for regulation	Acciaio / Steel
12	OR	NBR
13	Stelo / Rod	Acciaio / Steel
14	Guarnizione / Seal	Poliuretano / Polyurethane
15	Tappo / Plug	Alluminio / Aluminium
16	Molla / Spring	Acciaio / Steel
17	Tubo / Tube	Acciaio / Steel
18	Pistone / Piston	Alluminio / Aluminium
19	Base / Base	Alluminio / Aluminium
20	Pistone / Piston	Alluminio / Aluminium
21	Tubo / Tube	Acciaio / Steel
22	Stelo / Rod	Acciaio / Steel

PRINCIPIO DI FUNZIONAMENTO / WORKING PRINCIPLE

Il principio di funzionamento dei regolatori idraulici di velocità sfrutta l'incompressibilità dell'olio che, passando dalla camera anteriore a quella posteriore (o viceversa) attraverso un regolatore di flusso assorbe e neutralizza le variazioni di velocità dell'attuatore lineare ad esso collegato. I regolatori di velocità idraulici sono in grado di scomporre con opportuni accorgimenti le varie fasi di lavorazione, consentendo avvicinamenti rapidi, fasi di lavoro più o meno lente, successive fasi di movimento accelerato per l'avvicinamento ad esempio al pezzo successivo (con valvole di by-pass chiamate skip), inoltre si possono anche dotare di valvole di stop che permettono di bloccare e trattenere nella posizione raggiunta gli elementi in movimento ad essi collegati. Le valvole di skip e di stop sono delle valvole ad otturatore a 2 vie, azionate pneumaticamente, entrambe sono normalmente aperte pertanto è necessario erogare pressione pneumatica affinché la skip si escluda e la stop si inserisca. La valvola di skip è dotata di un regolatore supplementare per il controllo della velocità massima. Gli steli dei regolatori presentano un foro filettato M10x1,5 utilizzabile per il fissaggio, mentre per quanto riguarda l'ancoraggio dei regolatori di velocità alla macchina o al cilindro si possono sfruttare i fori filettati presenti sulle testate anteriori M6 abbinati anche alle piastre di collegamento opzionali. Tutti i regolatori di velocità hanno un serbatoio supplementare che serve per compensare la differenza di volume tra le due camere, determinata dalla presenza dello stelo in quella anteriore, e per ripristinare le perdite, seppur minime, che si verificano tra lo stelo e la guarnizione dello stesso. All'interno del serbatoio è presente un pistone mantenuto in pressione da una molla che assicura una leggera sovrappressione al sistema. Inoltre dal serbatoio fuoriesce un'astina con una tacca che indica il livello minimo dell'olio.

The operating principle of hydraulic speed governors is based on oil incompressibility: flowing from the front to the rear chamber (or vice-versa), through a flow regulator, it absorbs and neutralizes any speed variation in the linear actuator connected to it. Hydraulic speed governors can split, by means of suitable procedures, the different processing stages, and make it possible to approach the pieces more quickly, to speed-up or slow-down the processing steps, to accelerate, for example, the approach to the next piece (using by-pass valves known as skip valves); furthermore, they can be equipped with stop valves to clamp and hold all the moving pieces connected to them. The skip and stop valves are 2-way pneumatic glove valves; as a rule both of them are open, and therefore pneumatic pressure must be provided in order to shut-off the skip valve and turn-on the stop valve. The skip valve is provided with an auxiliary maximum speed governor. The governors' stems are provided with a threaded hole (M10x1.5) for clamping, while in order to secure speed governors to the machine or cylinder, you can use the threaded holes available on front heads (M6), coupled with optional connecting plates. All speed governors are provided with an auxiliary tank, to offset the volume difference between the two chambers (due to the presence of the stem in the front chamber) and to refill the unit after the leaks (even minimum) between the stem and its gasket. A piston inside the tank is pressed by a spring which ensure a slight overpressure within the system. Furthermore, a dip stick protrudes from the tank, to indicate minimum oil level.

REGOLAZIONE IN USCITA - SERBATOIO IN LINEA
OUTLET REGULATOR - IN LINE OIL TANK
CODE: RI300111.corsa/stroke

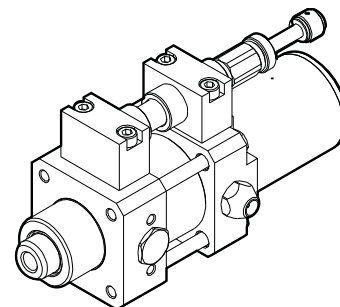
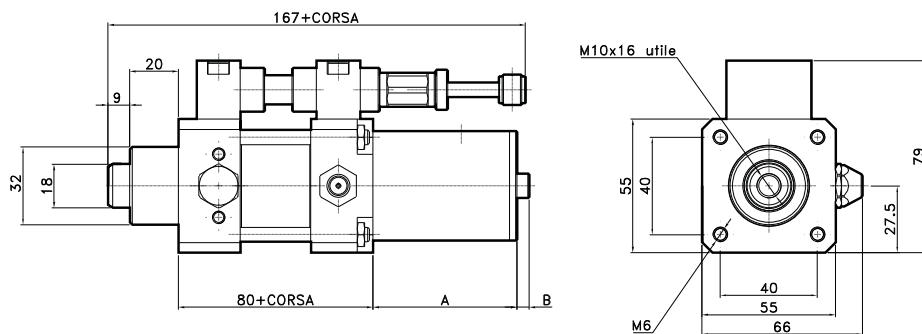
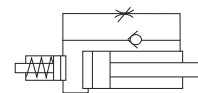

STROKES	A	B max.
< 75	75	25
75+150	90	39
150+250	142	65
250+350	171	87
350+500	222	125

REGOLAZIONE IN USCITA
OUTLET REGULATOR
CODE: RI300112.corsa/stroke

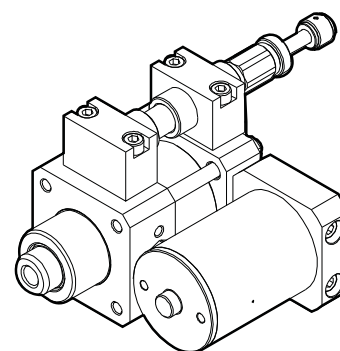
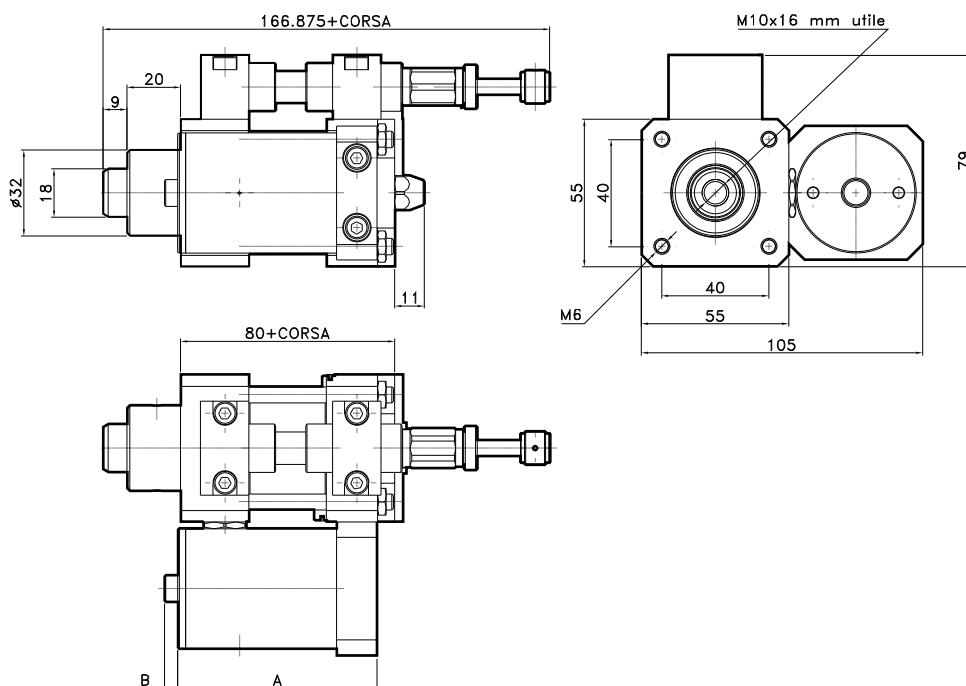
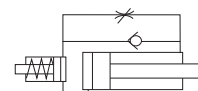

STROKES	A	B max.
< 75	75	25
75+150	90	39
150+250	142	65
250+350	171	87
350+500	222	125

REGOLAZIONE IN USCITA + VALVOLA SKIP / OUTLET REGULATOR + SKIP VALVE
CODE: RI300114.corsa/stroke

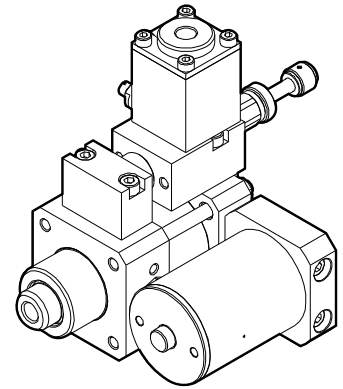
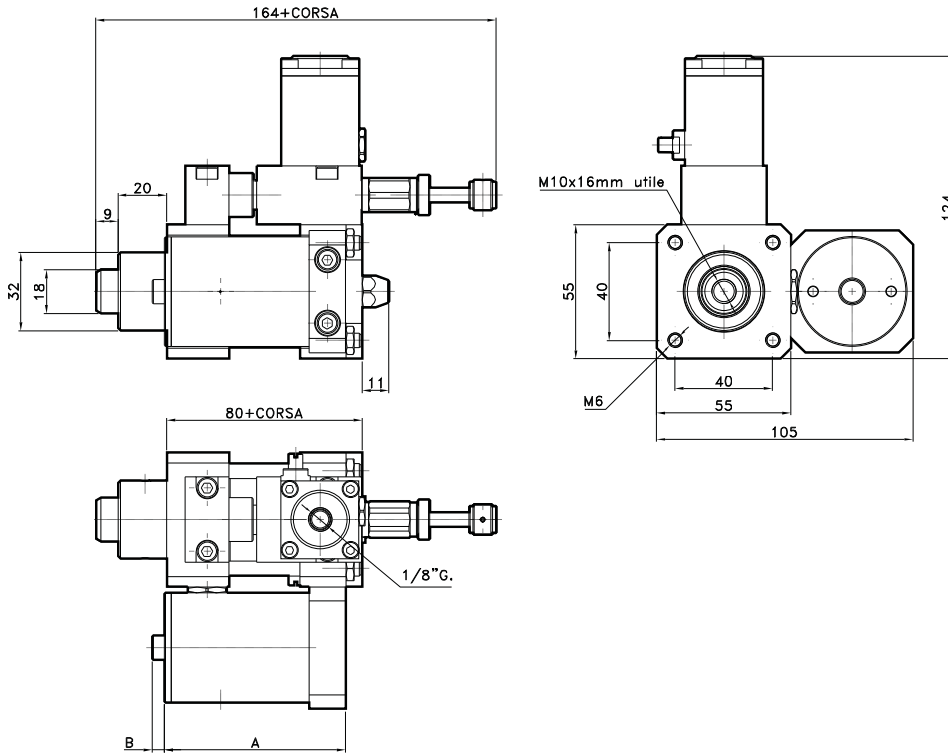
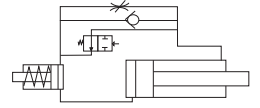

STROKES	A	B max.
< 75	75	25
75+150	90	39
150+250	142	65
250+350	171	87
350+500	222	125

REGOLAZIONE IN USCITA + VALVOLA STOP / OUTLET REGULATOR + STOP VALVE
CODE: RI300115.corsa/stroke

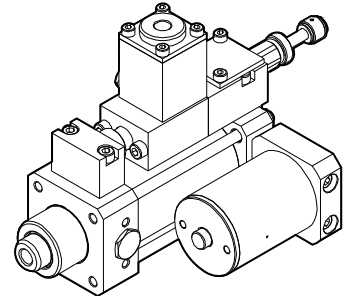
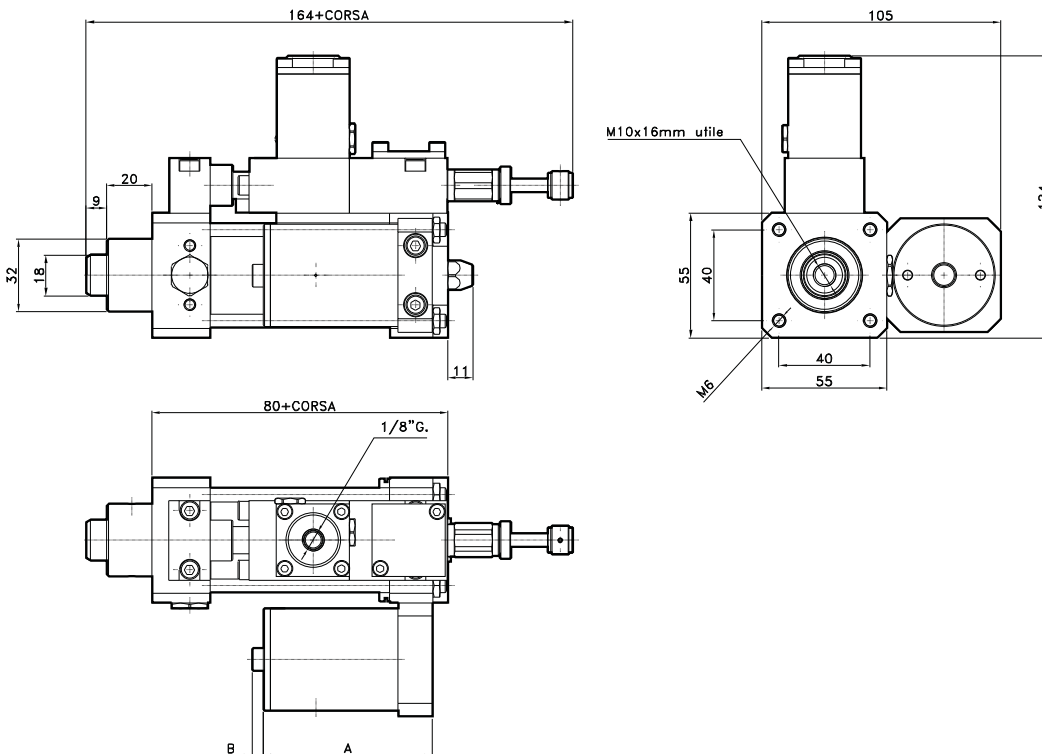
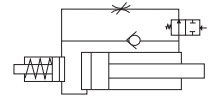

STROKES	A	B max.
< 75	75	25
75+150	90	39
150+250	142	65
250+350	171	87
350+500	222	125

REGOLAZIONE IN USCITA + VALVOLA SKIP + VALVOLA STOP / OUTLET REGULATOR + SKIP VALVE + STOP VALVE
CODE: RI300116.corsa/stroke

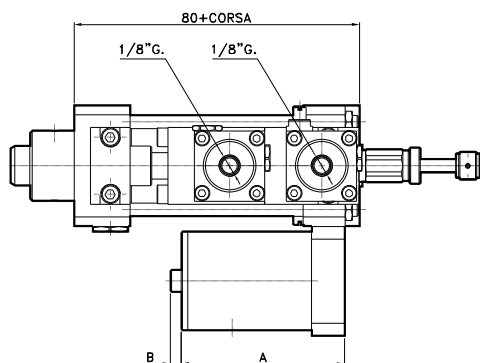
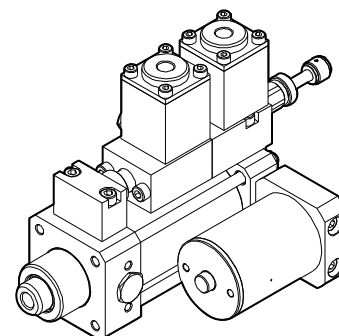
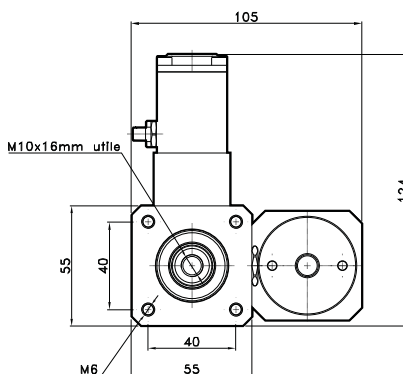
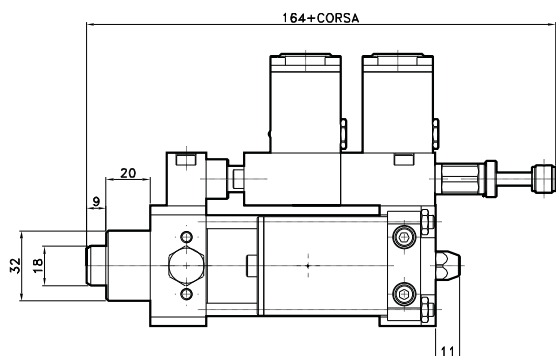
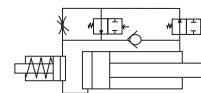

STROKES	A	B max.
< 75	75	25
75÷150	90	39
150÷250	142	65
250÷350	171	87
350÷500	222	125

REGOLAZIONE IN RIENTRO / INLET REGULATOR
CODE: RI300122.corsa/stroke

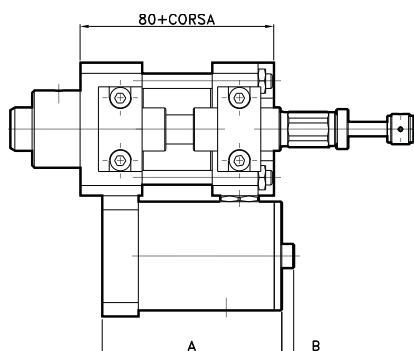
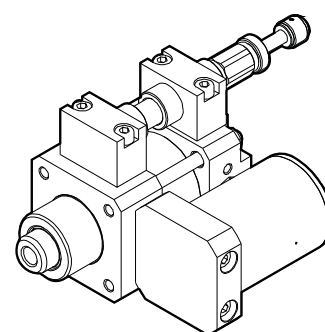
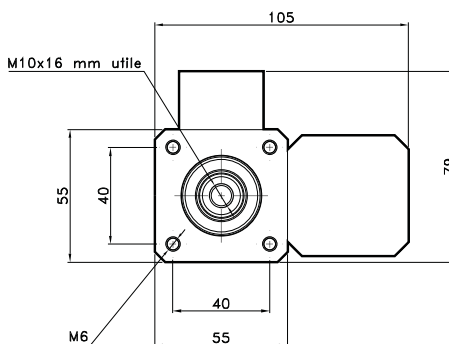
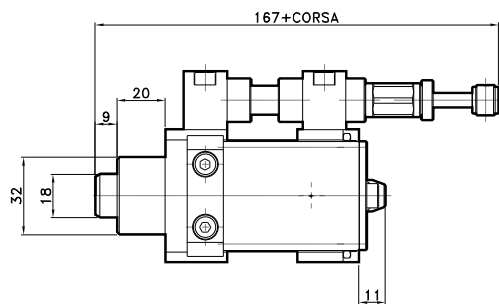
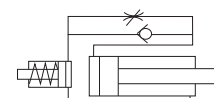

STROKES	A	B max.
< 75	75	25
75÷150	90	39
150÷250	142	65
250÷350	171	87
350÷500	222	125

REGOLAZIONE IN RIENTRO + VALVOLA SKIP / INLET REGULATOR + SKIP VALVE
CODE: RI300124.corsa/stroke

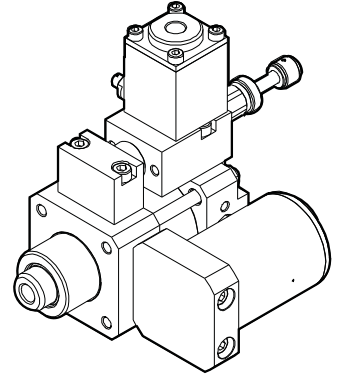
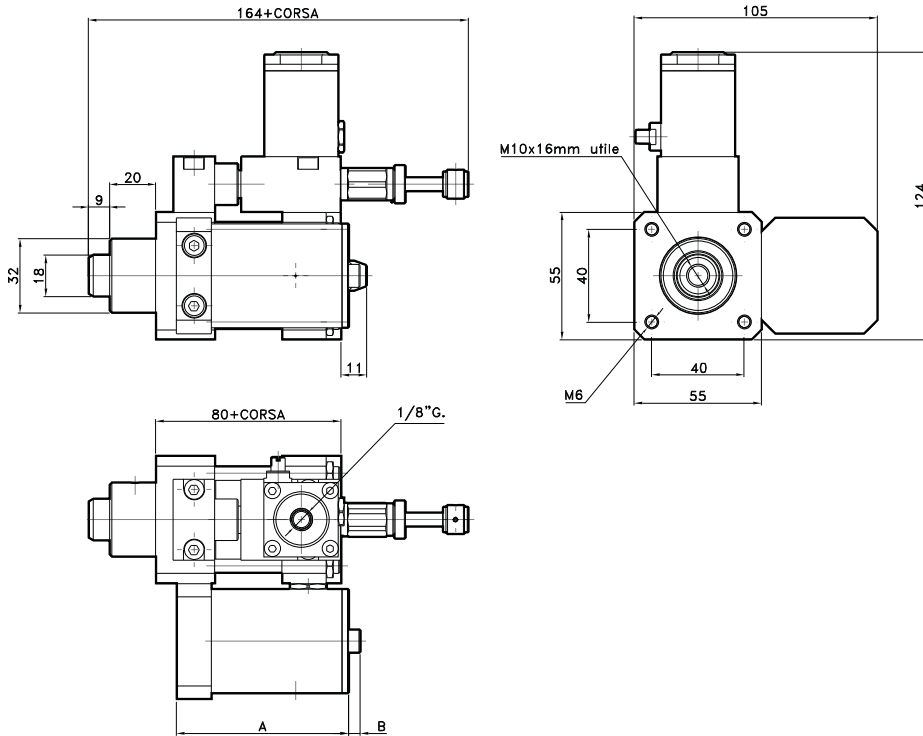
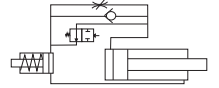

STROKES	A	B max.
< 75	75	25
75÷150	90	39
150÷250	142	65
250÷350	171	87
350÷500	222	125

REGOLAZIONE IN RIENTRO + VALVOLA STOP / INLET REGULATOR + STOP VALVE
CODE: RI300125.corsa/stroke

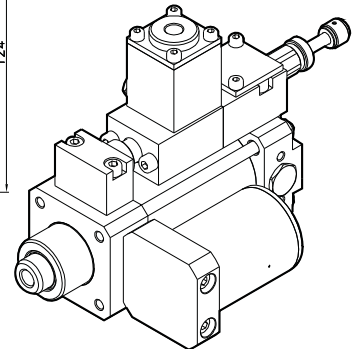
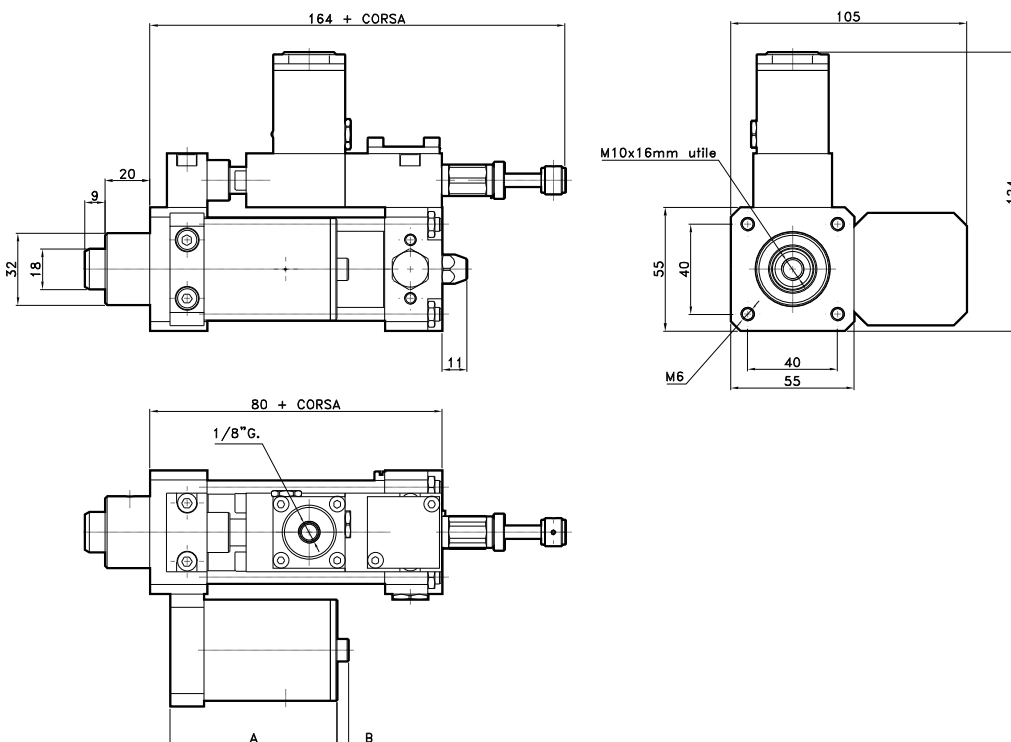
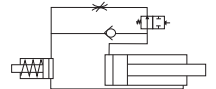

STROKES	A	B max.
< 75	75	25
75÷150	90	39
150÷250	142	65
250÷350	171	87
350÷500	222	125

REGOLAZIONE IN RIENTRO + VALVOLA SKIP + VALVOLA STOP / INLET REGULATOR + SKIP VALVE + STOP VALVE
CODE: RI300126.corsa/stroke

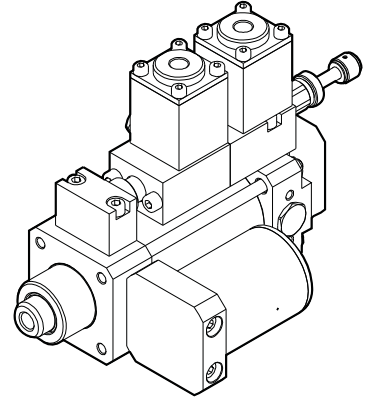
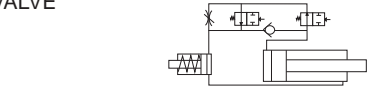
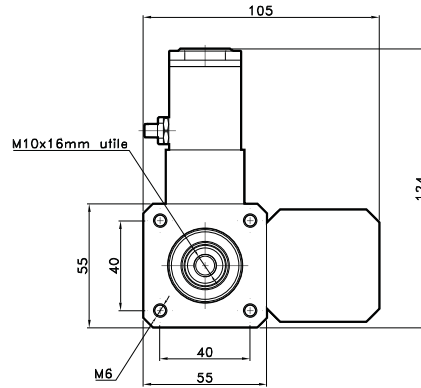
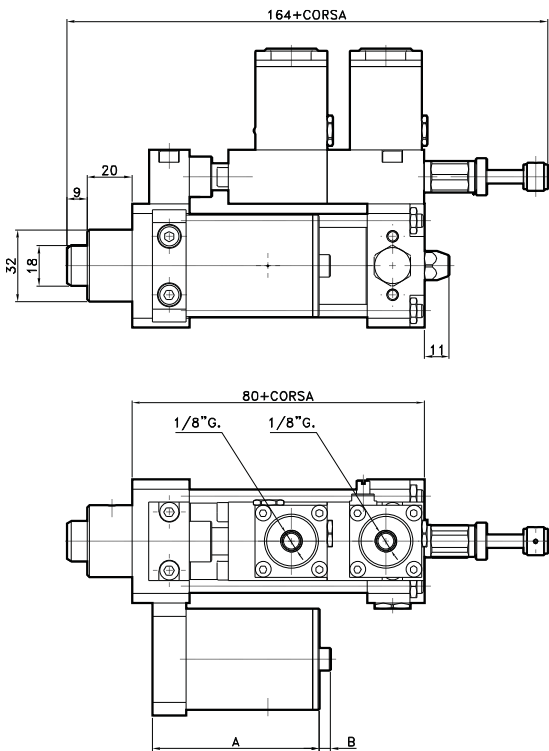

STROKES	A	B max.
< 75	75	25
75÷150	90	39
150÷250	142	65
250÷350	171	87
350÷500	222	125

REGOLAZIONE DOPPIO EFFETTO / DOUBLE ACTING REGULATOR
CODE: RI300132.corsa/stroke

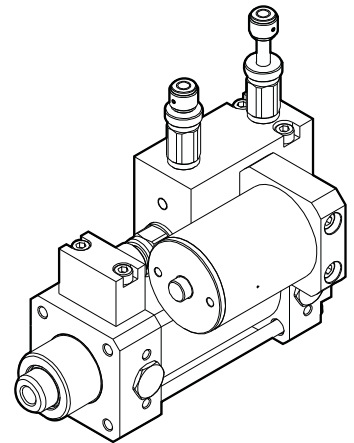
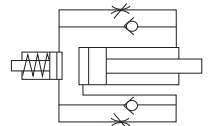
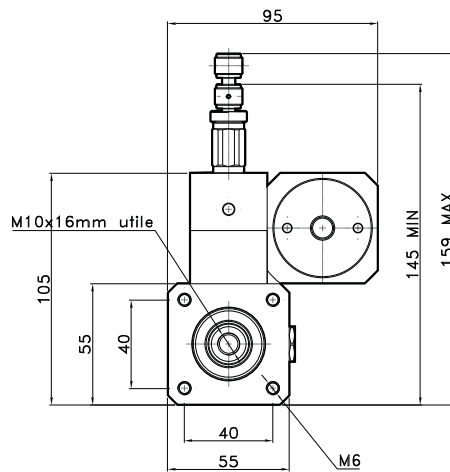
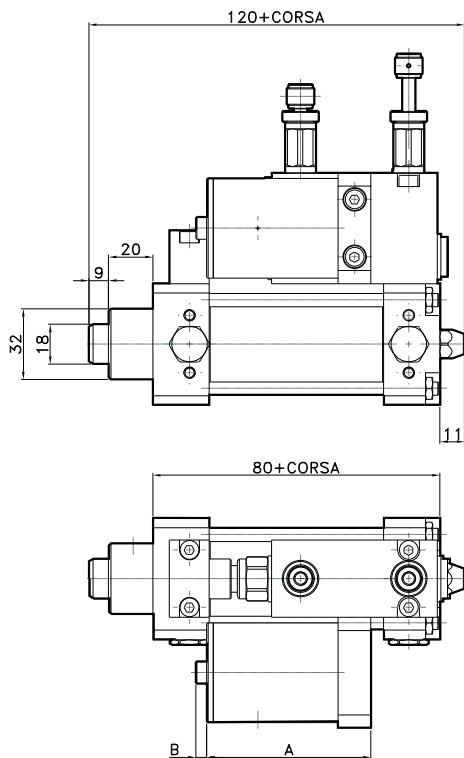

STROKES	A	B max.
< 75	75	25
75÷150	90	39
150÷250	142	65
250÷350	171	87
350÷500	222	125

REGOLAZIONE DOPPIO EFFETTO + VALVOLA SKIP / DOUBLE ACTING REGULATOR + SKIP VALVE
CODE: RI300134.corsa/stroke

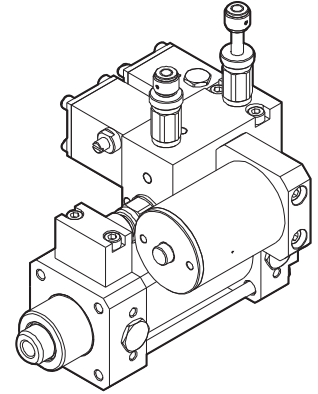
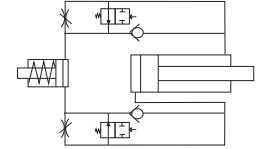
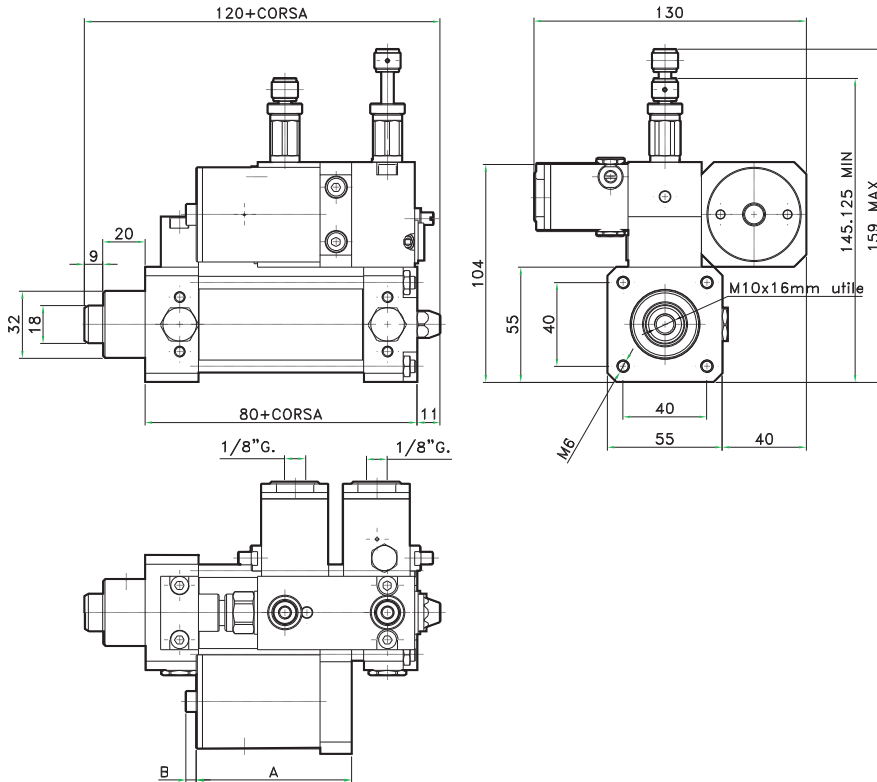

STROKES	A	B max.
< 75	75	25
75÷150	90	39
150÷250	142	65
250÷350	171	87
350÷500	222	125

REGOLAZIONE DOPPIO EFFETTO + VALVOLA STOP / DOUBLE ACTING REGULATOR + STOP VALVE
CODE: RI300135.corsa/stroke

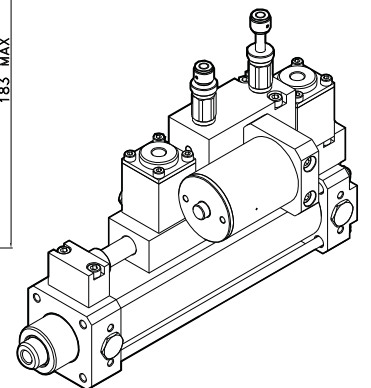
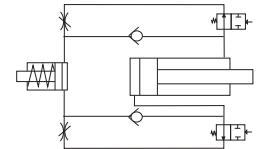
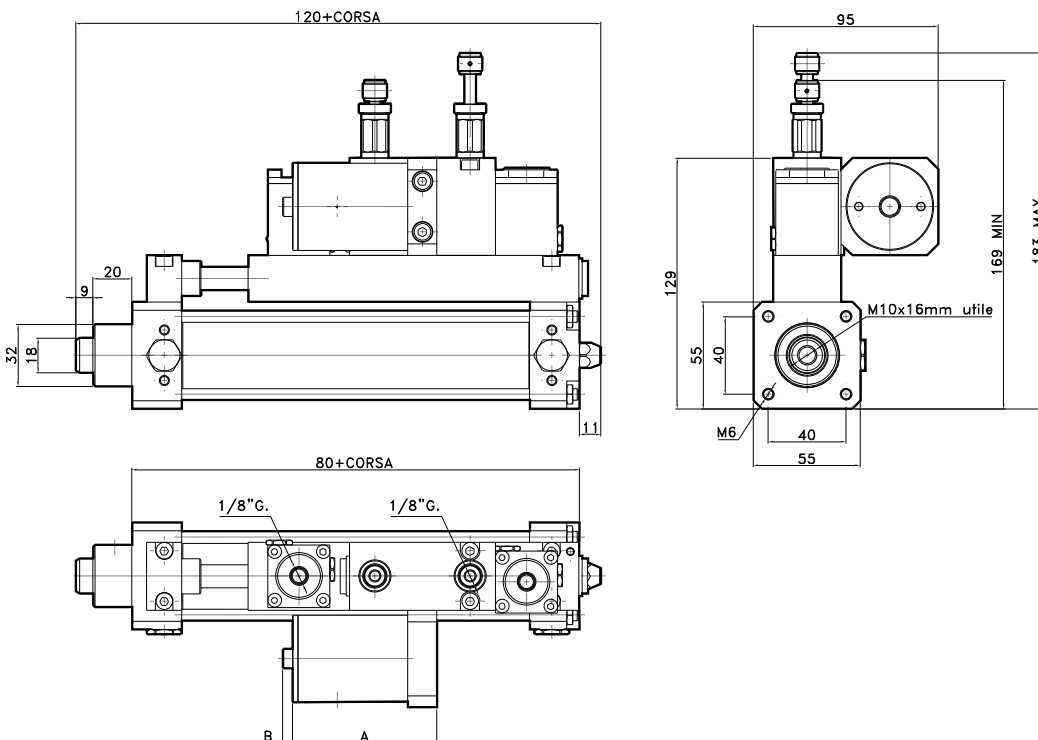

STROKES	A	B max.
150÷250	142	65
250÷350	171	87
350÷500	222	125

REGOLAZIONE DOPPIO EFFETTO + VALVOLA SKIP + VALVOLA STOP / DOUBLE ACTING REGULATOR + SKIP VALVE + STOP VALVE
CODE: RI3001 36.corsa/stroke

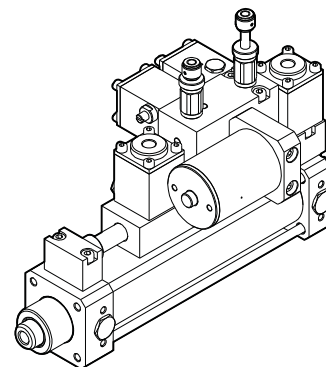
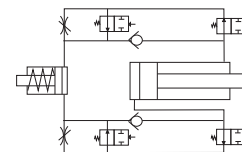
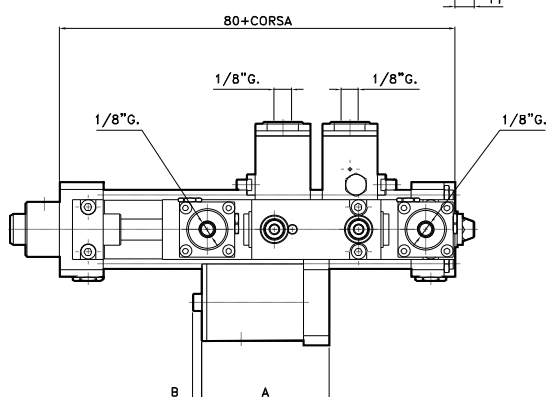
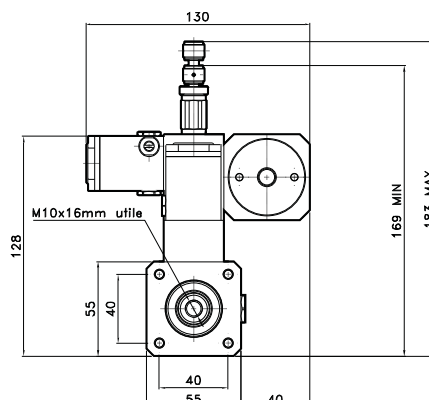
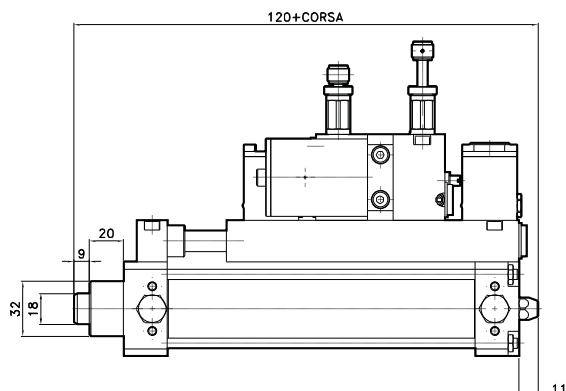

STROKES	A	B max.
150÷250	142	65
250÷350	171	87
350÷500	222	125

MANUTENZIONE / MAINTENANCE

Il regolatore idraulico di velocità è un sistema a circuito chiuso, pertanto non vi sono fattori che possono influire negativamente sul funzionamento. È necessario invece prestare attenzione al livello dell'olio idraulico che non deve mai scendere sotto il livello minimo evidenziato dalla tacca sull'astina del serbatoio supplementare. Se questo avvenisse si creerebbero nel circuito dei fenomeni di cavitazione o peggio delle bolle d'aria che comprometterebbero la capacità di regolazione del sistema. Gli eventuali rabbocchi devono essere effettuati esclusivamente attraverso l'apposita valvola unidirezionale montata sulla testata posteriore tramite una siringa per rabbocco olio.

The hydraulic speed governor is a closed circuit system, and therefore no factors can negatively affect its operation. Be careful with the hydraulic oil level, for it must never drop below the minimum level indicated by the drip stick of the auxiliary tank. Otherwise, cavitation or air bubbles inside the circuit would hinder system regulation. Top-up the oil, if necessary, only through the dedicated unidirectional valve mounted on the rear head, by means of an oil syringe. Excess oil will be ejected through a small drain hole on the tank.

Materiale: Acciaio
Material: Steel

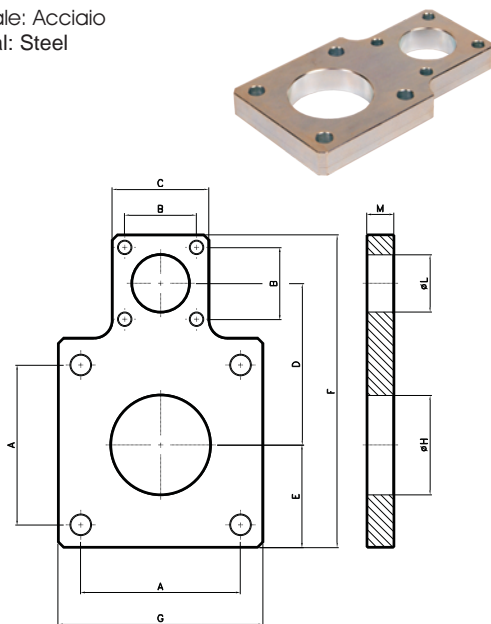

PIASTRA DI COLLEGAMENTO
CONNECTION PLATE

CODE	Ø
AR4179040	40
AR4179050	50
AR4179063	63
AR4179080	80
AR4179100	100

Ø	A	B	C	D	F	G	H	L	M
40	38	40	54	60	114	54	35.5	32	10
50	46.5	40	54	65	124	64	40.5	32	10
63	56.5	40	54	71.5	137	77	45.5	32	10
80	72	40	54	80	154	94	45.5	32	10
100	89	40	54	90	174	114	55.5	32	15

Materiale: Acciaio
Material: Steel



STAFFA DI COLLEGAMENTO STELI
RODS CONNECTOR

CODE	Ø
AR4196040	40
AR4196050	50
AR4196063	63
AR4196080	80
AR4196100	100

Materiale: Acciaio
Material: Steel

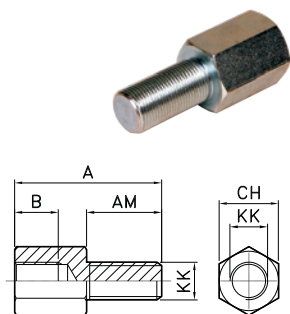

NIPPLO
NIPPLE

CODE	Ø
AR4197040	40
AR4197050	50-63
AR4197080	80-100

Ø	A	AM	B	CH	KK	Peso (g)
40	47	24	14	19	M12x1.25	60
50-63	65	32	19	24	M16x1.5	130
80-100	78	40	24	30	M20x1.5	250



BARRA FILETTATA
THREADED ROD

CODE
AR41981000

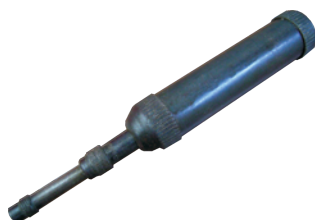

SIRINGA PER IL RABBOCCO OLIO
OIL FILLING SYRINGE

COD
AR4232

CARICO AMMISSIBILE / ADMISSIBLE LOAD

FORZA IN N / FORCE IN N

Taglia (mm) Size (mm)	Ø stelo rod (mm)	superficie utile Working surface	Pressione di lavoro in bar / pressure working in bar									
			1	2	3	4	5	6	7	8	9	10
50	25	spinta / pushing 18.5 cm ²	181	362	544	725	906	1088	1269	1450	1632	1813
		trazione / traction 14.7 cm ²	144	288	433	577	721	865	1010	1154	1298	1443
63	35	spinta / pushing 30.0 cm ²	294	588	883	1177	1472	1766	2060	2355	2649	2944
		Trazione / traction 21.6 cm ²	211	422	633	844	1056	1267	1478	1689	1900	2112

TABELLA DELLE FORZE IN N
FORCE TABLE IN N



TABELLA DEI CONSUMI IN NL (per 1 cm. di corsa)
CYLINDER CONSUMPTION TABLE IN NL (1 cm. of stroke)



COMPONENTI / COMPONENTS

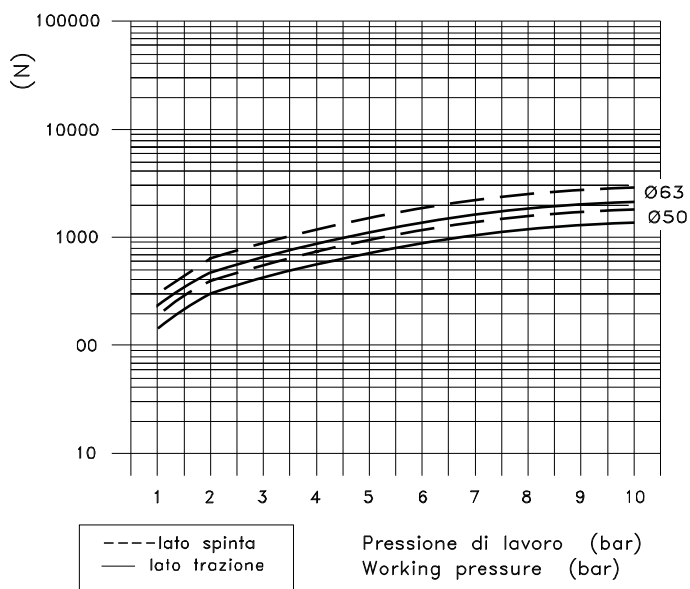
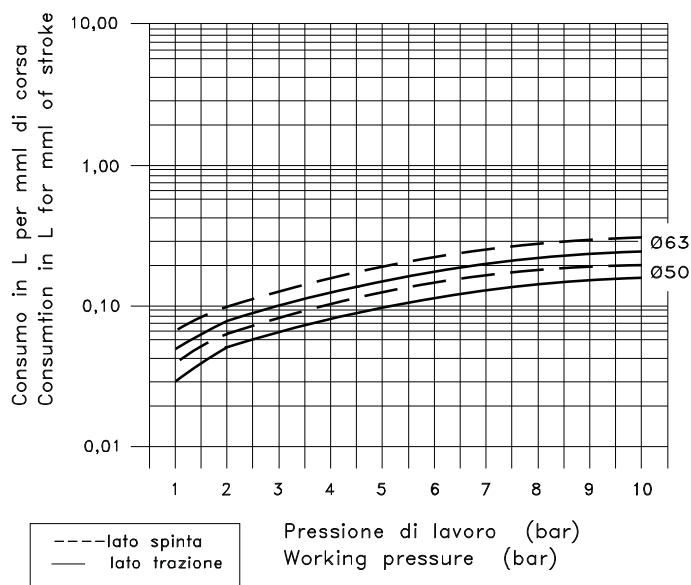
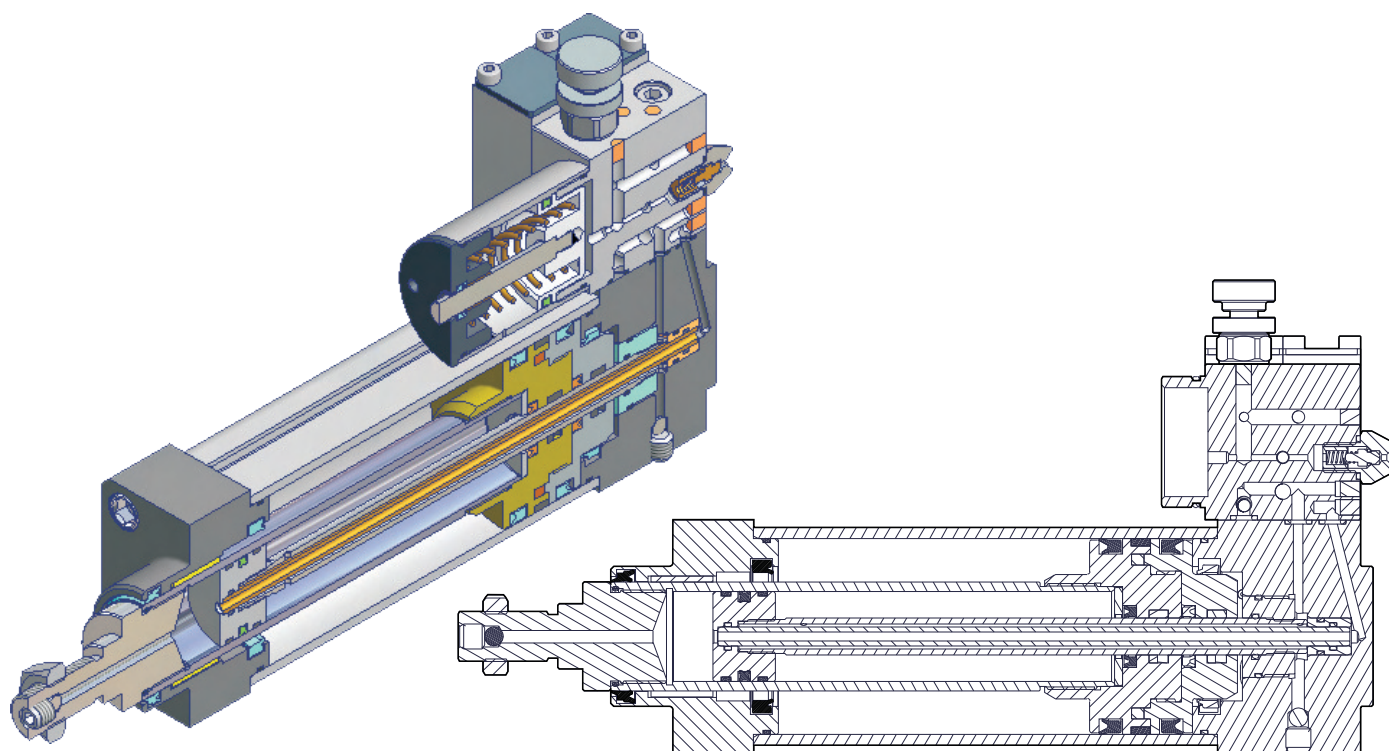

Ø 50

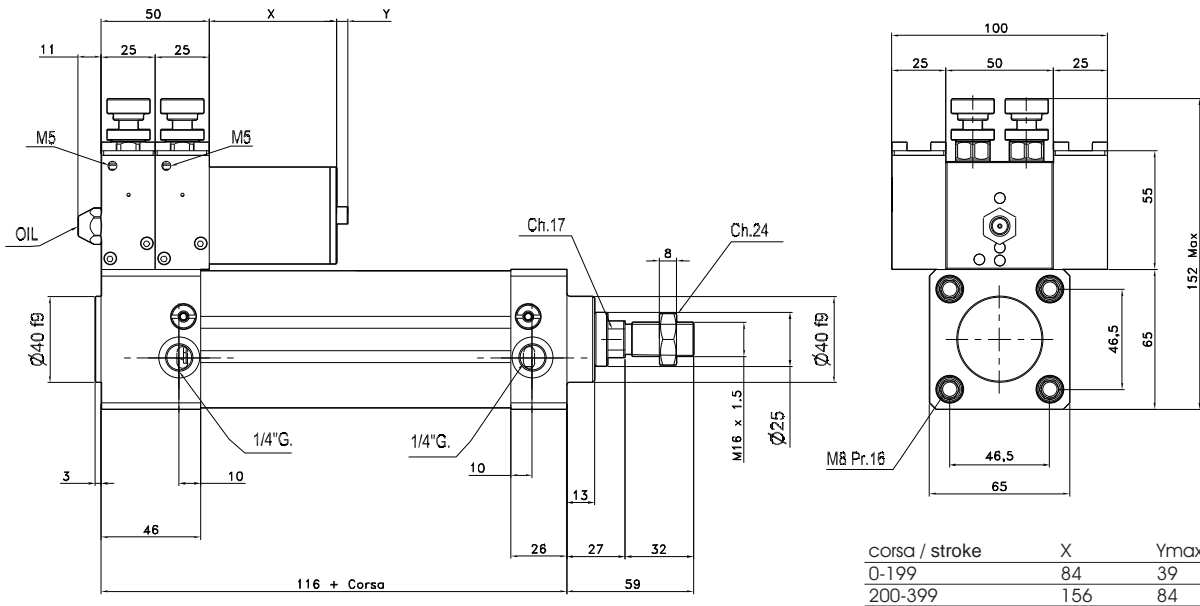

Ø 63

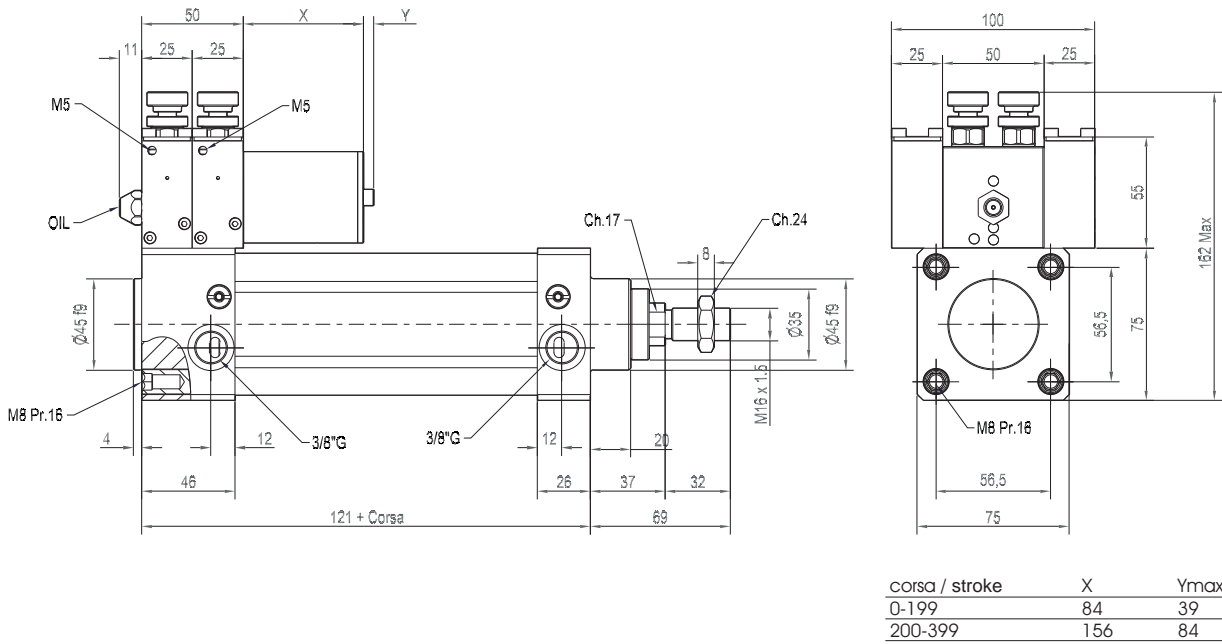

MICROVALVOLE
MICROVALVES



PAGE
2.3

ELETTROPILOTI 15mm
SOLENOID VALVES 15mm



PAGE
2.8

ELETTROPILOTI 10mm
SOLENOID VALVES 10mm



PAGE
2.10

ELETTROVALVOLE A COMANDO DIRETTO
DIRECTLY OPERATED SOLENOID VALVES



PAGE
2.13

ELETTROVALVOLE A COMANDO DIRETTO MODULARE
MODULAR DIRECTLY OPERATED SOLENOID VALVES



PAGE
2.16

VALVOLE AD AZIONAMENTO ELETTRICO
SOLENOID ACTUATED VALVES



PAGE
2.19

SISTEMA DI CONNESSIONE MULTIPOLARE PER SERIE VY
MULTI CONNECTOR SYSTEM FOR VY SERIES

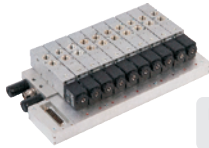

PAGE
2.35

VALVOLE AD AZIONAMENTO PNEUMATICO
PNEUMATIC ACTUATED VALVES



PAGE
2.38

VALVOLE NAMUR
NAMUR VALVES



PAGE
2.46

VALVOLE ISO 5599/1 TAGLIA 1 E 2
ISO 5599/1 VALVES - SIZE 1 AND 2



PAGE
2.50

CONNETTORI E BOBINE
COILS AND CONNECTORS



PAGE
2.32

VALVOLE AD AZIONAMENTO MANUALE
MANUAL ACTUATED VALVES



PAGE
2.55

ATTUATORI DA PANNELLO
ACTUATORS FOR PANEL MOUNTING



PAGE
2.66

VALVOLE AD AZIONAMENTO MECCANICO
MECHANICALLY ACTUATED VALVES



PAGE
2.67

VALVOLE A PEDALE
PEDAL VALVES



PAGE
2.71

REGOLATORI DI FLUSSO
FLOW REGULATORS



PAGE
2.73

REGOLATORI DI FLUSSO
FLOW REGULATORS



PAGE
2.74

VALVOLA SELETRICE
SELECTOR VALVE



PAGE
2.81

VALVOLE DI NON RITORNO
NON RETURN VALVES



PAGE
2.82

VALVOLA A SCARICO RAPIDO
QUICK EXHAUST VALVE



PAGE
2.84

VALVOLE DI BLOCCO
STOP VALVES



PAGE
2.85

PRESSOSTATI
PRESSURE SWITCHES



PAGE
2.87

TRASDUTTORE PNEUMO-ELETTRICO
PRESSURE SWITCHES



PAGE
2.88

VALVOLA A CORSOIO
SLIDE VALVE



PAGE
2.89

RUBINETTI A SFERA
BALL VALVES



PAGE
2.90

RIPARTITORI
MANIFOLDS



PAGE
2.91

SILENZIATORI
AIR SILENCERS



PAGE
2.93



Microvalvole ad otturatore 3/2 NA o NC con svariati sistemi di azionamento, meccanico o manuale e con l'adattatore è possibile montare tutti i tipi di attuatori da pannello e persino accoppiare 2 microvalvole ed ottenere la funzione 5/2 e 5/3.

Microvalves with plug button 3/2 (normally open or normally closed) with several types of acting, mechanical or manual. If combined with the adaptor, it is possible to assemble driving gear mechanic, manual. With the use of the the adaptor all the actuators can be mounted on the panel and it is also possible to combine two microvalves and obtain the function 5/2 and 5/3.

DATI TECNICI / TECHNICAL DATA

Fluido / Fluid	aria con o senza lubrificazione / lubricated or non lubricated air
Pressione di esercizio / Pressure range	2 - 10bar
Temperatura di esercizio / Temperature range	+0 c° - +60c°
Diametro nominale / Nominal orifice	2.5 mm
Portata nominale a 6 bar / Nominal flow rate at 6 bar	100 NI/min

SELEZIONE RAPIDA / FAST SELECT

<u>PULSANTE / BUTTON</u>		<u>PULSANTE PASSA PARETE / PANEL MOUNT TAPPET</u>	
	VM4002013101 VM5002013101 VM4002013601 VM5002013601	lower M5 thread lateral M5 thread lower tube 4 lateral tube 4	VM4002053101 VM5002053101 VM4002053601 VM5002053601
	VM4001013101 VM5001013101 VM4001013601 VM5001013601	lower M5 thread lateral M5 thread lower tube 4 lateral tube 4	VM4001053101 VM5001053101 VM4001053601 VM5001053601
<u>ADATTATORE / ADAPTOR</u>		<u>TASTO / PUSH BUTTON</u>	
	VM4002023101 VM5002023101 VM4002023601 VM5002023601	lower M5 thread lateral M5 thread lower tube 4 lateral tube 4	VM4002063101 VM5002063101 VM4002063601 VM5002063601
	VM4001023101 VM5001023101 VM4001023601 VM5001023601	lower M5 thread lateral M5 thread lower tube 4 lateral tube 4	VM4001063101 VM5001063101 VM4001063601 VM5001063601
<u>LEVA RULLO / ROLLER LEVER</u>		<u>ADATTATORE / ADAPTOR</u>	
	VM4002033101 VM5002033101 VM4002033601 VM5002033601	lower M5 thread lateral M5 thread lower tube 4 lateral tube 4	VM4000025101 VM5000025101 VM4000025601 VM5000025601
	VM4001033101 VM5001033101 VM4001033601 VM5001033601	lower M5 thread filetto M5 lateral lower tube 4 lateral tube 4	VM4000026121 VM5000026121 VM4000026621 VM5000026621
<u>LEVA UNIDIREZIONALE / UNI-DIRECTIONAL LEVER</u>		<u>ADATTATORE / ADAPTOR</u>	
	VM4002043101 VM5002043101 VM4002043601 VM5002043601	lower M5 thread lateral M5 thread lower tube 4 lateral tube 4	VM4000026131 VM5000026131 VM4000026631 VM5000026631
	VM4001043101 VM5001043101 VM4001043601	lower M5 thread lateral M5 thread lower tube 4	

PULSANTE - FILETTO M5 INFERIORE
BUTTON - LOWER M5 THREAD

VM4002013101 3/2 NC
VM4001013101 3/2 NA / NO

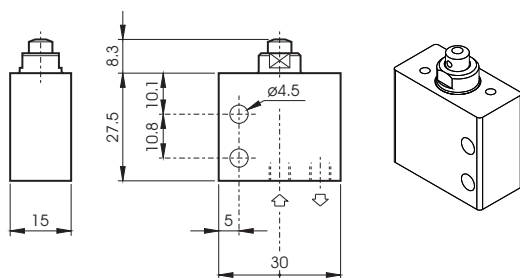

PULSANTE - FILETTO M5 LATERALE
BUTTON - LATERAL M5 THREAD

VM5002013101 3/2 NC
VM5001013101 3/2 NA / NO

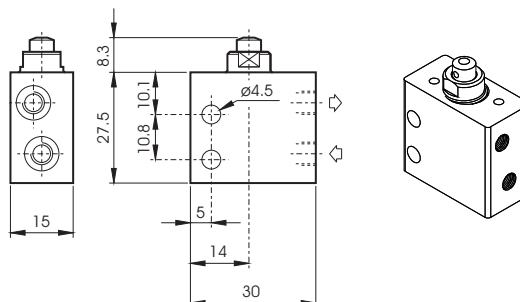

PULSANTE - TUBO 4 INFERIORE
BUTTON - LOWER TUBE 4

VM4002013601 3/2 NC
VM4001013601 3/2 NA / NO

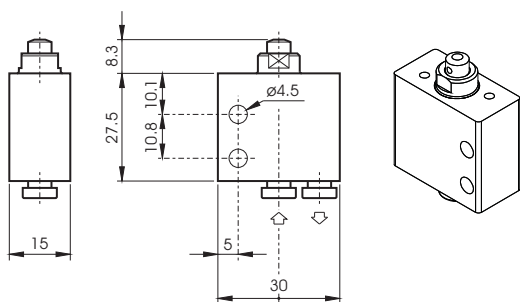

PULSANTE - TUBO 4 LATERALE
BUTTON - LATERAL TUBE 4

VM5002013601 3/2 NC
VM5001013601 3/2 NA / NO

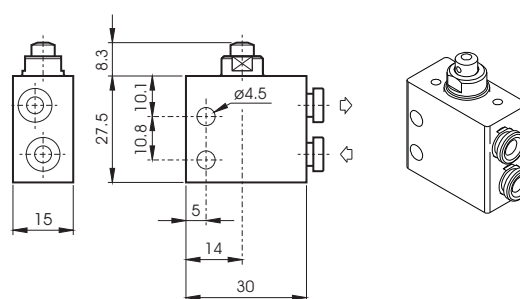

ADATTATORE - FILETTO M5 INFERIORE
ADAPTOR - LOWER M5 THREAD

VM4002023101 3/2 NC
VM4001023101 3/2 NA / NO

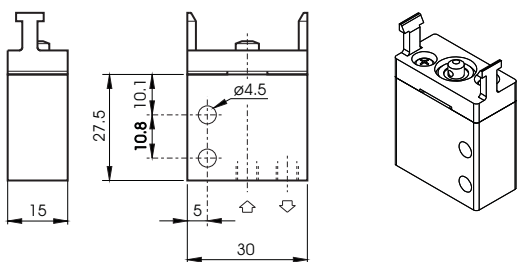

ADATTATORE - FILETTO M5 LATERALE
ADAPTOR - LATERAL M5 THREAD

VM5002023101 3/2 NC
VM5001023101 3/2 NA / NO

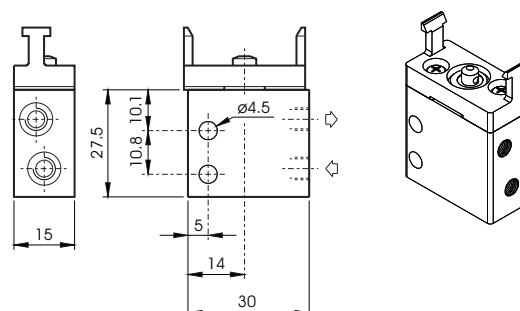

ADATTATORE - TUBO 4 INFERIORE
ADAPTOR - LOWER TUBE 4

VM4002023601 3/2 NC
VM4001023601 3/2 NA / NO

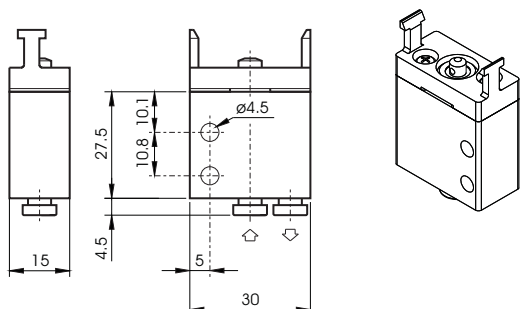

ADATTATORE - TUBO 4 LATERALE
ADAPTOR - LATERAL TUBE 4

VM5002023601 3/2 NC
VM5001023601 3/2 NA / NO

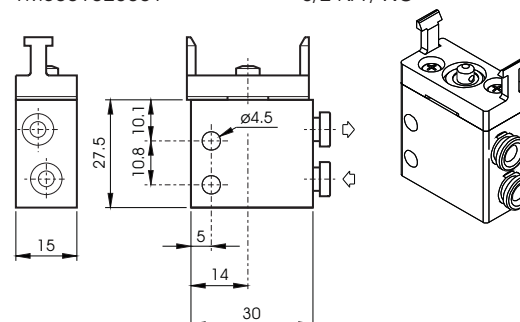

LEVA RULLO - FILETTO M5 INFERIORE
ROLLER LEVER - LOWER M5 THREAD

VM4002033101 3/2 NC
VM4001033101 3/2 NA / NO

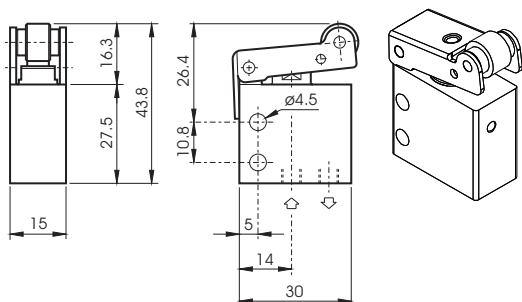

LEVA RULLO - FILETTO M5 LATERALE
ROLLER LEVER - LATERAL M5 THREAD

VM5002033101 3/2 NC
VM5001033101 3/2 NA / NO

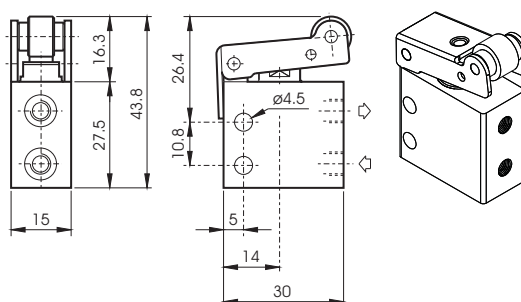

LEVA RULLO - TUBO 4 INFERIORE
ROLLER LEVER - LOWER TUBE 4

VM4002033601 3/2 NC
VM4001033601 3/2 NA / NO

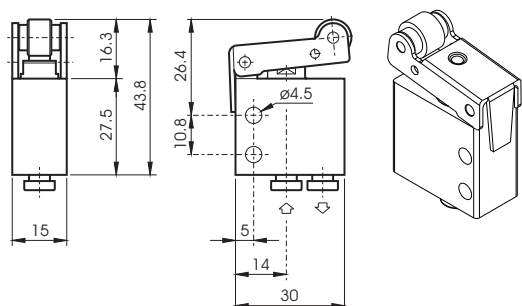

LEVA RULLO - TUBO 4 LATERALE
ROLLER LEVER - LATERAL TUBE 4

VM5002033601 3/2 NC
VM5001033601 3/2 NA / NO

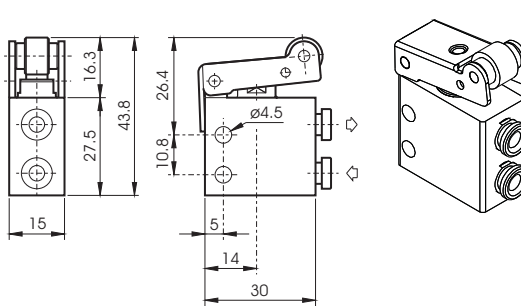

LEVA UNIDIREZIONALE - FILETTO M5 INFERIORE
UNI-DIRECTIONAL LEVER - LOWER M5 THREAD

VM4002043101 3/2 NC
VM4001043101 3/2 NA / NO

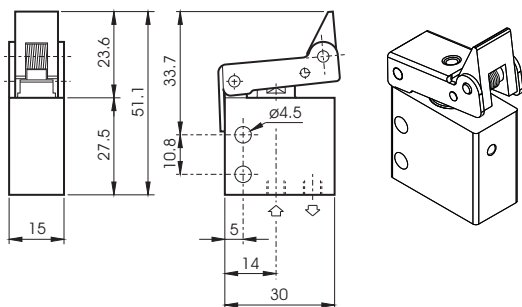

LEVA UNIDIREZIONALE - FILETTO M5 LATERALE
UNI-DIRECTIONAL LEVER - LATERAL M5 THREAD

VM5002043101 3/2 NC
VM5001043101 3/2 NA / NO

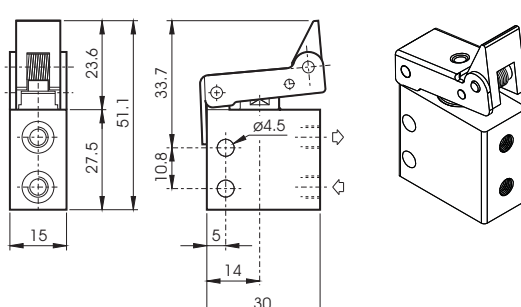

LEVA UNIDIREZIONALE - TUBO 4 INFERIORE
UNI-DIRECTIONAL LEVER - LOWER TUBE 4

VM4002043601 3/2 NC
VM4001043601 3/2 NA / NO

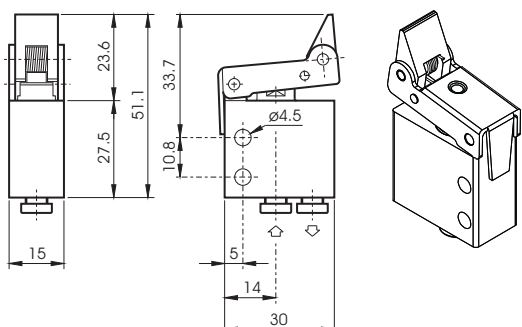

LEVA UNIDIREZIONALE - TUBO 4 LATERALE
UNI-DIRECTIONAL LEVER - LATERAL TUBE 4

VM5002043601 3/2 NC
VM5001043601 3/2 NA / NO

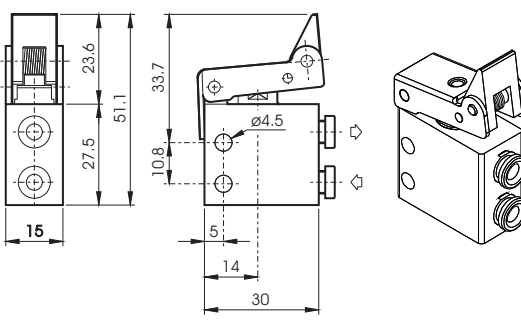

PULSANTE PASSA PARETE - FILETTO M5 INFERIORE
PANEL MOUNT TAPPET - LOWER M5 THREAD

VM4002053101 3/2 NC
VM4001053101 3/2 NA / NO

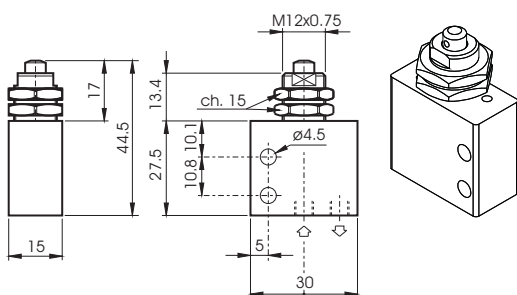

PULSANTE PASSA PARETE - FILETTO M5 LATERALE
PANEL MOUNT TAPPET - LATERAL M5 THREAD

VM5002053101 3/2 NC
VM5001053101 3/2 NA / NO

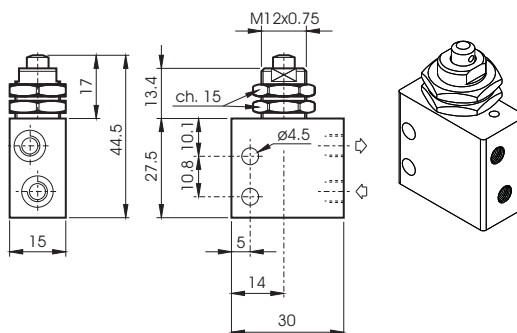

PULSANTE PASSA PARETE - TUBO 4 INFERIORE
PANEL MOUNT TAPPET - LOWER TUBE 4

VM4002053601 3/2 NC
VM4001053601 3/2 NA / NO

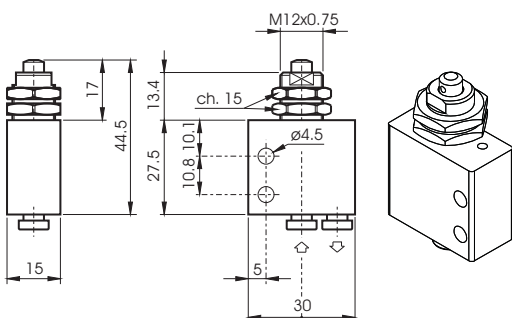

PULSANTE PASSA PARETE - TUBO 4 LATERALE
PANEL MOUNT TAPPET - LATERAL TUBE 4

VM5002053601 3/2 NC
VM5001053601 3/2 NA / NO

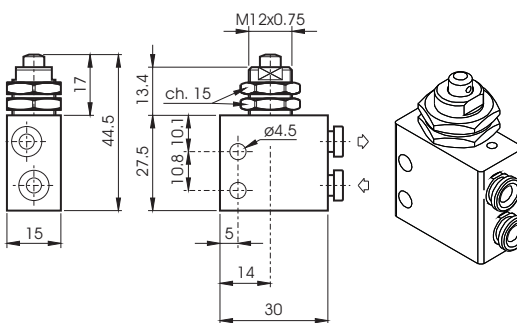

TASTO - FILETTO M5 INFERIORE
PUSH BUTTON - LOWER M5 THREAD

VM4002063101 3/2 NC
VM4001063101 3/2 NA / NO

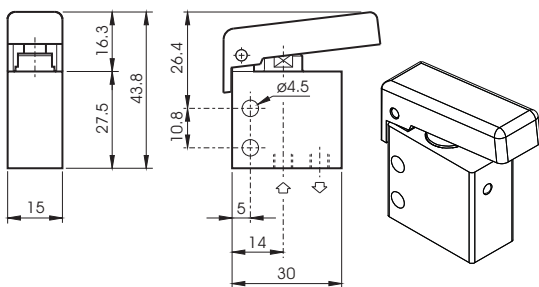

TASTO - FILETTO M5 LATERALE
PUSH BUTTON - LATERAL M5 THREAD

VM5002063101 3/2 NC
VM5001063101 3/2 NA / NO

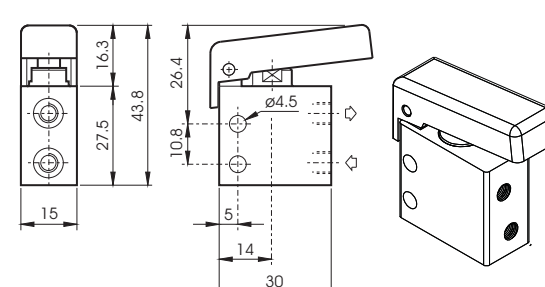

TASTO - TUBO 4 INFERIORE
PUSH BUTTON - LOWER TUBE 4

VM4002063601 3/2 NC
VM4001063601 3/2 NA / NO

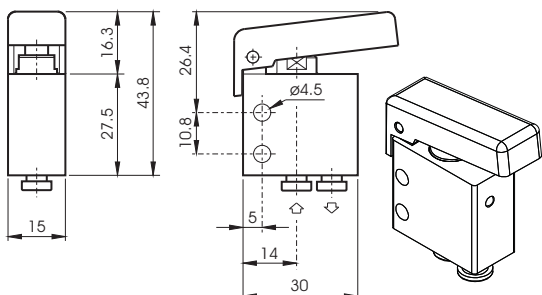

TASTO - TUBO 4 LATERALE
PUSH BUTTON - LATERAL TUBE 4

VM5002063601 3/2 NC
VM5001063601 3/2 NA / NO

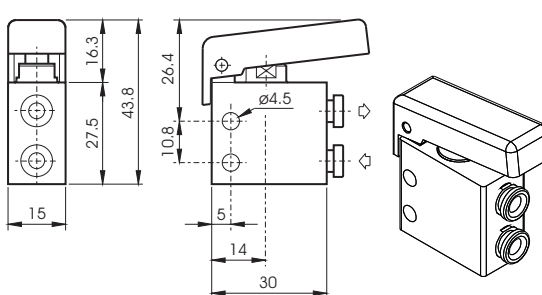

ADATTATORE - FILETTO M5 INFERIORE
ADAPTOR - LOWER M5 THREAD

VM4000025101 5/2
VM4000026121 5/3 CA / CO
VM4000026131 5/3 CP

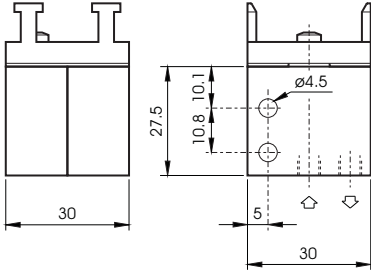

ADATTATORE - FILETTO M5 LATERALE
ADAPTOR - LATERAL M5 THREAD

VM5000025101 5/2
VM5000026121 5/3 CA / CO
VM5000026131 5/3 CP

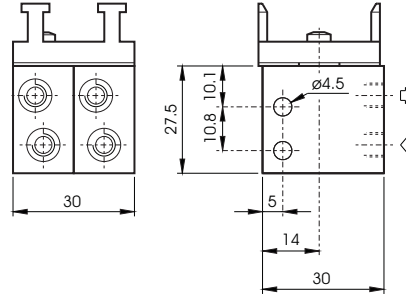

ADATTATORE - TUBO 4 INFERIORE
ADAPTOR - LOWER TUBE 4

VM4000025601 5/2
VM4000026621 5/3 CA / CO
VM4000026631 5/3 CP

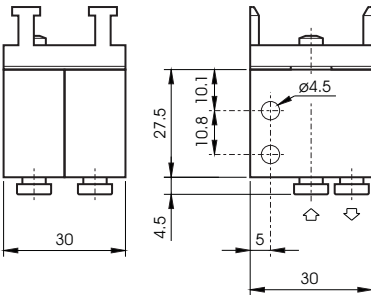

ADATTATORE - TUBO 4 LATERALE
ADAPTOR - LATERAL TUBE 4

VM5000025601 5/2
VM5000026621 5/3 CA / CO
VM5000026631 5/3 CP

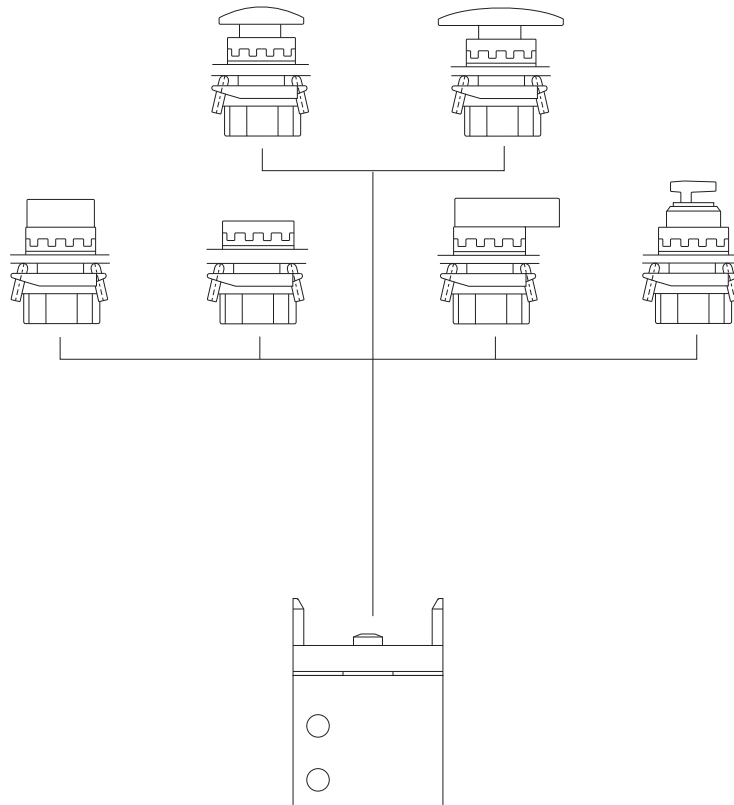
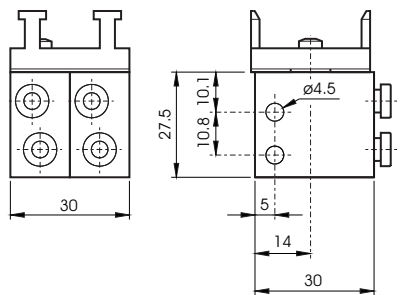

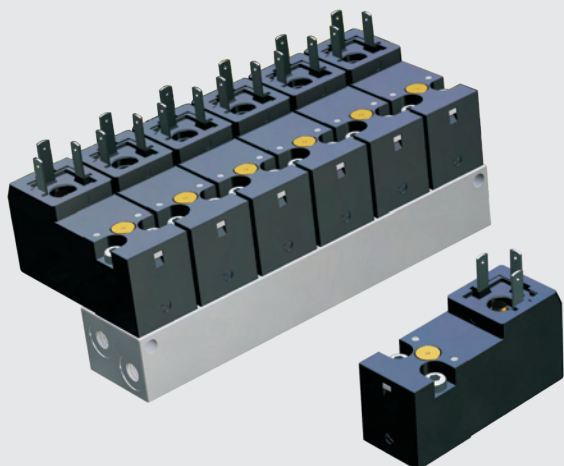

Gli elettropiloti a comando diretto sono particolarmente indicati per montaggio su basi multiple oppure su basi singole, permettono un basso assorbimento di energia ed hanno un piccolo comando monostabile per intervento manuale.

The solenoid valves directly controlled are suitable for assembling on multiple or single bases; they have a low consumption of energy and have a small monostable control for an eventual manual intervention.

DATI TECNICI / TECHNICAL DATA

Tipo / Type	3/2 NC
Pressione massima di esercizio / Max operating pressure	10 bar
Temperatura max di esercizio / Max working temperature	+50 C°
Portata / flow rate	30 NI/min
Diametro nominale / Nominal orifice	1,1mm
Durata cicli / Life time	100 millions cycles
Tolleranza di tensione / Tension tolerance	-10% - +15%
Tempo di risposta / Response time	10ms
Inserimento / duty cycle	ED 100%
Consumo a regime / rated power consumption	DC: 2W - AC: 1.3VA
Protezione / protection	IP 51

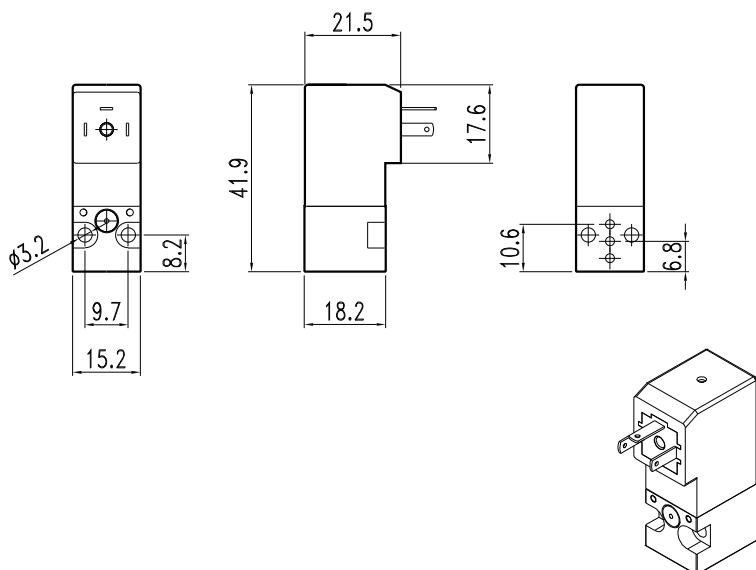

CODE	DES.
EP3112	3/2 NC 12V DC
EP3122	3/2 NC 24V DC
EP3132	3/2 NC 24V AC
EP3142	3/2 NC 110V AC
EP3152	3/2 NC 220V AC

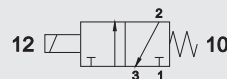

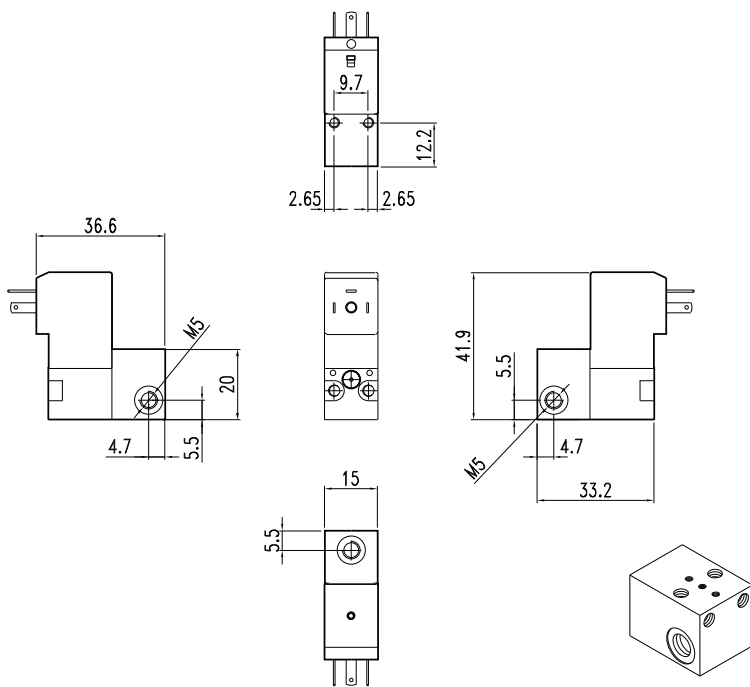

BASE SINGOLA
SINGLE MANIFOLD

CODE _____
SB402101 _____

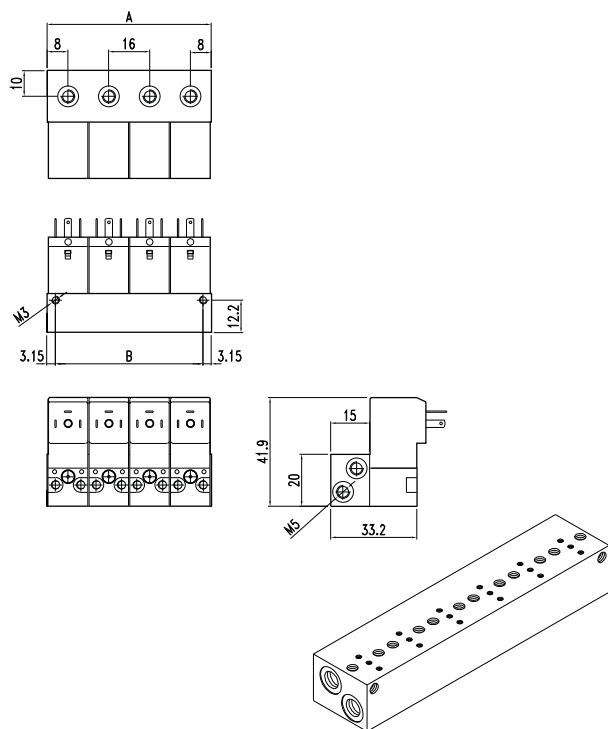

BASE MULTIPLA
MANIFOLD

CODE	POS.	A	B
SB402102	2	32	25.7
SB402103	3	48	41.7
SB402104	4	64	57.7
SB402105	5	80	73.7
SB402106	6	96	89.7
SB402107	7	112	105.7
SB402108	8	128	121.7
SB402109	9	144	137.7
SB402110	10	160	153.7

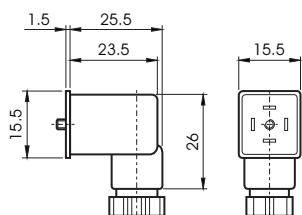

CONNETTORI
CONNECTORS

CODE	DES.
VX0020	STANDARD
VX0021	LED 24V
VX0022	LED 110V
VX0023	LED 220V
VX0024	LED VDR 24V
VX0025	LED VDR 110V
VX0026	LED VDR 220V

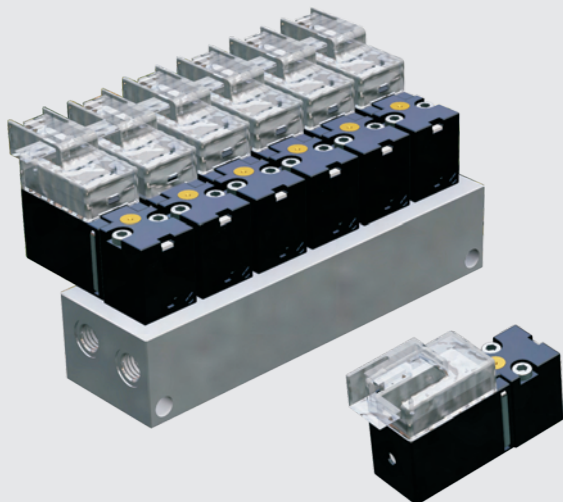

Gli elettropiloti a comando diretto sono particolarmente indicati per montaggio su basi multiple oppure su basi singole, permettono un basso assorbimento di energia ed hanno un piccolo comando monostabile per intervento manuale.

The solenoid valves directly controlled are suitable for assembling on multiple or single bases; they have a low consumption of energy and have a small monostable control for an eventual manual intervention.

DATI TECNICI / TECHNICAL DATA

Tipo / Type	3/2 NC
Pressione massima di esercizio / Max operating pressure	0 - 8 bar
Temperatura max di esercizio / Max working temperature	-5 C° +50 C°
Portata a 6 bar e Δp 1 bar / flow rate to 6 bar and Δp 1 bar	17 NI/min
Diametro nominale / Nominal orifice	0,8 mm
Durata cicli / Life time	50 millions cycles
Tolleranza di tensione / Tension tolerance	-10% - +10%
Tempo di risposta / Response time	10ms
Inserimento / duty cycle	ED 100%
Voltaggio / voltage	12-24 V DC
Consumo a regime / rated power consumption	1W
Protezione / protection	IP 40

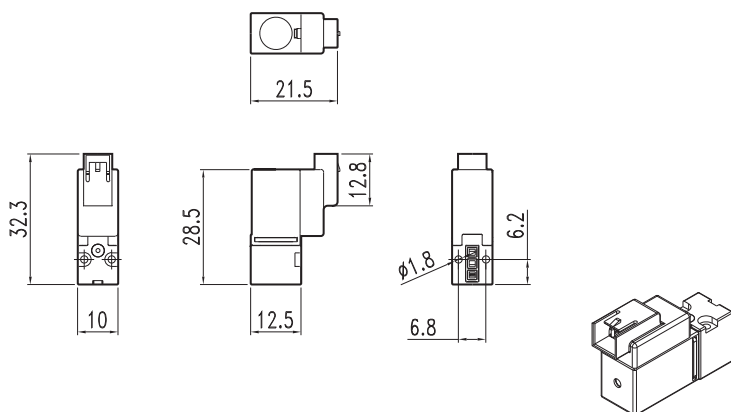

3/2 NC - CONNETTORE INFERIORE
3/2 NC - LOWER CONNECTOR

CODE
EP30221

24V DC

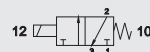

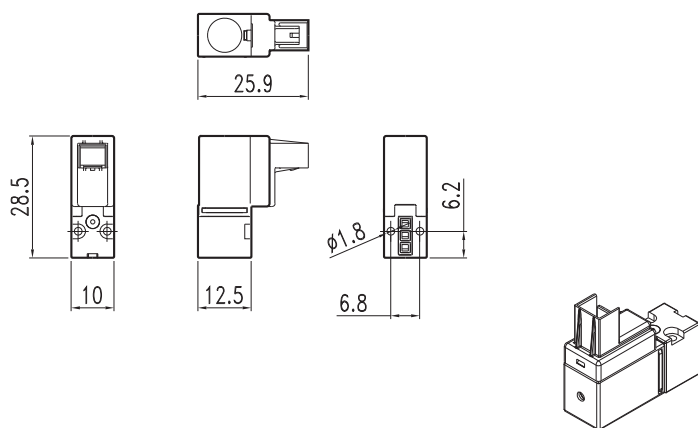

3/2 NC - CONNETTORE LATERALE
3/2 NC - LATERALE CONNECTOR

CODE
EP30220

24V DC

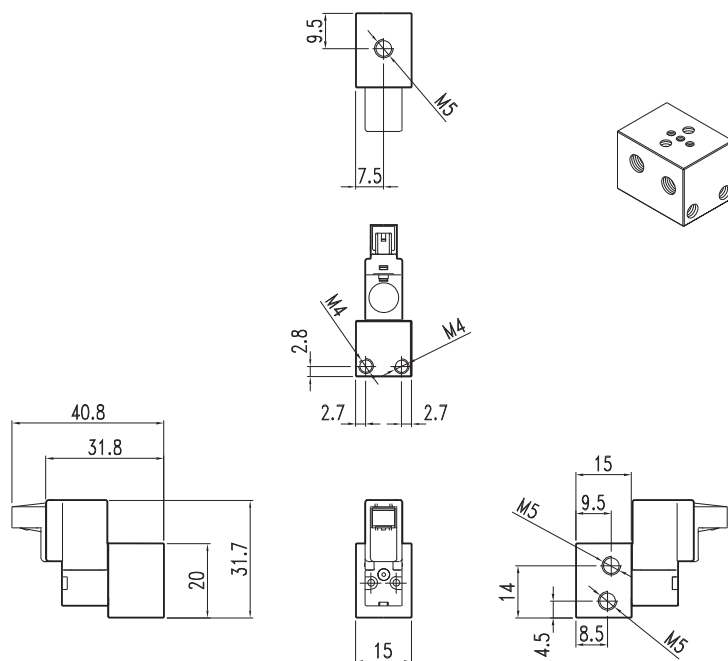

BASE SINGOLA
SINGLE MANIFOLD

CODE
SB406101

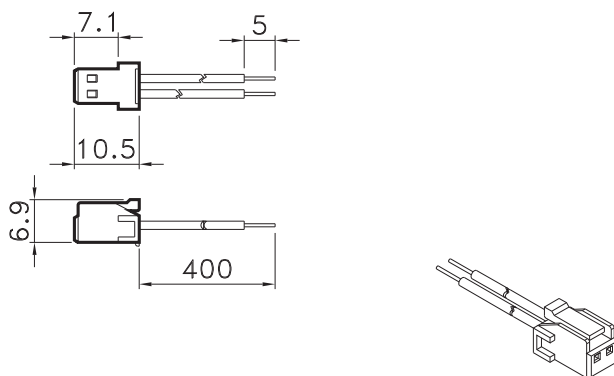

CONNETTORE
CONNECTOR

CODE
VX0028

400mm

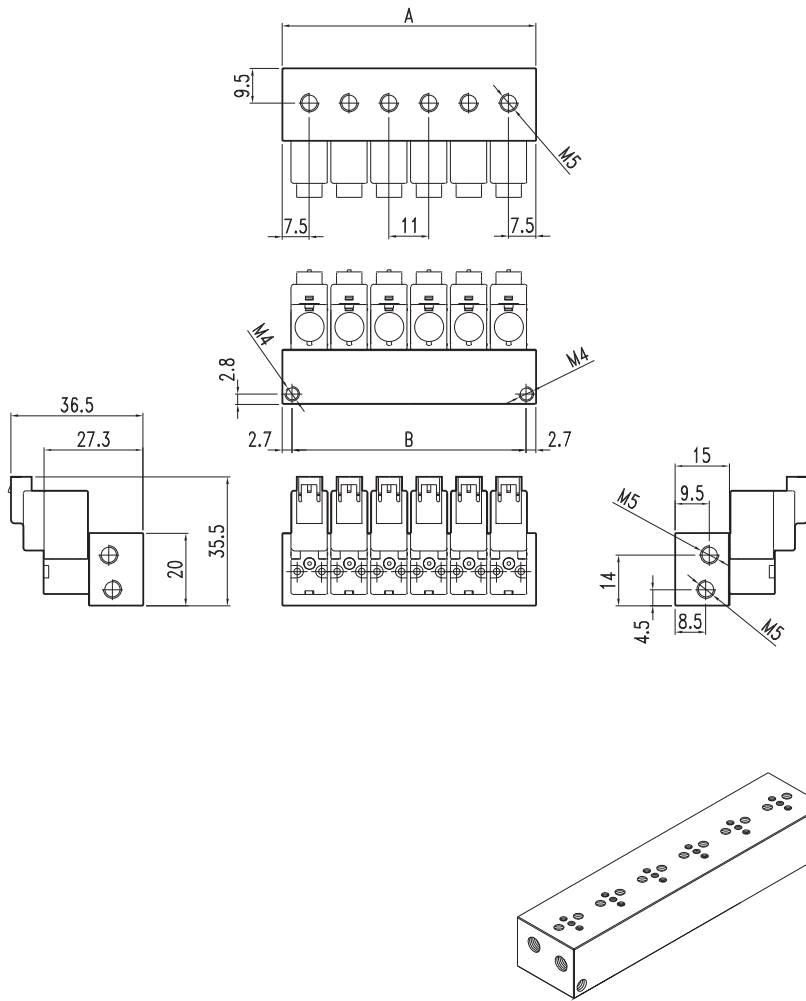

BASE MULTIPLA
MANIFOLD

CODE	POS.	A	B
SB406102	2	26	20,6
SB406103	3	37	31,6
SB406104	4	48	42,6
SB406105	5	59	53,6
SB406106	6	70	64,6
SB406107	7	81	75,6
SB406108	8	92	86,6
SB406109	9	103	97,6
SB406110	10	114	108,6



Gli elettropiloti a comando diretto sono particolarmente indicati per montaggio in qualsiasi posizione grazie alle dimensioni molto contenute. Sono disponibili nelle taglie M5, 1/8 e 1/4 nelle funzioni 3/2 NC (norm.chiuso) o NA, (norm.aperto).

The direct control solenoid valves are particularly indicated for the assembling in any position thanks to their small dimensions. They are available in sizes M5, 1/8 and 1/4 in the functions 3/2 NC (norm.close) o NO, (norm. open).

DATI TECNICI / TECHNICAL DATA

Fluido / Fluid	aria con o senza lubrificazione / lubricated or non lubricated air
Tipo / Type	3/2 NC NA / 3/2 NC NO
Pressione massima di esercizio / Max operating pressure	10 bar
Temperatura max di esercizio / Max working temperature	-10C° + 50 C°
Portata a 6 bar, $\dot{A}p$ 1bar / flow at 6 bar, $\dot{A}p$ 1bar	M5: 40 NI/min - 1/8: 50NI/min - 1/4: 50NI/min
Diametro nominale / Nominal orifice	1,1mm
Tolleranza di tensione / Tension tolerance	-10% - +15%
Tempo di risposta / Response time	10ms
Inserimento / duty cycle	ED 100%
Consumo a regime / rated power consumption	DC: 3W - AC: 5VA
Tensione bobine / Coils tension	24VDC - 24VAC - 110VAC - 220VAC 50/60Hz
Protezione / protection	IP 67

COMPONENTI / COMPONENTS

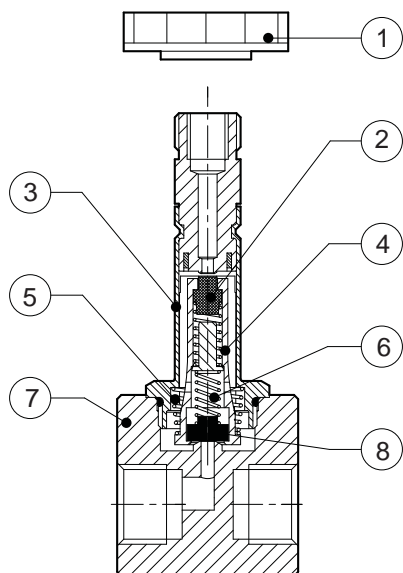

pos.	description	material
1	dado / nut	plastica / plastic
2	guarnizione / seal	NBR
3	corpo / body	ottone / brass
4	nucleo mobile / mobile core	ottone / brass
5	molla / spring	acciaio / steel
6	molla / spring	acciaio / steel
7	corpo valvola / body valve	alluminio / aluminium
8	guarnizione / seal	NBR

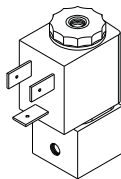
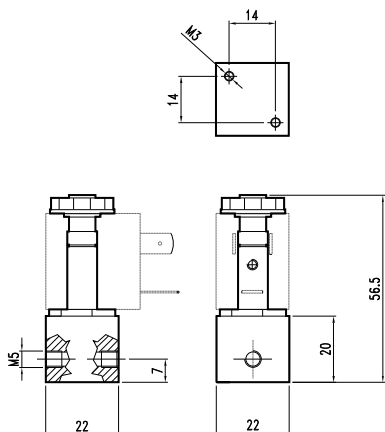

M5 3/2 NC
M5 3/2 NC

CODE: VD3122

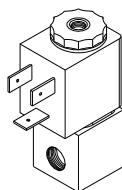
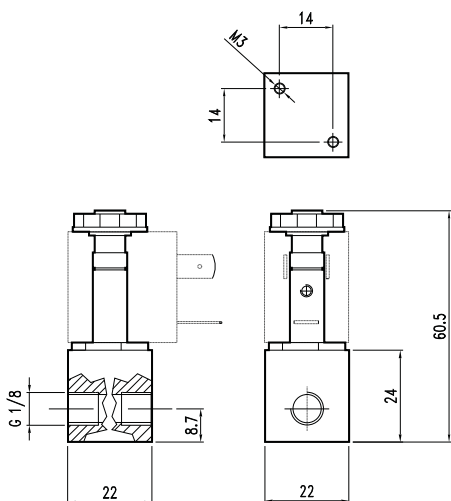
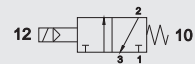

1/8 3/2 NC
1/8 3/2 NC

CODE: VD3222

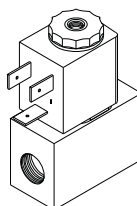
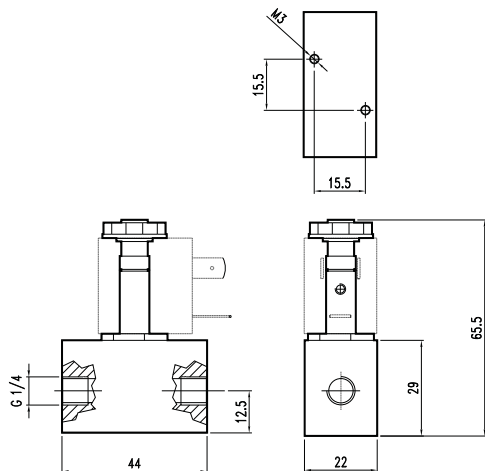
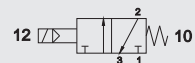

1/4 3/2 NC
1/4 3/2 NC

CODE: VD3322

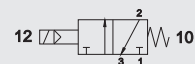

1/4 3/2 NA
1/4 3/2 NO

CODE: VD3321

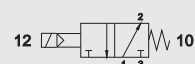

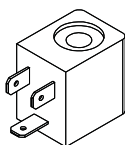
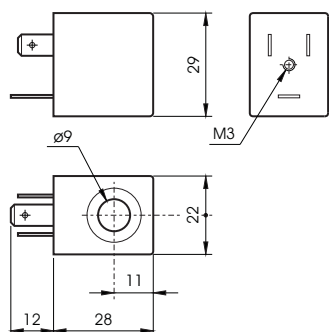

BOBINE
COILS

CODE	Tensione Tension	Assorbimento a regime Rated	Power di spunto Inrush
BO4011024	24 VDC	3W	
BO4012024	24 VAC	5VA	7,5VA
BO4012110	110 VAC	5VA	7,5VA
BO4012220	220 VAC	5VA	7,5VA

CARATTERISTICHE TECNICHE / TECHNICAL SPECIFICATIONS

Tolleranza di tensione / Tension tolerance	+10%
Protezione con connettore / Protection with connector	IP65
Temperatura max di esercizio / Max working temperature	+50 C°
Inserimento / Duty cycle	ED 100%

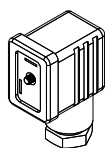
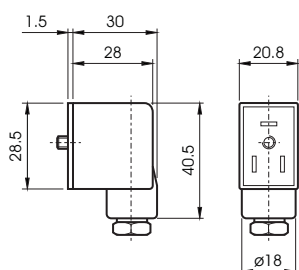

CONNETTORI
CONNECTORS

CODE	
AR40696	STANDARD
VX0014	LED 24V
VX0015	LED 110V
VX0016	LED 220V
VX0017	LED+VDR di protezione 24V
VX0018	LED+VDR di protezione 110V
VX0019	LED+VDR di protezione 220V

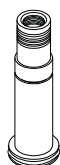
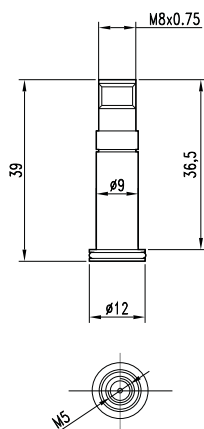

ELETTROPILOTA
SOLENOID PILOT

CODE	
EP43603	STANDARD

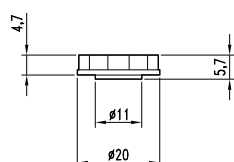
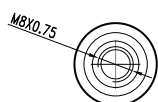

DADO
NUT

CODE	
DA42937	STANDARD

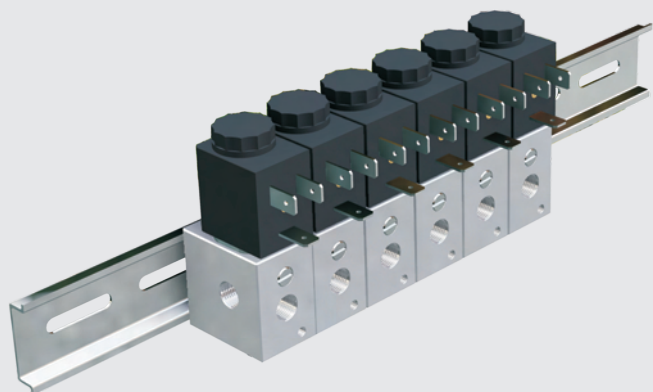

Le elettrovalvole a comando diretto modulari, consentono il montaggio universale delle valvole, su pezzo fisso o su barra Omega DIN EN 50022. Inoltre garantiscono tempi di risposta molto veloci e la possibilità di intervenire manualmente sulla vite bistabile. Sono disponibili nella versione 3/2 NC (norm.chiuso) o NA, (norm.aperto) ed hanno il filetto da 1/8.

The electro valves with modular assembling system, on molded piece or on Omega bar DIN EN 50022. They grant quick reaction time and the possibility to manually act on the bi-stable screw. They are available in the version 3/2 NC (norm.close) or NO, (norm. open) and the thread is 1/8.

DATI TECNICI / TECHNICAL DATA

Fluido / Fluid	aria con o senza lubrificazione / lubricated or non lubricated air
Tipo / Type	3/2 NC NA / 3/2 NC NO
Pressione massima di esercizio / Max operating pressure	10 bar
Temperatura max di esercizio / Max working temperature	10C° + 50 C°
Portata a 6 bar, Δp 1 bar / flow at 6 bar, Δp 1 bar	50 NI/min
Diametro nominale / Nominal orifice	1,1mm
Tolleranza di tensione / Tension tolerance	-10% - +15%
Tempo di risposta / Response time	10ms
Inserimento / duty cycle	ED 100%
Consumo a regime / rated power consumption	DC: 3W - AC: 5VA
Tensione bobine / Coils tension	24VDC - 24VAC - 110VAC - 220VAC 50/60Hz
Protezione / protection	IP 67

SISTEMA DI MONTAGGIO / ASSEMBLY SYSTEM

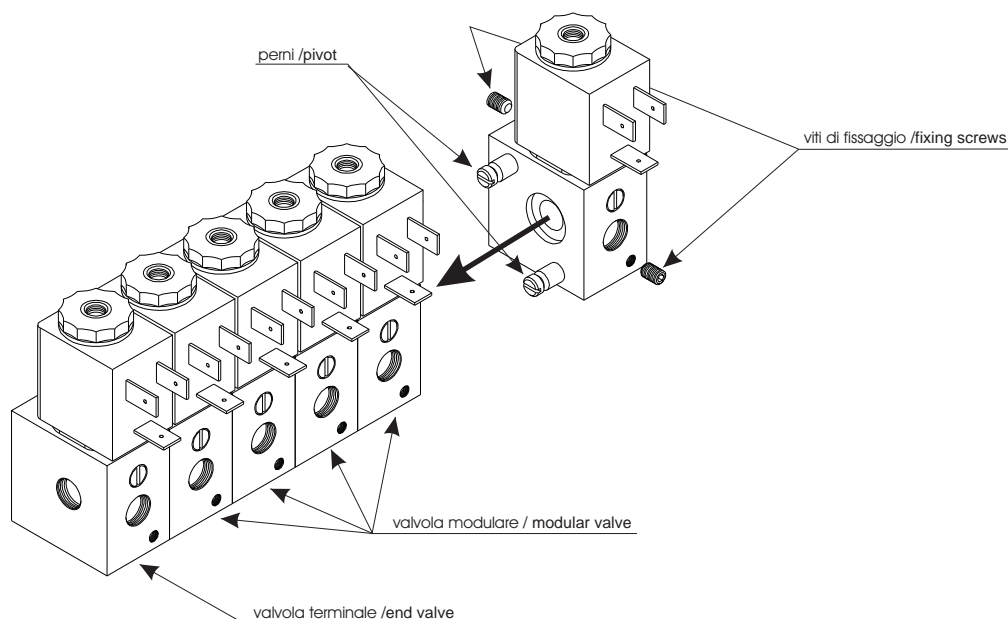

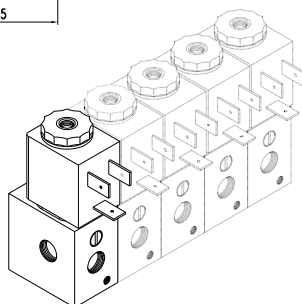
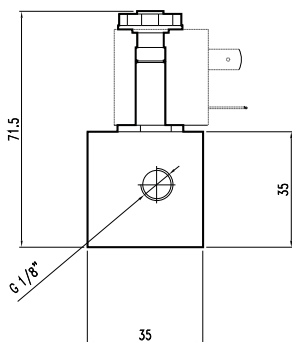
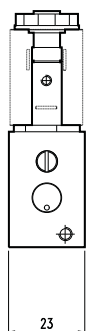
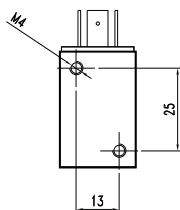

VALVOLA TERMINALE 3/2 NC
END VALVE 3/2 NC

CODE: VD32121

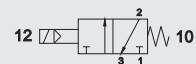

VALVOLA TERMINALE 3/2 NA
END VALVE 3/2 NO

CODE: VD32111

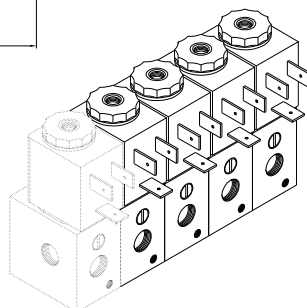
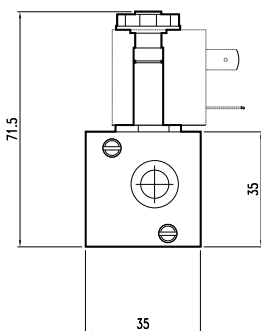
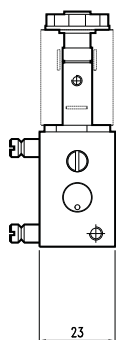
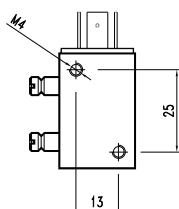
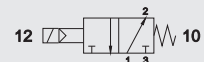

VALVOLA MODULARE 3/2 NC
MODULAR VALVE 3/2 NC

CODE: VD32122

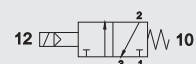

VALVOLA MODULARE 3/2 NA
MODULAR VALVE 3/2 NO

CODE: VD32112

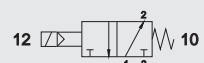

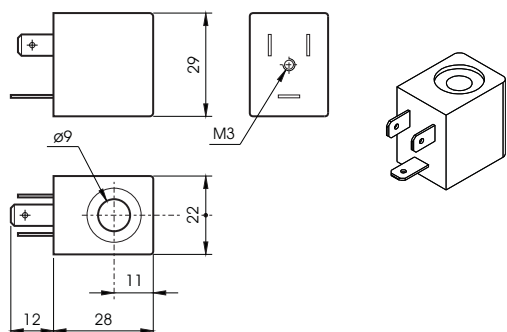

BOBINE
COIL

CODE	Tensione Tension	Assorbimento / Power a regime Rated	di spunto Inrush
BO4011024	24 VDC	3W	
BO4012024	24 VAC	5VA	7,5VA
BO4012110	110 VAC	5VA	7,5VA
BO4012220	220 VAC	5VA	7,5VA

CARATTERISTICHE TECNICHE / TECHNICAL SPECIFICATIONS

Tolleranza di tensione / Tension tolerance	+10%
Protezione con connettore / Protection with connector	IP65
Temperatura max di esercizio / Max working temperature	+50 C°
Inserimento / Duty cycle	ED 100%

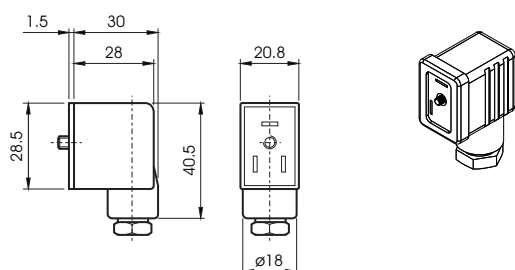

CONNETTORI
CONNECTORS

CODE	
AR40696	STANDARD
VX0014	LED 24V
VX0015	LED 110V
VX0016	LED 220V
VX0017	LED+VDR di protezione 24V
VX0018	LED+VDR di protezione 110V
VX0019	LED+VDR di protezione 220V

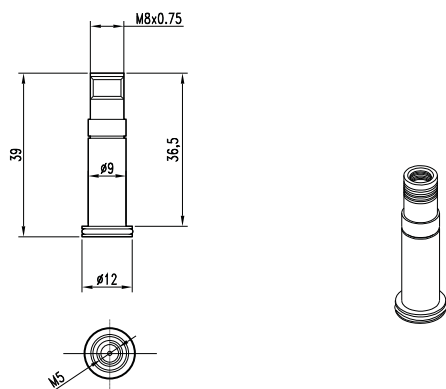

CANOTTO
SOLENOID PILOT

CODE	
EP43603	STANDARD

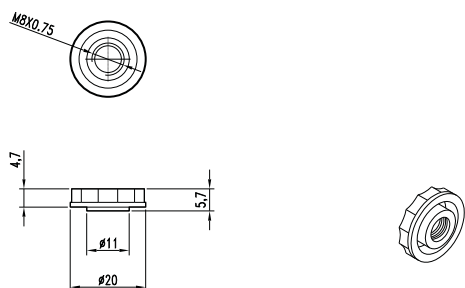

DADO
NUT

CODE	
DA42937	STANDARD

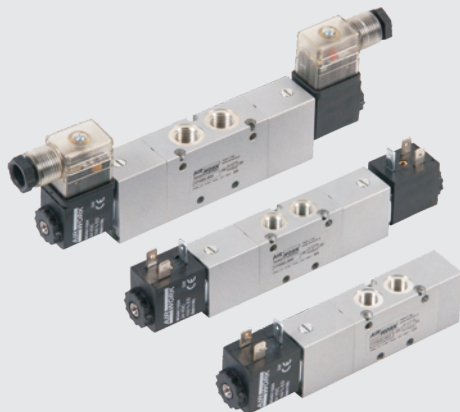

La serie di elettrovalvole di Airwork, possiedono caratteristiche di grande robustezza, affidabilità e versatilità di montaggio, infatti la serie VY si possono montare in diversi modi: in linea, a parete, su base multipla, su collettori e persino su cilindro. Sono disponibili in tre taglie 1/8, 1/4 e 1/2 nelle funzioni 3/2, 5/2 e 5/3.

Airwork's solenoid valves combine big resistance, reliability and versatility of assemblage; the VY series can be assembled in several ways: In-line, on panel, on multiple bases, on manifolds and on cylinders. Available size are 1/8, 1/4 and 1/2, the available functions are 3/2, 5/2 e 5/3.

DATI TECNICI / TECHNICAL DATA

Portata a 6 bar / Flow rate 6 bar	1/8=550 NI/min - 1/4=1100 NI/min - 1/2=4600NI/min
Diametro nominale / Nominal orifice	1/8=5mm - 1/4=7.5mm - 1/2=13mm
Tempi risposta monostabile / response times mono-stable	(1/8=TRA 15ms / TRR 35ms) (1/4=TRA 19ms / TRR 45ms) (1/2=TRA 39ms / TRR 60ms)
Tempi risposta bistabile / response times bi-stable	(1/8=TRA 20ms / TRR 20ms) (1/4=TRA 22ms / TRR 22ms)
Tensione bobine / Coils tension	24VDC - 24VAC - 110VAC - 220VAC 50/60Hz
Pressione di esercizio / Pressure range	
* Monostabile / monostable	2.5 ÷ 10bar
* Bistabile / bistable	1 ÷ 10bar
* Alimentaz.separata / separated air supply	max 10bar
Temperatura di esercizio / Temperature range	-10 C° ÷ +60c°
Tolleranza tensione / Voltage tolerance	±10%
Assorbimento / Power consumption	2W (DC) - 3VA (AC)
Isolamento / Isulation	classe F

SELEZIONE RAPIDA / FAST SELECT

	ELETTRICO, RITORNO A MOLLA / SOLENOID, SPRING RETURN VY83ELMNC 3/2 1/8 NC VY43ELMNC 3/2 1/4 NC VY23ELMNC 3/2 1/2 NC		ALIMENTAZIONE SEPARATA / SEPARATE AIR SUPPLY VY85EAB00 5/2 1/8 VY45EAB00 5/2 1/4 VY25EAB00 5/2 1/2
	ELETTRICO, RITORNO A MOLLA / SOLENOID, SPRING RETURN VY83ELMNA 3/2 1/8 NA/NO VY43ELMNA 3/2 1/4 NA/NO VY23ELMNA 3/2 1/2 NA/NO		DOPPIO COMANDO ELETTRICO / DOUBLE SOLENOID VY86ELMCC 5/3 1/8 CC VY46ELMCC 5/3 1/4 CC VY26ELMCC 5/3 1/2 CC
	ALIMENTAZ. SEPARATA, R.M. / SEPARATE AIR SUPPLY, S.R. VY83EAMNC 3/2 1/8 NC VY43EAMNC 3/2 1/4 NC VY23EAMNC 3/2 1/2 NC		DOPPIO COMANDO ELETTRICO / DOUBLE SOLENOID VY86ELMCA 5/3 1/8 CA VY46ELMCA 5/3 1/4 CA VY26ELMCA 5/3 1/2 CA
	DOPPIO COMANDO ELETTRICO / DOUBLE SOLENOID VY83ELB00 3/2 1/8 NC VY43ELB00 3/2 1/4 NC VY23ELB00 3/2 1/2 NC		DOPPIO COMANDO ELETTRICO / DOUBLE SOLENOID VY86ELMCP 5/3 1/8 CP VY46ELMCP 5/3 1/4 CP VY26ELMCP 5/3 1/2 CP
	ALIMENTAZIONE SEPARATA / SEPARATE AIR SUPPLY VY83EAB00 3/2 1/8 NC VY43EAB00 3/2 1/4 NC VY23EAB00 3/2 1/2 NC		ALIMENTAZIONE SEPARATA / SEPARATE AIR SUPPLY VY86EAMCC 5/3 1/8 CC VY46EAMCC 5/3 1/4 CC VY26EAMCC 5/3 1/2 CC
	ELETTRICO, RITORNO A MOLLA / SOLENOID, SPRING RETURN VY85ELM00 5/2 1/8 VY45ELM00 5/2 1/4 VY25ELM00 5/2 1/2		ALIMENTAZIONE SEPARATA / SEPARATE AIR SUPPLY VY86EAMCA 5/3 1/8 CA VY46EAMCA 5/3 1/4 CA VY26EAMCA 5/3 1/2 CA
	ALIMENTAZIONE SEPARATA / SEPARATE AIR SUPPLY VY85EAM00 5/2 1/8 VY45EAM00 5/2 1/4 VY25EAM00 5/2 1/2		ALIMENTAZIONE SEPARATA / SEPARATE AIR SUPPLY VY86EAMCP 5/3 1/8 CP VY46EAMCP 5/3 1/4 CP VY26EAMCP 5/3 1/2 CP
	DOPPIO COMANDO ELETTRICO / DOUBLE SOLENOID VY85ELB00 5/2 1/8 VY45ELB00 5/2 1/4 VY25ELB00 5/2 1/2		

PORTATE / FLOW RATES

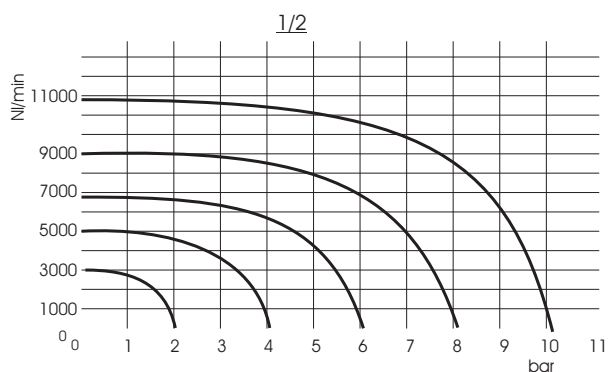
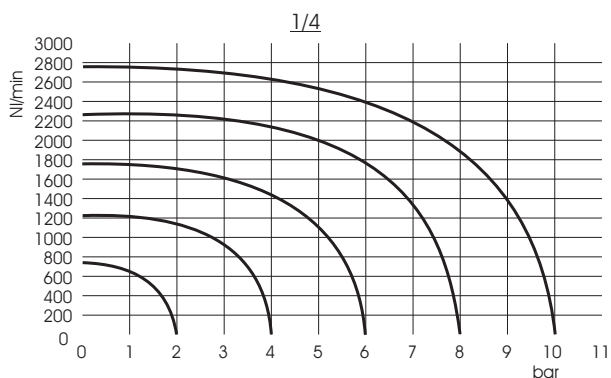
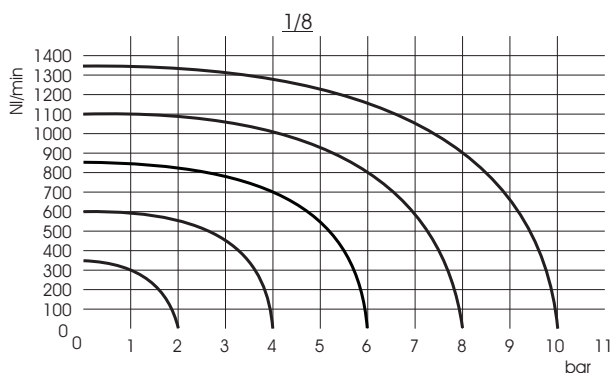

COMPONENTI / COMPONENTS

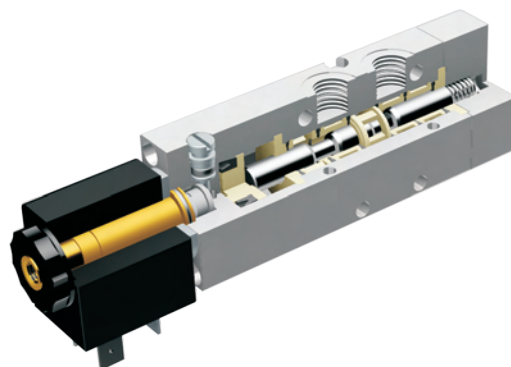
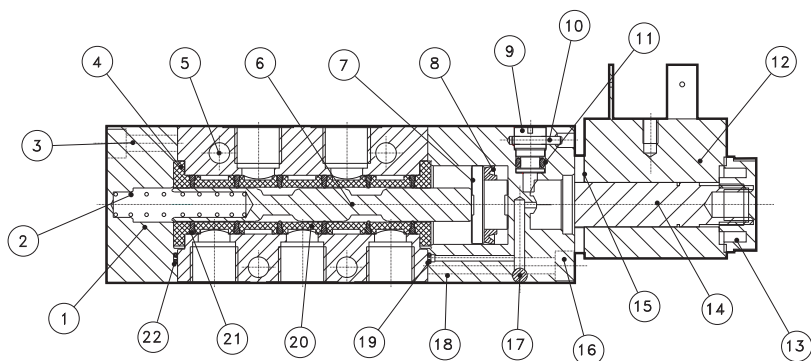

pos.	descrizione / description	materiale / material
1	fondello molla / spring bottom	alluminio / aluminium
2	molla / spring	acciaio C98 / C98 steel
3	vite / screw	acciaio / steel
4	distanziale spola / spool distance	POM hostaform C9021
5	corpo valvola / body valve	alluminio / aluminium
6	spola / spool	acciaio inox Aisi 303 / stainless steel Aisi 303
7	pistone / piston	Delring 500
8	guarnizione pistone / piston seal	NBR
9	intervento manuale / manual operating	ottone / brass
10	spina / plug	acciaio / steel
11	o-ring	NBR
12	bobina / coil	
13	dado M8x0,75 / nut M8x0,75	plastica / plastic
14	tubetto / tube	ottone / brass
15	piastrina tubetto / tube plaque	acciaio / steel
16	vite / screw	acciaio / steel
17	sfera / sphere	acciaio / steel
18	fondello elettrico / electric bottom	alluminio / aluminium
19	o-ring	NBR
20	distanziale gabbia / cage distance	POM hostaform C9021
21	guarnizioni spola / spool seal	NBR
22	o-ring	NBR

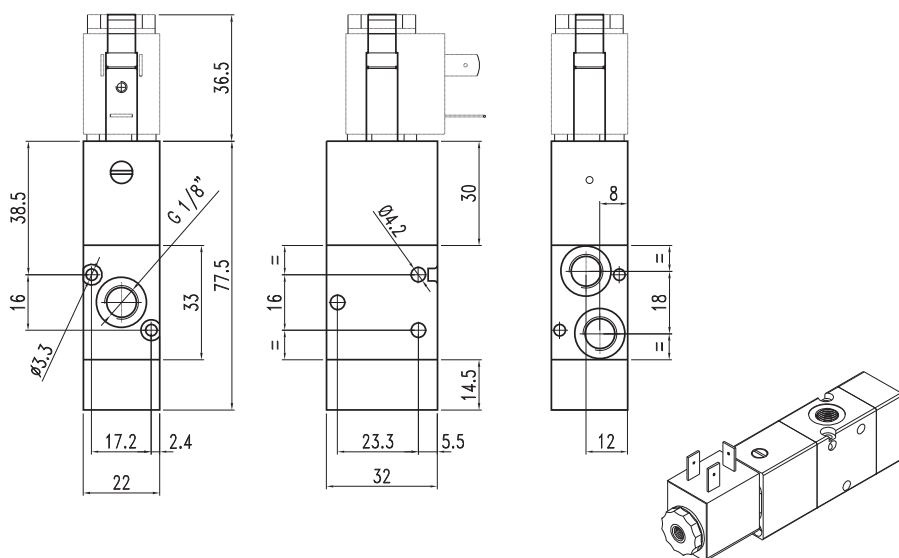

1/8 - 3/2 NC - RITORNO A MOLLA
1/8 - 3/2 NC - SPRING RETURN

CODE: VY83ELMNC

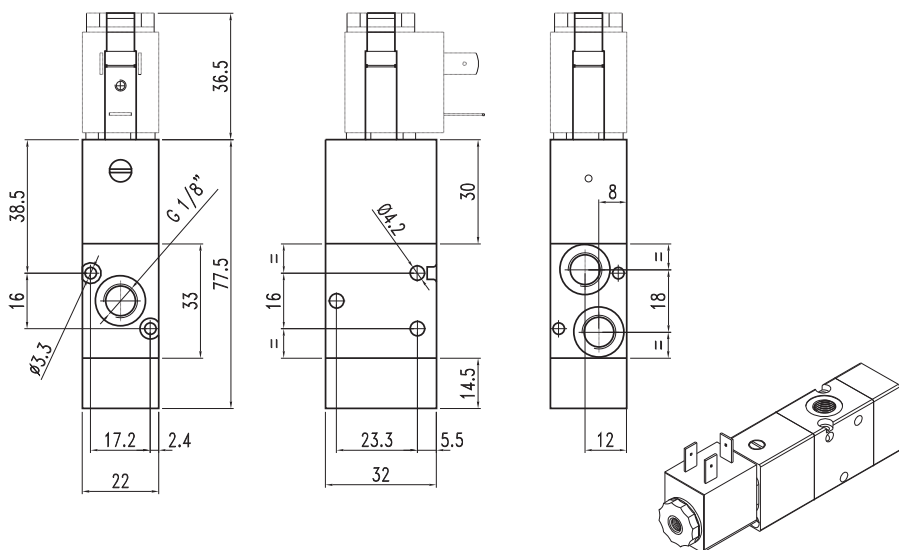
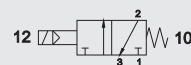

1/8 - 3/2 NA - RITORNO A MOLLA
1/8 - 3/2 NO - SPRING RETURN

CODE: VY83ELMNA

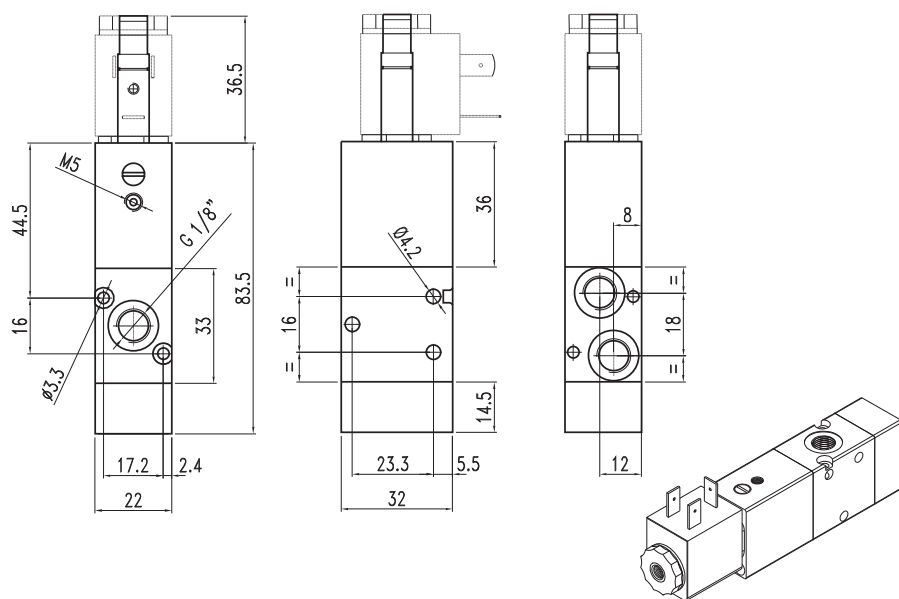
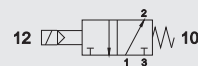

1/8 - 3/2 NC - ALIMENT. SEPARATA,
RITORNO A MOLLA
1/8 - 3/2 NC - SEPARATE AIR SUPPLY,
SPRING RETURN

CODE: VY83EAMNC

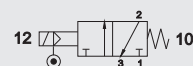

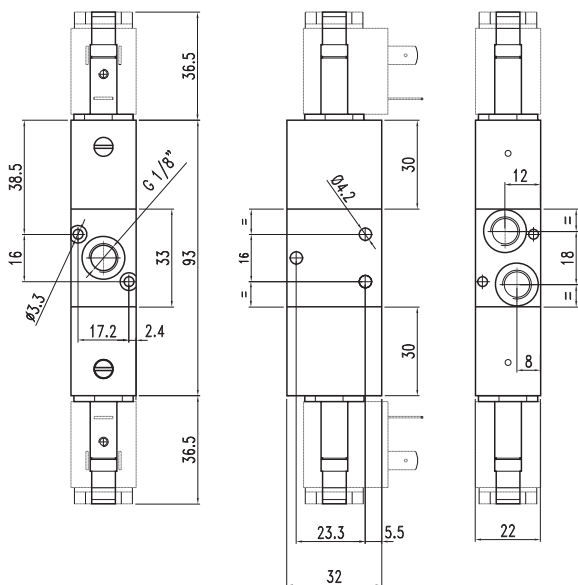

1/8 - 3/2 DOPPIO COMANDO ELETTRICO
1/8 - 3/2 DOUBLE SOLENOID

CODE: VY83ELB00

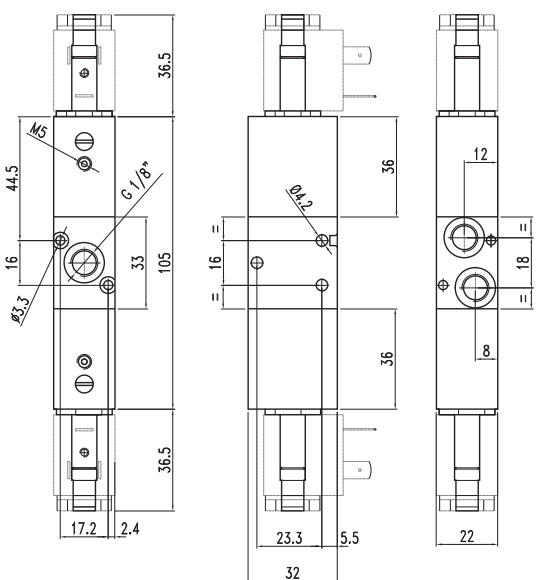
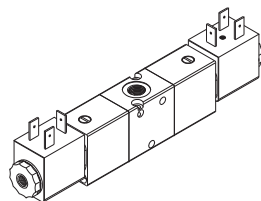
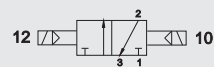

1/8 - 3/2 DOPPIO COMANDO ELETTRICO,
ALIMENTAZIONE SEPARATA
1/8 - 3/2 DOUBLE SOLENOID, SEPARATE AIR
SUPPLY

CODE: VY83EAB00

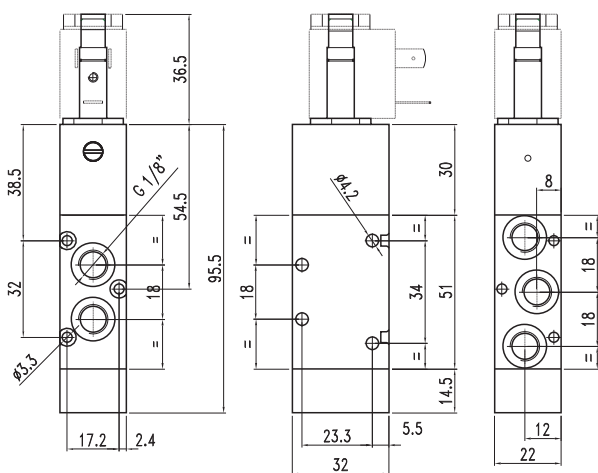
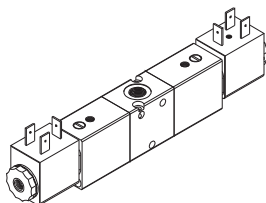
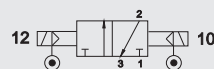

1/8 - 5/2 RITORNO A MOLLA
1/8 - 5/2 SPRING RETURN

CODE: VY85ELM00

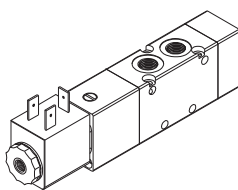
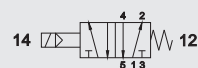

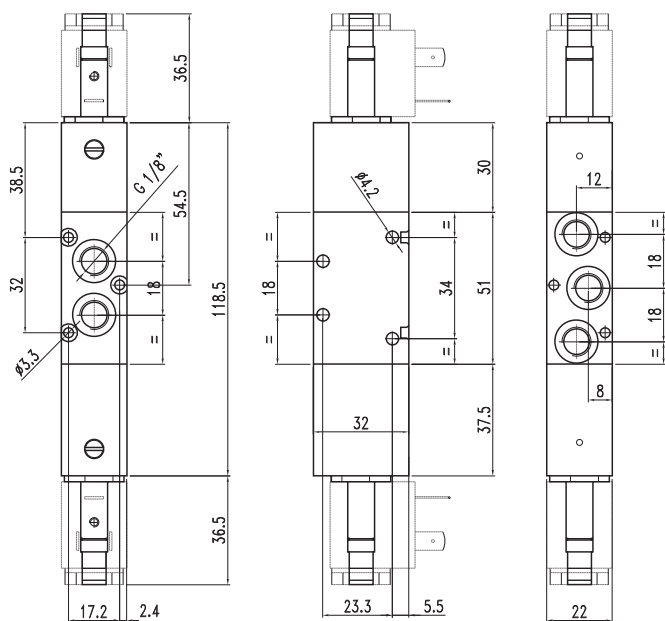

1/8 - 5/3 DOPPIO COMANDO ELETTRICO
1/8 - 5/3 DOUBLE SOLENOID

CODE: VY86ELMCC CENTRI CHIUSI
CLOSED CENTRES

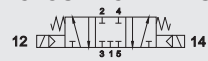

CODE: VY86ELMCA CENTRI APERTI
OPEN CENTRES



CODE: VY86ELMCP CENTRI IN PRESSIONE
PRESS. CENTRES

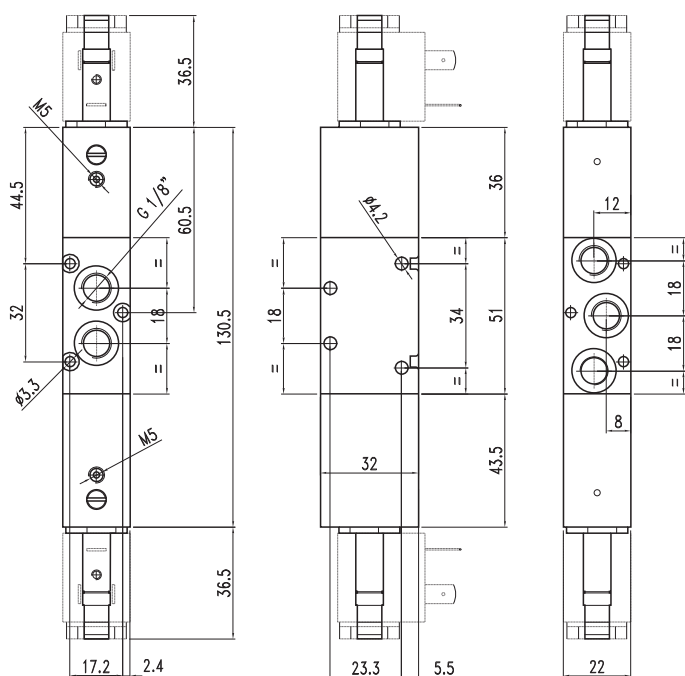
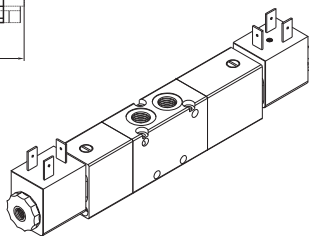
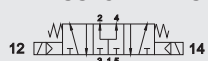

1/8 - 5/3 DOPPIO COMANDO ELETTRICO,
ALIMENTAZIONE SEPARATA
1/8 - 5/3 DOUBLE SOLENOID, SEPARATE
AIR SUPPLY

CODE: VY86EAMCC CENTRI CHIUSI
CLOSED CENTRES

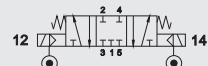

CODE: VY86EAMCA CENTRI APERTI
OPEN CENTRES

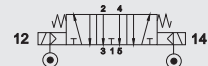

CODE: VY86EAMCP CENTRI IN PRESSIONE
PRESS. CENTRES

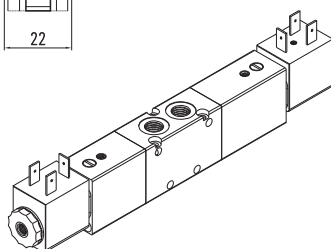
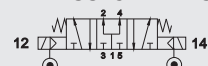

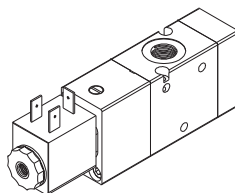
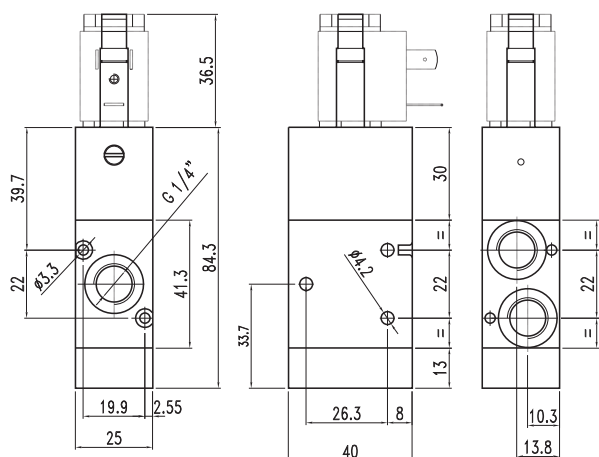

1/4 - 3/2 NC - RITORNO A MOLLA
1/4 - 3/2 NC - SPRING RETURN

CODE: VY43ELMNC

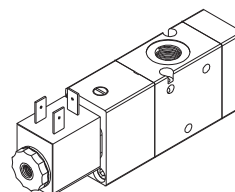
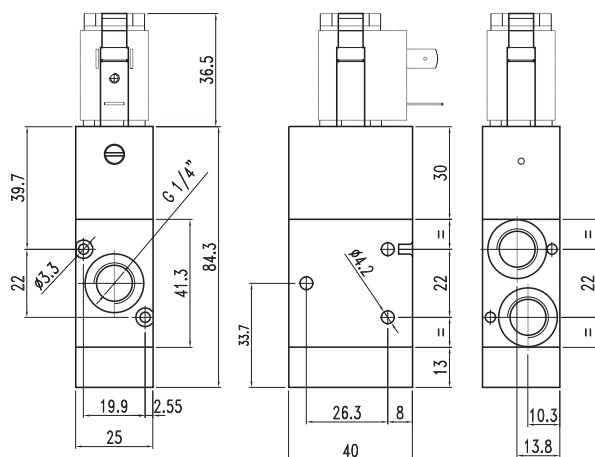
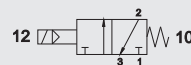

1/4 - 3/2 NA - RITORNO A MOLLA
1/4 - 3/2 NO - SPRING RETURN

CODE: VY43ELMNA

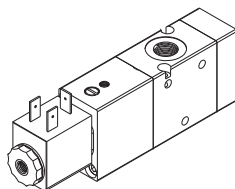
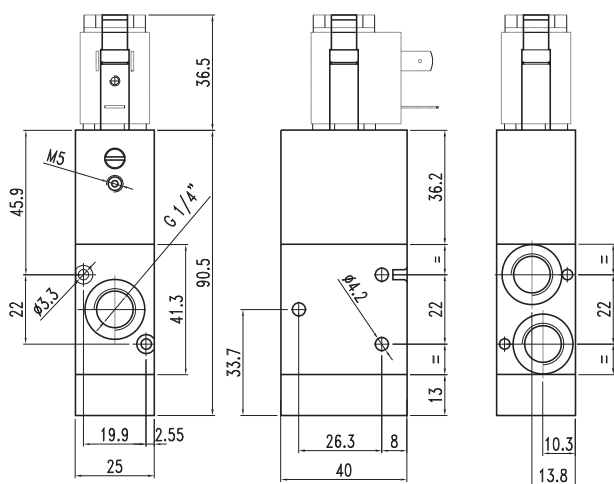
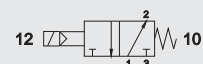

1/4 - 3/2 NC - ALIMENT.SEPARATA,
RITORNO A MOLLA
1/4 - 3/2 NC - SEPARATE AIR SUPPLY,
SPRING RETURN

CODE: VY43EAMNC

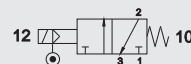

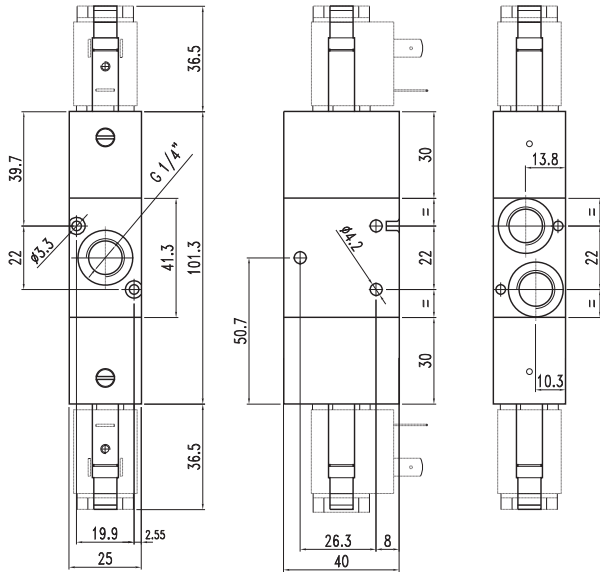

1/4 - 3/2 DOPPIO COMANDO ELETTRICO
1/4 - 3/2 DOUBLE SOLENOID

CODE: VY43ELB00

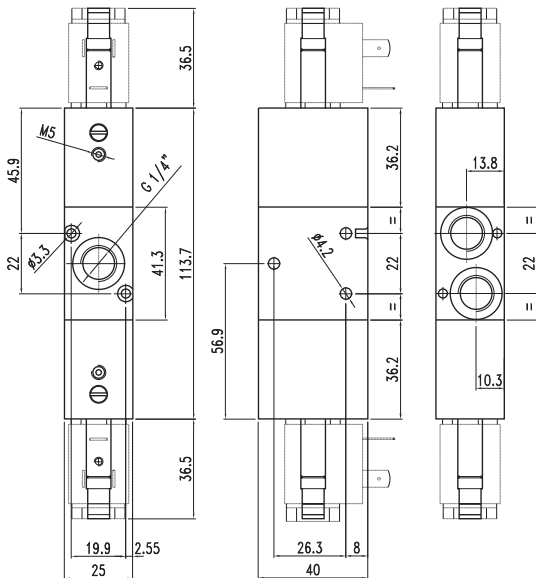
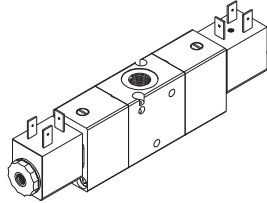
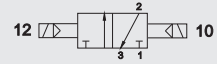

1/4 - 3/2 DOPPIO COMANDO ELETTRICO,
ALIMENTAZIONE SEPARATA
1/4 - 3/2 DOUBLE SOLENOID, SEPARATE AIR
SUPPLY

CODE: VY43EAB00

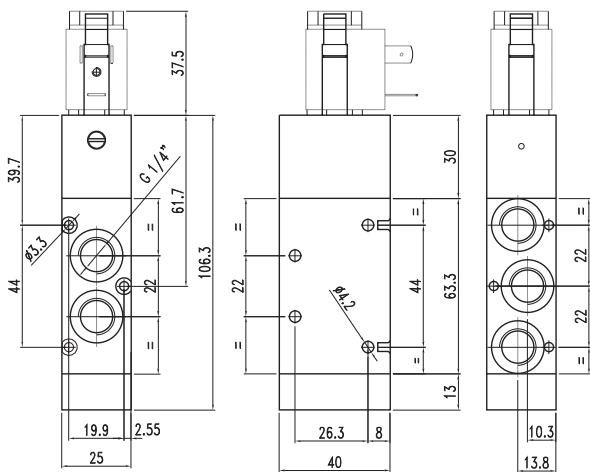
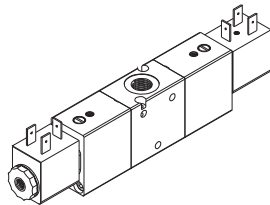
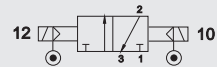

1/4 - 5/2 RITORNO A MOLLA
1/4 - 5/2 SPRING RETURN

CODE: VY45ELM00

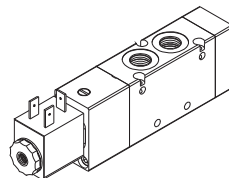
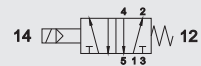

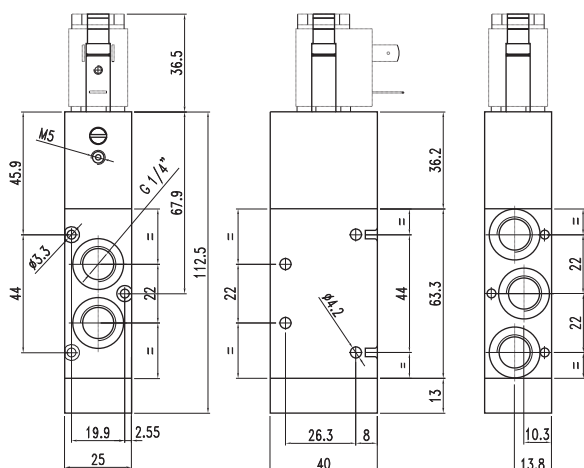

1/4 - 5/2 ALIMENTAZIONE SEPARATA, RITORNO A MOLLA
1/4 - 5/2 SEPARATE AIR SUPPLY, SPRING RETURN

CODE: VY45EAM00

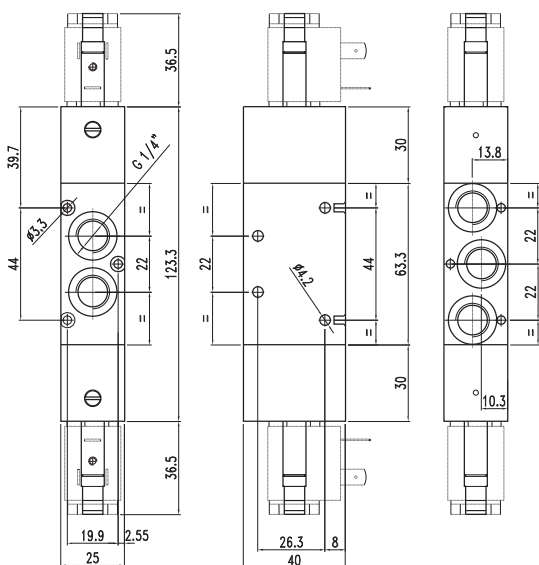
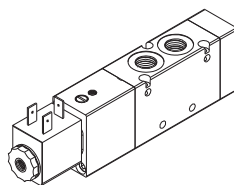

1/4 - 5/2 DOPPIO COMANDO ELETTRICO
1/4 - 5/2 DOUBLE SOLENOID

CODE: VY45ELB00

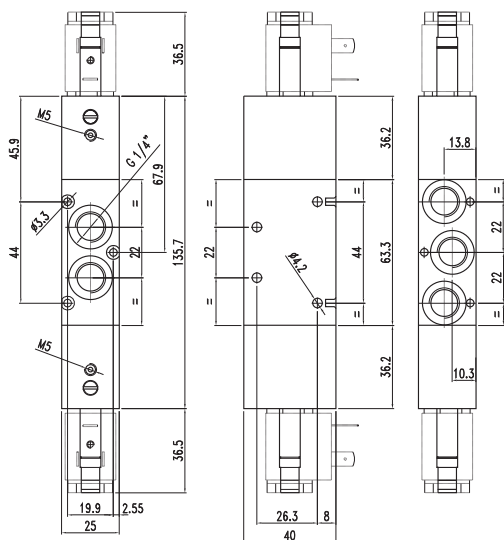
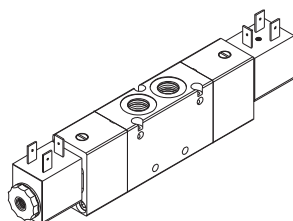
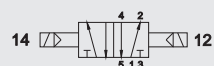

1/4 - 5/2 DOPPIO COMANDO ELETTRICO,
ALIMENTAZIONE SEPARATA
1/4 - 5/2 DOUBLE SOLENOID, SEPARATE AIR
SUPPLY

CODE: VY45EAB00

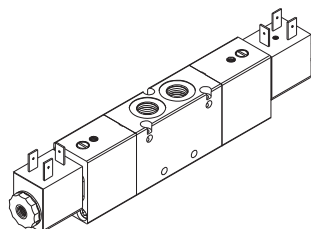
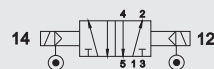

1/4 - 5/3 DOPPIO COMANDO ELETTRICO
1/4 - 5/3 DOUBLE SOLENOID

CODE: VY46ELMCC CENTRI CHIUSI
CLOSED CENTRES

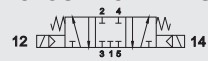

CODE: VY46ELMCA CENTRI APERTI
OPEN CENTRES



CODE: VY46ELMCP CENTRI IN PRESSIONE
PRESS. CENTRES

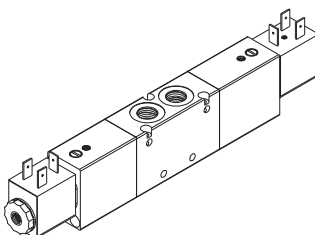
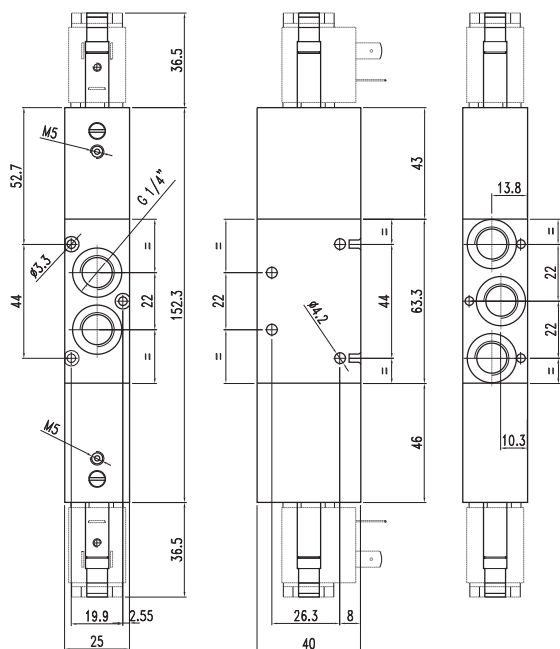
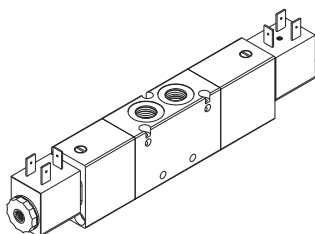
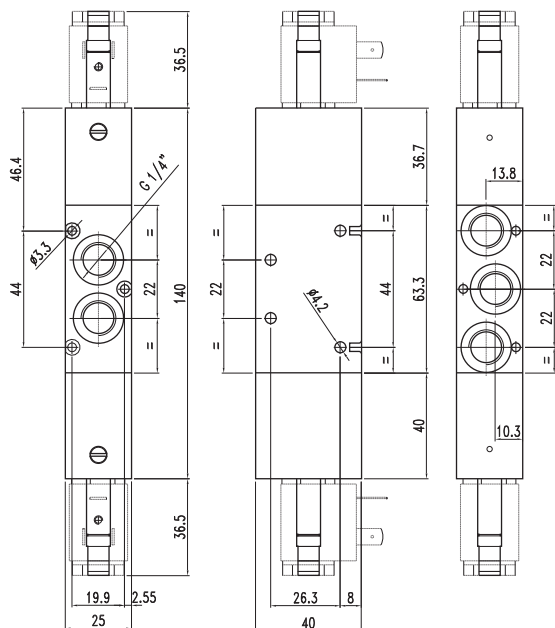
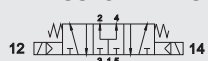

1/4 - 5/3 DOPPIO COMANDO ELETTRICO,
ALIMENTAZIONE SEPARATA
1/4 - 5/3 DOUBLE SOLENOID, SEPARATE
AIR SUPPLY

CODE: VY46EAMCC CENTRI CHIUSI
CLOSED CENTRES



CODE: VY46EAMCA CENTRI APERTI
OPEN CENTRES



CODE: VY46EAMCP CENTRI IN PRESSIONE
PRESS. CENTRES



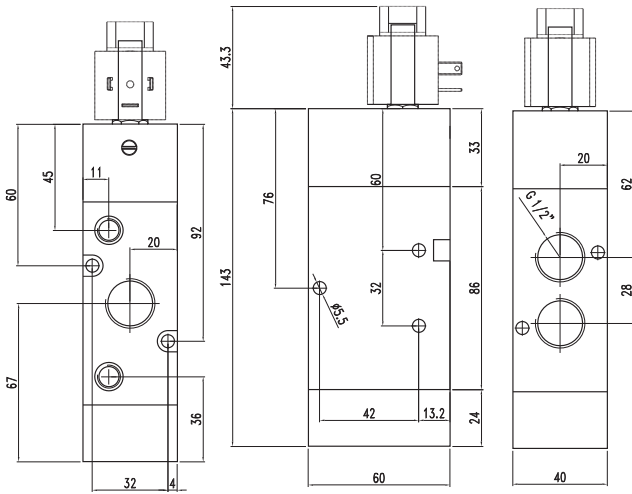

1/2 - 3/2 NC - RITORNO A MOLLA
1/2 - 3/2 NC - SPRING RETURN

CODE: VY23ELMNC

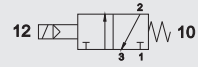

1/2 - 3/2 NA - RITORNO A MOLLA
1/2 - 3/2 NO - SPRING RETURN

CODE: VY23ELMNA

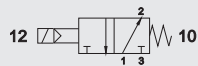

1/2 - 3/2 NC - ALIMENT. SEPARATA,
RITORNO A MOLLA
1/2 - 3/2 NC - SEPARATE AIR SUPPLY,
SPRING RETURN

CODE: VY23EAMNC

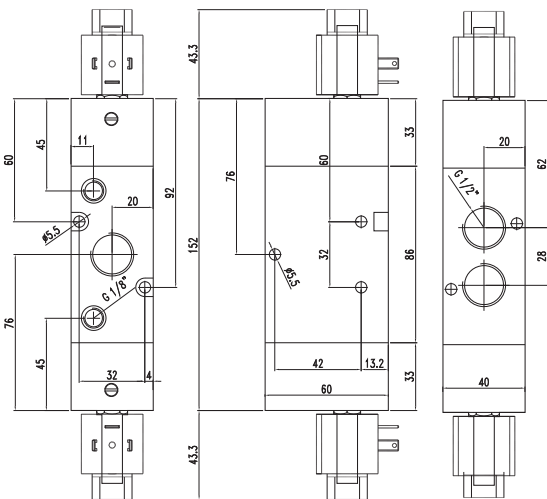
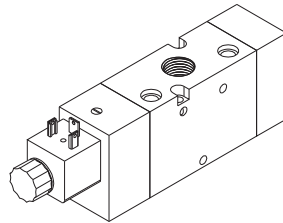
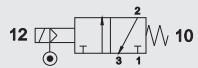

1/2 - 3/2 DOPPIO COMANDO ELETTRICO
1/2 - 3/2 DOUBLE SOLENOID

CODE: VY23ELB00

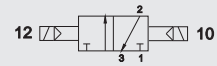

1/2 - 3/2 DOPPIO COMANDO ELETTRICO,
ALIMENTAZIONE SEPARATA
1/2 - 3/2 DOUBLE SOLENOID, SEPARATE AIR
SUPPLY

CODE: VY23EAB00

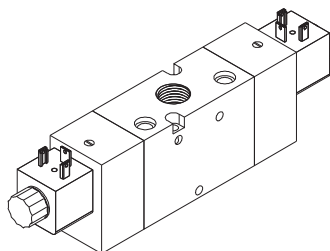
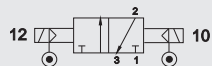

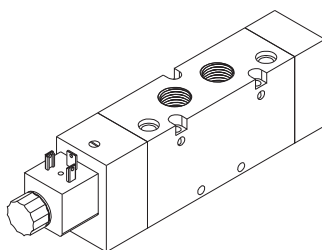
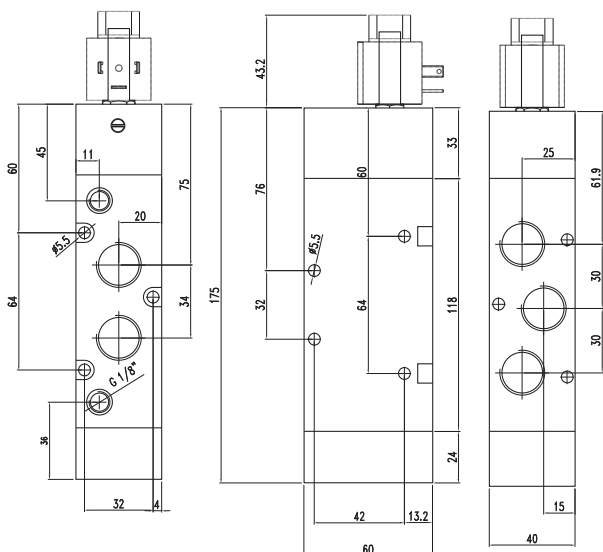

1/2 - 5/2 RITORNO A MOLLA
1/2 - 5/2 SPRING RETURN

CODE: VY25ELM00

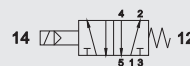

1/2 - 5/2 ALIMENTAZIONE SEPARATA, RITORNO A MOLLA
1/2 - 5/2 SEPARATE AIR SUPPLY, SPRING RETURN

CODE: VY25EAM00

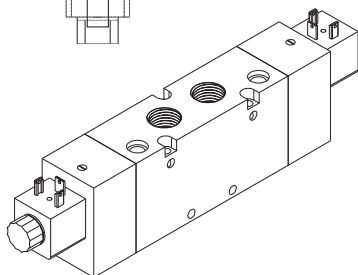
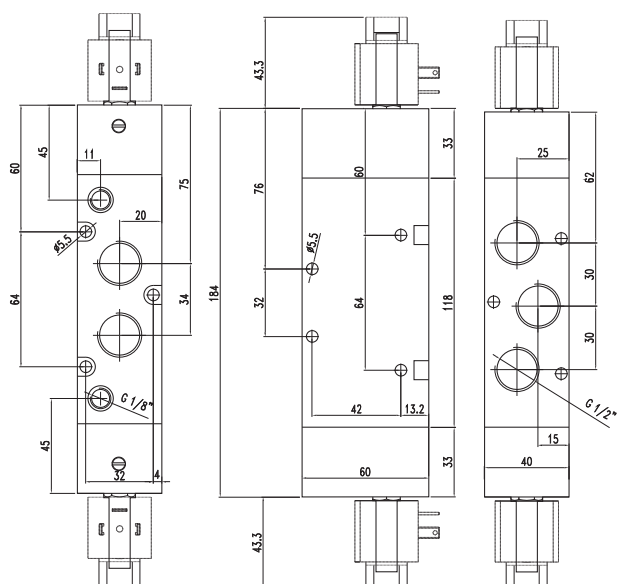
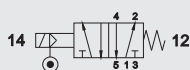

1/2 - 5/2 DOPPIO COMANDO ELETTRICO
1/2 - 5/2 DOUBLE SOLENOID

CODE: VY25ELB00

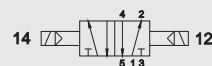

1/2 - 5/2 DOPPIO COMANDO ELETTRICO,
ALIMENTAZIONE SEPARATA
1/2 - 5/2 DOUBLE SOLENOID, SEPARATE AIR SUPPLY

CODE: VY25EAB00

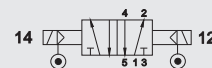

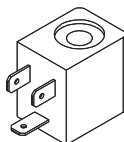
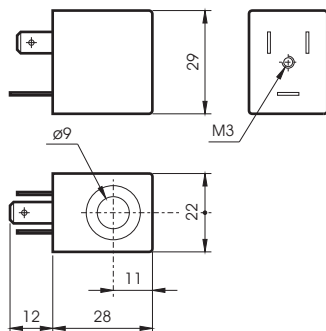

BOBINE
COILS

CODE	Tensione Tension	Assorbimento a regime Power Rated	di spunto Inrush
BO4011024	24 VDC	3W	
BO4012024	24 VAC	5VA	7,5VA
BO4012110	110 VAC	5VA	7,5VA
BO4012220	220 VAC	5VA	7,5VA

CARATTERISTICHE TECNICHE / TECHNICAL SPECIFICATIONS

Tolleranza di tensione / Tension tolerance	+10%
Protezione con connettore / Protection with connector	IP65
Temperatura max di esercizio / Max working temperature	+50 C°
Inserimento / Duty cycle	ED 100%

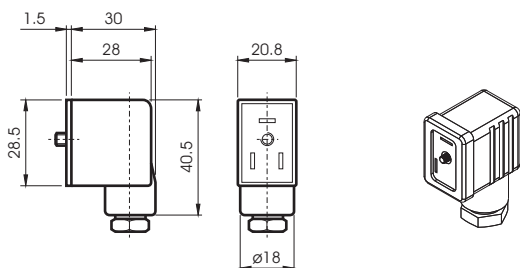

CONNETTORI
CONNECTORS

CODE	
AR40696	STANDARD
VX0014	LED 24V
VX0015	LED 110V
VX0016	LED 220V
VX0017	LED+VDR di protezione 24V
VX0018	LED+VDR di protezione 110V
VX0019	LED+VDR di protezione 220V

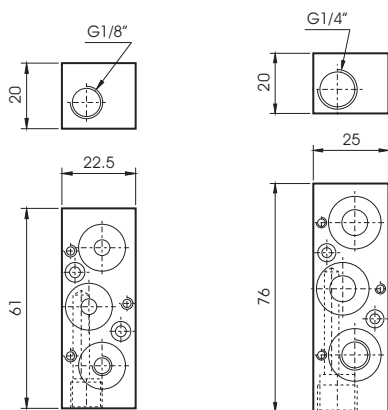

ADATTATORE PER ENTRATA SEPARATA
ADAPTOR PLATE FOR SEPARATE AIR LINE

CODE	
SB40720011	1/8
SB40730011	1/4

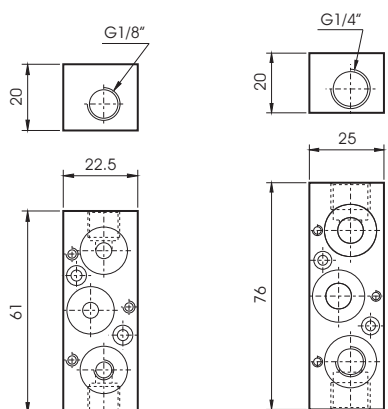

ADATTATORE PER SCARICHI SEPARATI
ADAPTOR PLATE FOR SEPARATE AIR EXHAUST

CODE	
SB40720012	1/8
SB40730012	1/4

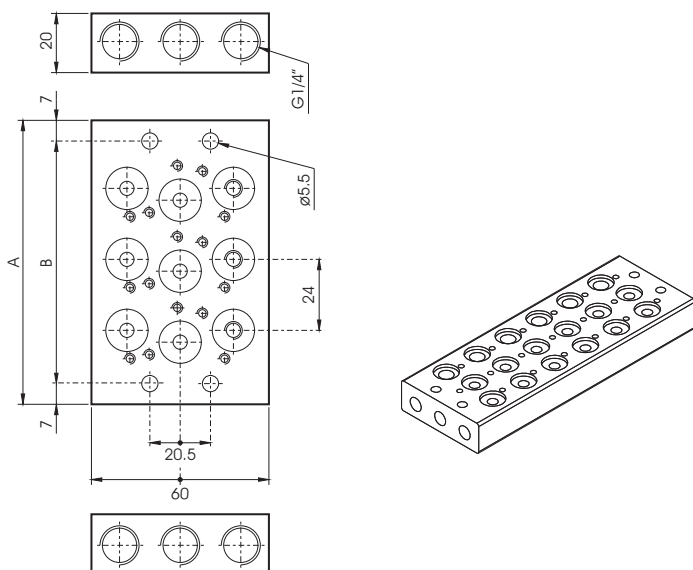

SOTTOBASE PER VALVOLE 1/8
MANIFOLD FOR 1/8 VALVES

CODE	STATIONS	A	B
SB407202	2	72	58
SB407203	3	96	82
SB407204	4	120	106
SB407205	5	144	130
SB407206	6	168	154
SB407207	7	192	178
SB407208	8	216	202
SB407209	9	240	226
SB407210	10	264	250

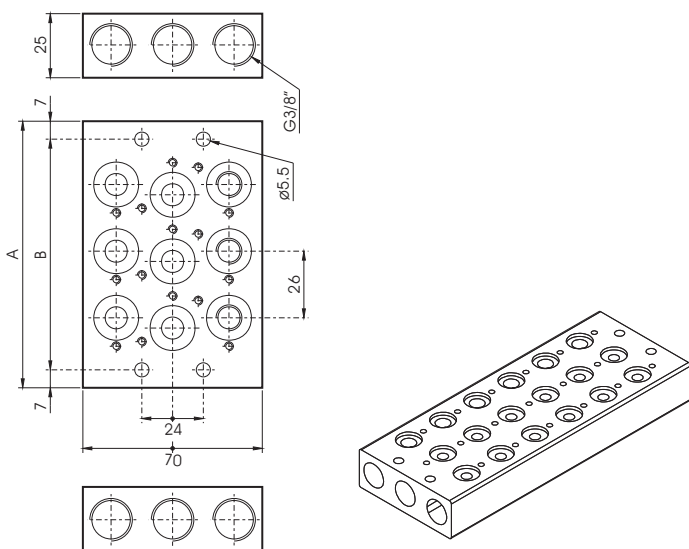

SOTTOBASE PER VALVOLE 1/4
MANIFOLD FOR 1/4 VALVES

CODE	STATIONS	A	B
SB407302	2	78	64
SB407303	3	104	90
SB407304	4	130	116
SB407305	5	156	142
SB407306	6	182	168
SB407307	7	208	194
SB407308	8	234	220

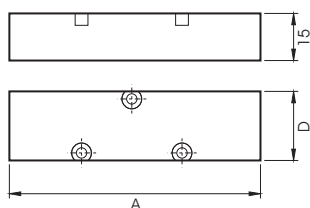

PIASTRINA DI CHIUSURA
BLANKING PLATE

CODE		A	D
SB40720004	1/8	60	22
SB40730004	1/4	70	25

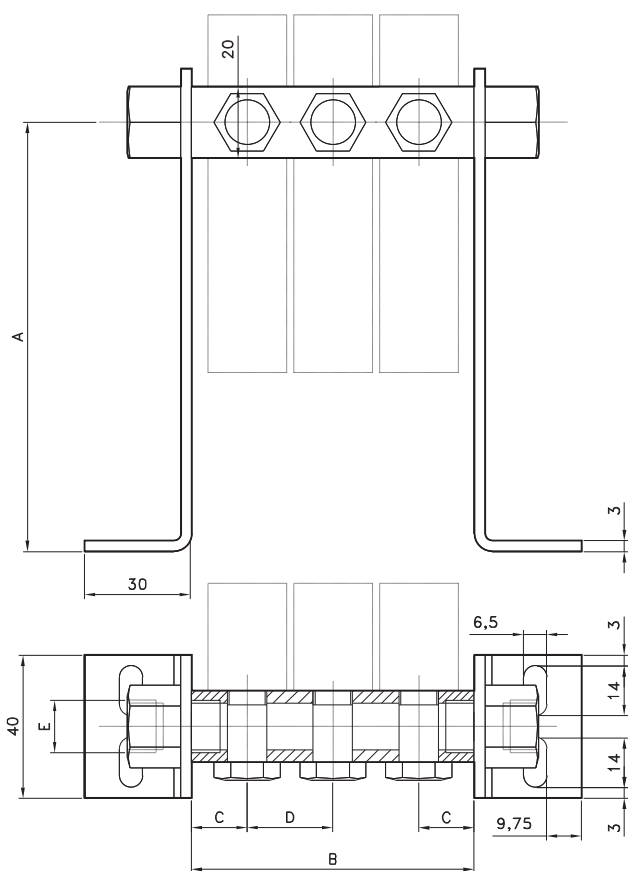
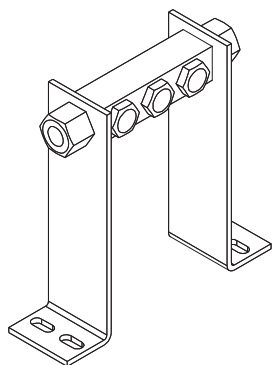

COLLETTORE 1/8
MANIFOLD 1/8

CODE	STATIONS
SB417202	2
SB417203	3
SB417204	4
SB417205	5
SB417206	6

COLLETTORE 1/4
MANIFOLD 1/4

CODE	STATIONS
SB417302	2
SB417303	3
SB417304	4
SB417305	5
SB417306	6

KIT PIEDINI 1/8
KIT PEDESTAL 1/8

CODE	A
SB4372	60
SB4472	120

KIT PIEDINI 1/4
KIT PEDESTAL 1/4

CODE	A
SB4373	60
SB4473	120

VALVOLA	A				
1/8"	120				
	60				
1/4"	120				
	60				
VALVOLA	POS.	B	C	D	E
1/8"	2	55	15.5	24	G1/4"
	3	79	15.5	24	G1/4"
	4	103	15.5	24	G1/4"
	5	127	15.5	24	G1/4"
	6	151	15.5	24	G1/4"
1/4"	2	62	17.5	27	G3/8"
	3	89	17.5	27	G3/8"
	4	116	17.5	27	G3/8"
	5	143	17.5	27	G3/8"
	6	170	17.5	27	G3/8"

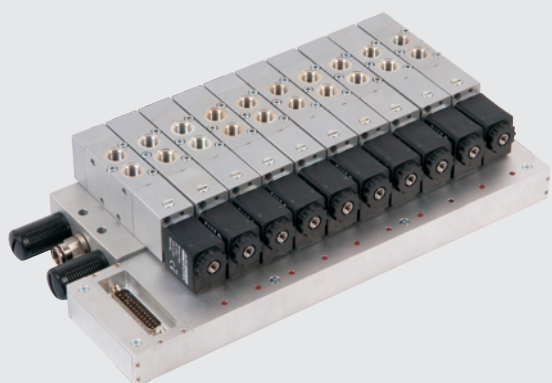

Questo sistema permette il montaggio di una serie di elettrovalvole da 1/8 di diversa funzione: 5/2 monostabile 5/2 bistabile e 5/3, grazie ad un circuito stampato inserito in un guscio di alluminio con una connessione femmina SUB-D 25 pin, evitando così il cablaggio di ogni singola valvola.

Grazie ad un sistema di codifica molto semplice ed intuitivo, è possibile ordinare l'isola con elettrovalvole montate e collaudate oppure è possibile ordinare la sola base montando le elettrovalvole in un secondo tempo.

This system allows the installation of a series of 1/8 solenoid valves with different functions: 5 / 2 monostable 5 / 2 bistable and 5 / 3, through a printed circuit board inserted in an aluminum shell with a female connection SUB-D 25 pin; this avoids the wiring of each valve.

Thanks to a simple and intuitive coding system, it is possible to order the island with mounted and tested solenoid, or also to just order the island and mount the solenoid valves at a later date.

CHIAVE DI CODIFICA / KEY TO TYPE NUMBER

SM 0,00,00000,0

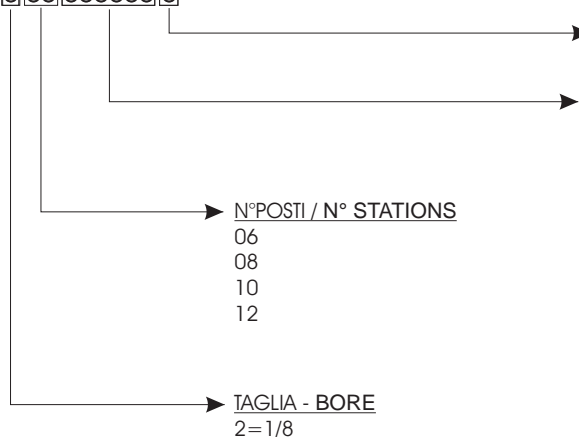

3=CONNESSIONE SUB-D 25 PIN / 25 PIN SUB-D CONNECTOR

VALVOLE / SOLENOID VALVES

- S=VY85ELM00 (5/2 singolo solenoide / single solenoid)
- D=VY85ELB00 (5/2 doppio solenoide / double solenoid)
- C=VY86ELMCC (5/3 centri chiusi / closed centers)
- O=VY86ELMCA (5/3 centri aperti / open centers)
- P=VY86ELMCP (5/3 centri in pressione / pressurized centers)
- B=PIASTRINA DI CHIUSURA / BLANKING PLATE

Per ogni valvola doppio solenoide, si deve considerare 2 postazioni (una per la valvola e l'altra per l'adattatore che è compreso).

For every requested double solenoid valve, it is necessary to consider 2 stations (one is for the valve and the other is for the included adaptor).

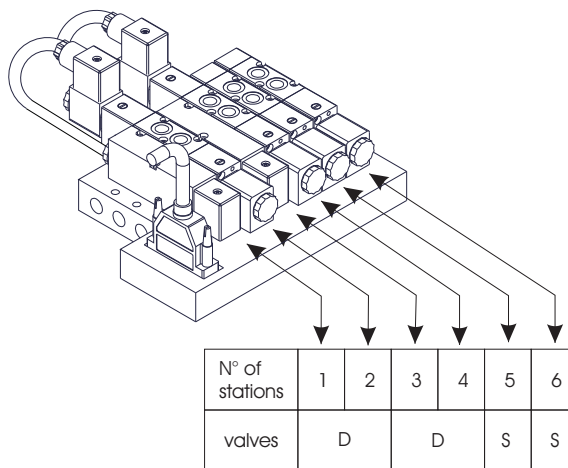

DATI TECNICI / TECHNICAL DATA

Temperatura di esercizio / Operating temperature range	-0C° / +50C°
Pressione massima di esercizio / Max operating pressure	10 bar
Portata / Flow rate	550 NI/min
Segnalazione di stato / Visualization	Led rosso / Red Led
Tensione di alimentazione / Voltage	24 V DC - 24V AC
Connessioni / Connections	1/8 Out - 1/4 In
Connessione ingresso / Electric connections	Sub-D 25 pin
Frequenza massima / Maximum frequency	5 cicli/sec.

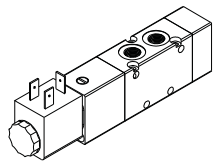

1/8 - 5/2 RITORNO A MOLLA
1/8 - 5/2 SPRING RETURN

CODE: VY85ELM00

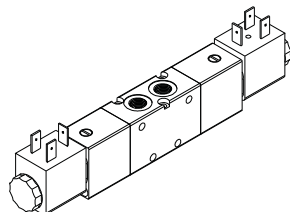
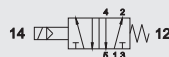

1/8 - 5/2 DOPPIO COMANDO ELETTRICO
1/8 - 5/2 DOUBLE SOLENOID

CODE: VY85ELB00

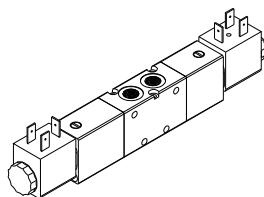

1/8 - 5/3 DOPPIO COMANDO ELETTRICO
1/8 - 5/3 DOUBLE SOLENOID

CODE: VY86ELMCC



CODE: VY86ELMCA

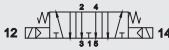

CODE: VY86ELMCP

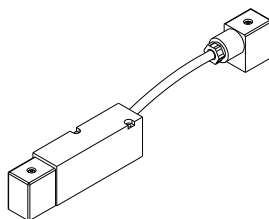

ADATTATORE PER VALVOLA DOPPIO SOLENOIDE /
ADAPTOR FOR DOUBLE SOLENOID VALVE

CODE: VX0001

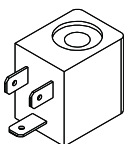

BOBINE/ COIL 24 VDC

CODE: BO4001024

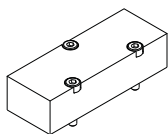

PIASTRINA DI CHIUSURA / BLANKING PLATE

CODE.: SB401212

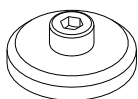

TAPPO PER CONNESSIONE ELETTRICA /
BLANKING PLATE FOR ELECTRIC CONNECTION

CODE.: VX0005

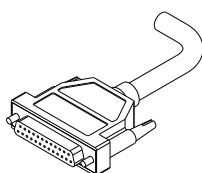

CONNETTORE SUB-D 25 PIN CON CAVO 1,5 MT
CONNECTOR SUB-D 25 PIN WITH CABLE 1,5 MT

CODE: VX0004

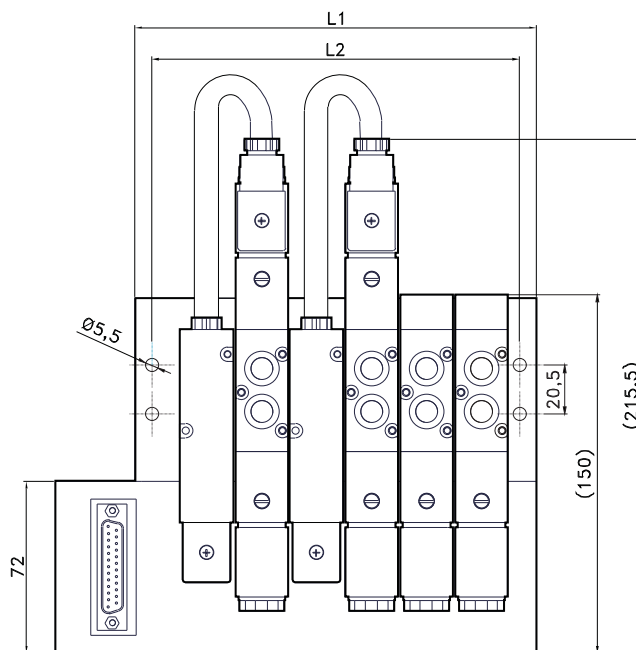
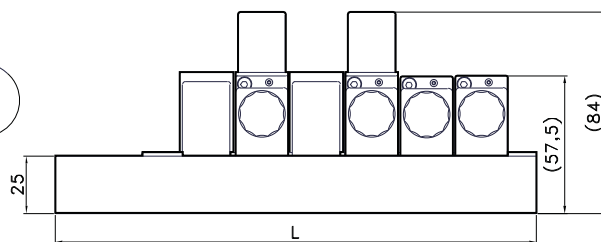
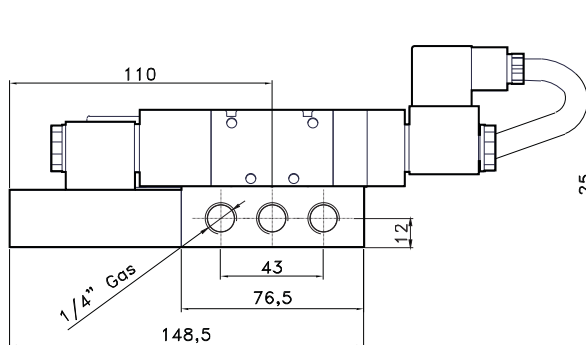

Stations	L	L1	L2
2	109,5	72	58
3	132,5	96	82
4	155,5	120	106
5	178,5	144	130
6	201,5	168	154
7	224,5	192	178
8	247,5	216	202
9	270,5	240	226
10	293,5	264	250
11	316,5	288	274
12	339,5	312	298

CONNESSIONE ELETTRICHE - ELECTRICAL CONNECTORS

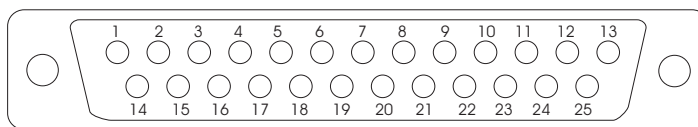

PIN	COLOR	BOBINA/COIL
1	marrone/brown	1
2	rosso/red	2
3	arancio/orange	3
4	rosa/pink	4
5	giallo/yellow	5
6	verde/green	6
7	verdino/light green	7
8	blu/blue	8
9	azzurro/light blue	9
10	viola/purple	10
11	grigio/gray	11
12	bianco/white	12
13	nero/black	negativo

PIN	COLOR	BOBINA/COIL
14	marrone chiaro/light brown	14
15	marrone nero/brown black	15
16	arancio nero/orange black	16
17	rosa nero/pink black	17
18	giallo nero/Yellow black	18
19	verde nero/green black	19
20	verdino nero/light green black	20
21	violetto/light purple	21
22	azzurro nero/light blue black	22
23	violetto nero/light purple black	23
24	grigio nero/gray black	24
25	bianco nero/white black	negativo



La serie di valvole pneumatiche di Airwork, possiedono caratteristiche di grande robustezza, affidabilità e versatilità di montaggio, infatti la serie VK si possono montare in diversi modi: in linea, a parete, su base multipla, su collettori e persino su cilindro. Sono disponibili in tre taglie 1/8, 1/4 e 1/2 nelle funzioni 3/2, 5/2 e 5/3.

Airwork's pneumatic valves combine big resistance, reliability and versatility of assemblage; the VK series can be assembled in several ways: In-line, on panel, on multiple bases, on manifolds and on cylinders. Available size are 1/8, 1/4 and 1/2, the available functions are 3/2, 5/2 e 5/3.

DATI TECNICI / TECHNICAL DATA

Portata a 6 bar / Flow rates 6 bar	1/8=550 NI/min - 1/4=1100 NI/min - 1/2=4600NI/min
Diametro nominale / Nominal orifice	1/8=5mm - 1/4=7.5mm - 1/2=13mm
Tempi risposta monostabile / response times mono-stable	(1/8=TRA 6ms / TRR 15ms) (1/4=TRA 7ms / TRR 15ms) (1/2=TRA 24ms / TRR 43ms)
Tempi risposta bistabile / response times bi-stable	(1/8=TRA 7ms / TRR 7ms) (1/4=TRA 7ms / TRR 7ms) (1/2=TRA 30ms / TRR 30ms)
Pressione di esercizio / Pressure range	
* Monostabile / monostable	2.5 ÷ 10bar
* Bistabile / bi-stable	1 ÷ 10bar
Temperatura di esercizio / Temperature range	-10 C° ÷ +60C°

PORTATE / FLOW RATES

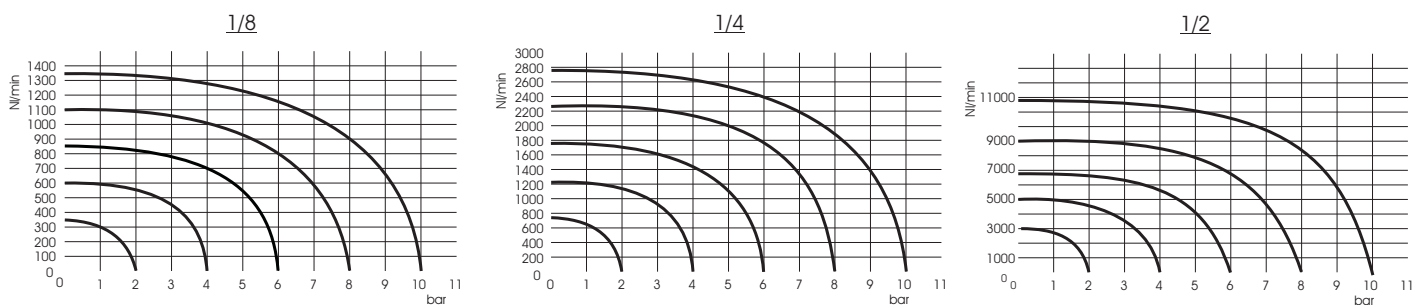

SELEZIONE RAPIDA / FAST SELECT

	PNEUMATICO - RIT. A MOLLA / PNEUMATIC - SPRING RETURN VK83PNMNC 3/2 1/8 NC VK43PNMNC 3/2 1/4 NC VK23PNMNC 3/2 1/2 NC		DOPPIO COM.PNEUMATICO / DOUBLE PNEUMATIC PILOT VK85PNB00 5/2 1/8 VK45PNB00 5/2 1/4 VK25PNB00 5/2 1/2
	PNEUMATICO - RIT. A MOLLA / PNEUMATIC - SPRING RETURN VK83PNMNA 3/2 1/8 NA/NO VK43PNMNA 3/2 1/4 NA/NO VK23PNMNA 3/2 1/2 NA/NO		DOPPIO COM.PNEUMATICO / DOUBLE PNEUMATIC PILOT VK86PNMCC 5/3 1/8 VK46PNMCC 5/3 1/4 VK26PNMCC 5/3 1/2
	DOPPIO COM.PNEUMATICO / DOUBLE PNEUMATIC PILOT VK83PNB00 3/2 1/8 VK43PNB00 3/2 1/4 VK23PNB00 3/2 1/2		DOPPIO COM.PNEUMATICO / DOUBLE PNEUMATIC PILOT VK86PNMCA 5/3 1/8 VK46PNMCA 5/3 1/4 VK26PNMCA 5/3 1/2
	PNEUMATICO - RIT. A MOLLA / PNEUMATIC - SPRING RETURN VK85PNM00 5/2 1/8 VK45PNM00 5/2 1/4 VK25PNM00 5/2 1/2		DOPPIO COM.PNEUMATICO / DOUBLE PNEUMATIC PILOT VK86PNMCP 5/3 1/8 VK46PNMCP 5/3 1/4 VK26PNMCP 5/3 1/2

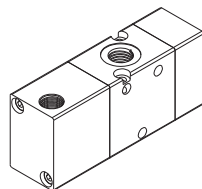
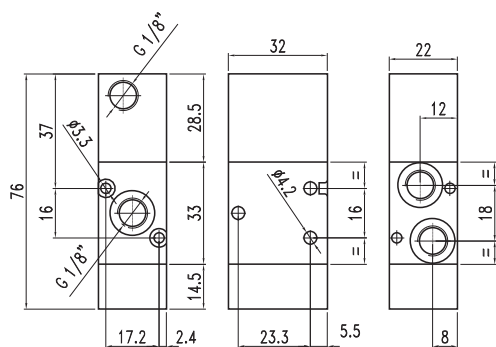

1/8 - 3/2 NC - RITORNO A MOLLA
1/8 - 3/2 NC - SPRING RETURN

CODE: VK83PNMNC

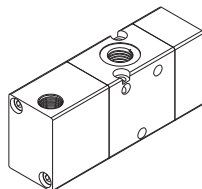
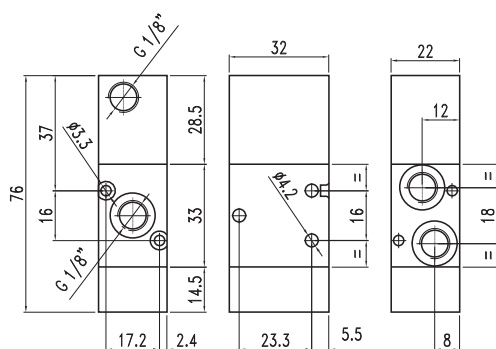
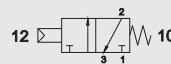

1/8 - 3/2 NA - RITORNO A MOLLA
1/8 - 3/2 NO - SPRING RETURN

CODE: VK83PNMNA

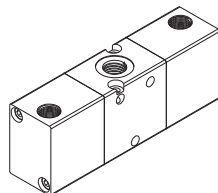
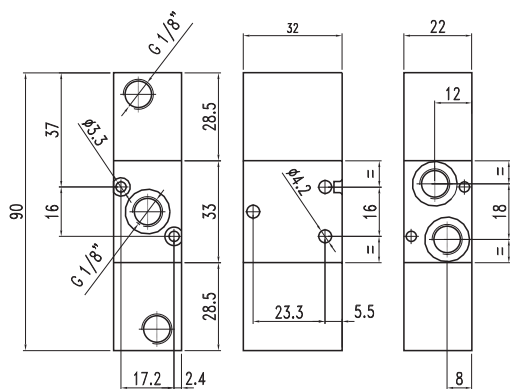
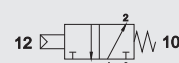

1/8 - 3/2 DOPPIO COMANDO PNEUMATICO
1/8 - 3/2 DOUBLE PNEUMATIC PILOT

CODE: VK83PNB00

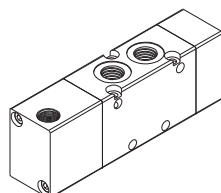
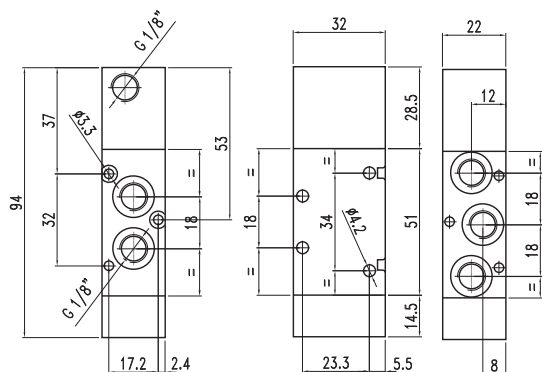
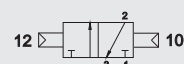

1/8 - 5/2 RITORNO A MOLLA
1/8 - 5/2 SPRING RETURN

CODE: VK85PNM00

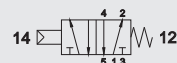

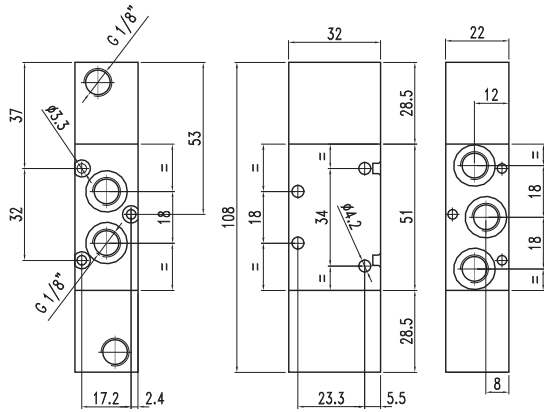

1/8 - 5/2 DOPPIO COMANDO PNEUMATICO
1/8 - 5/2 DOUBLE PNEUMATIC PILOT

CODE: VK85PNB00

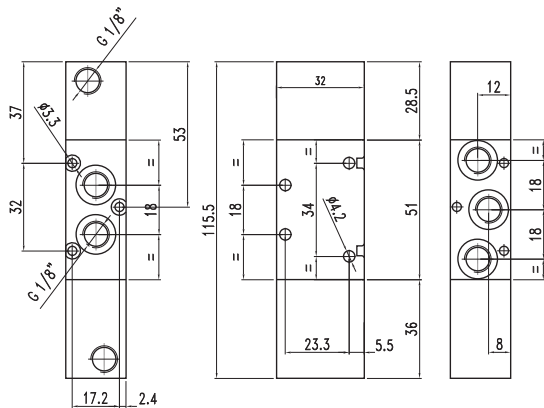
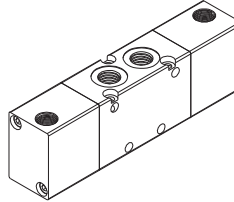
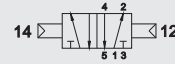

1/8 - 5/3 DOPPIO COMANDO PNEUMATICO
1/8 - 5/3 DOUBLE PNEUMATIC PILOT

CODE: VK86PNMCC CENTRI CHIUSI
CLOSED CENTRES

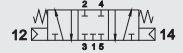

CODE: VK86PNMCA CENTRI APERTI
OPEN CENTRES

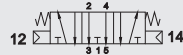

CODE: VK86PNMCP CENTRI IN PRESSIONE
PRESS. CENTRES

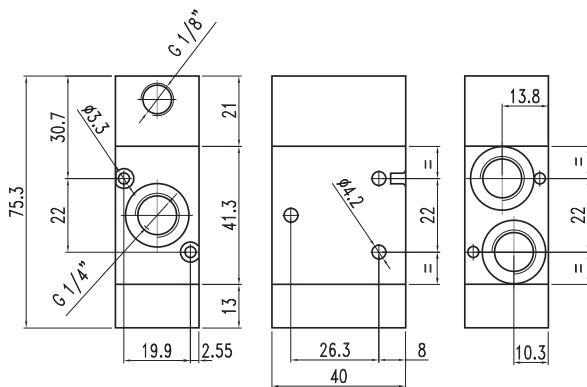
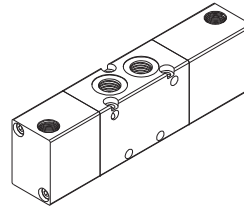
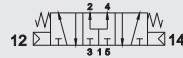

1/4 - 3/2 NC - RITORNO A MOLLA
1/4 - 3/2 NC - SPRING RETURN

CODE: VK43PNMNC

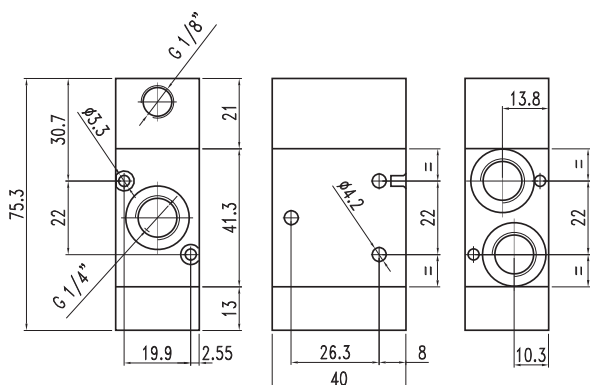
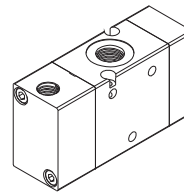
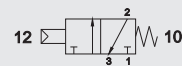

1/4 - 3/2 NA - RITORNO A MOLLA
1/4 - 3/2 NO - SPRING RETURN

CODE: VK43PNMNA

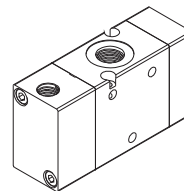
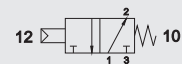

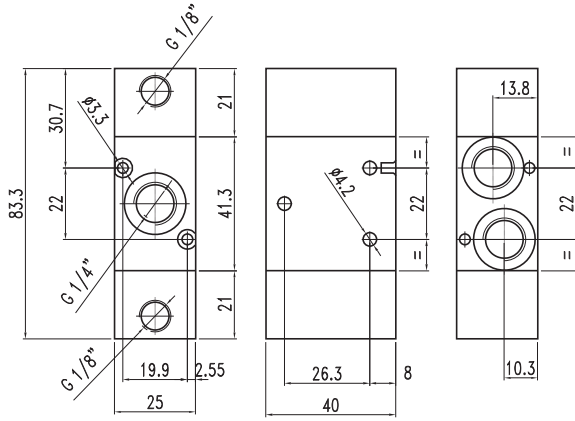

1/4 - 3/2 DOPPIO COMANDO PNEUMATICO
1/4 - 3/2 DOUBLE PNEUMATIC PILOT

CODE: VK43PNB00

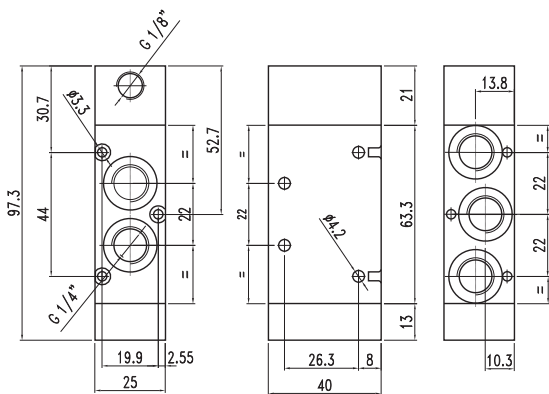
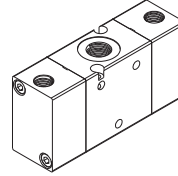
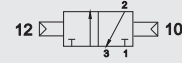

1/4 - 5/2 RITORNO A MOLLA
1/4 - 5/2 SPRING RETURN

CODE: VK45PNM00

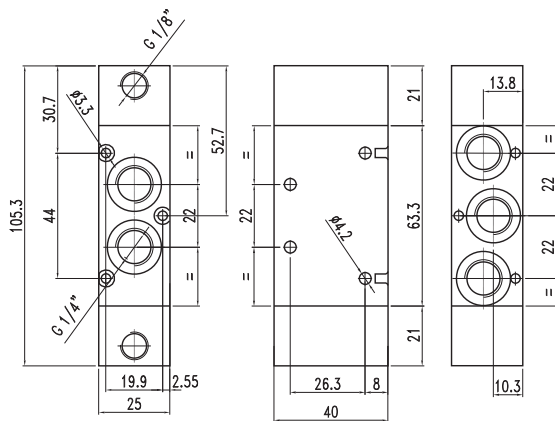
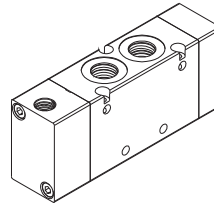
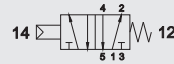

1/4 - 5/2 DOPPIO COMANDO PNEUMATICO
1/4 - 5/2 DOUBLE PNEUMATIC PILOT

CODE: VK45PNB00

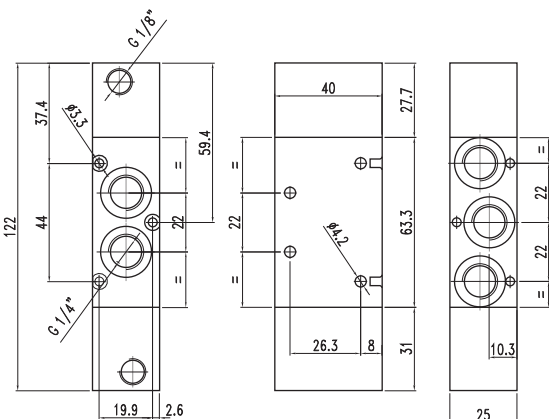
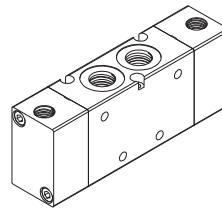
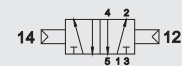

1/4 - 5/3 DOPPIO COMANDO PNEUMATICO
1/4 - 5/3 DOUBLE PNEUMATIC PILOT

CODE: VK46PNMCC CENTRI CHIUSI
CLOSED CENTRES



CODE: VK46PNMCA CENTRI APERTI
OPEN CENTRES



CODE: VK46PNMCP CENTRI IN PRESSIONE
PRESS. CENTRES



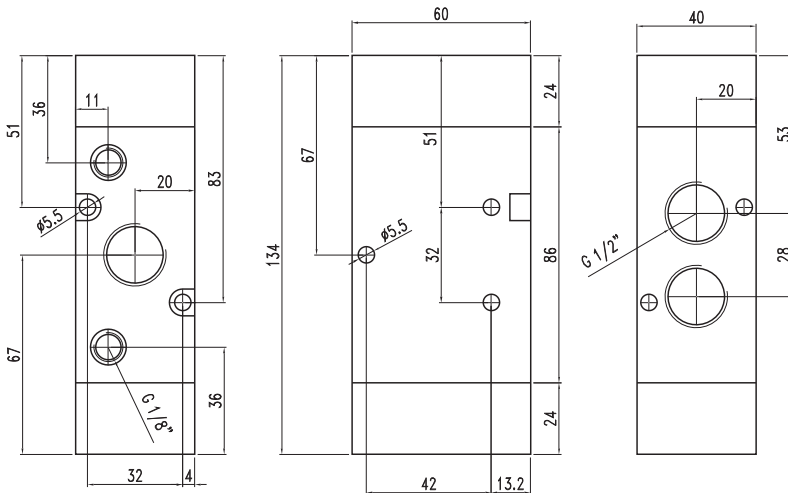

1/2 - 3/2 NC - RITORNO A MOLLA
1/2 - 3/2 NC - SPRING RETURN

CODE: VK23PNMNC

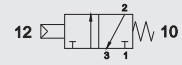

1/2 - 3/2 NA - RITORNO A MOLLA
1/2 - 3/2 NO - SPRING RETURN

CODE: VK23PNMNA

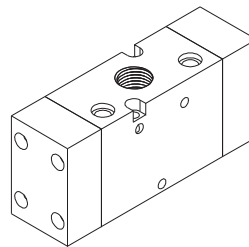
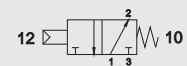

1/2 - 3/2 DOPPIO COMANDO PNEUMATICO
1/2 - 3/2 DOUBLE PNEUMATIC PILOT

CODE: VK23PNB00

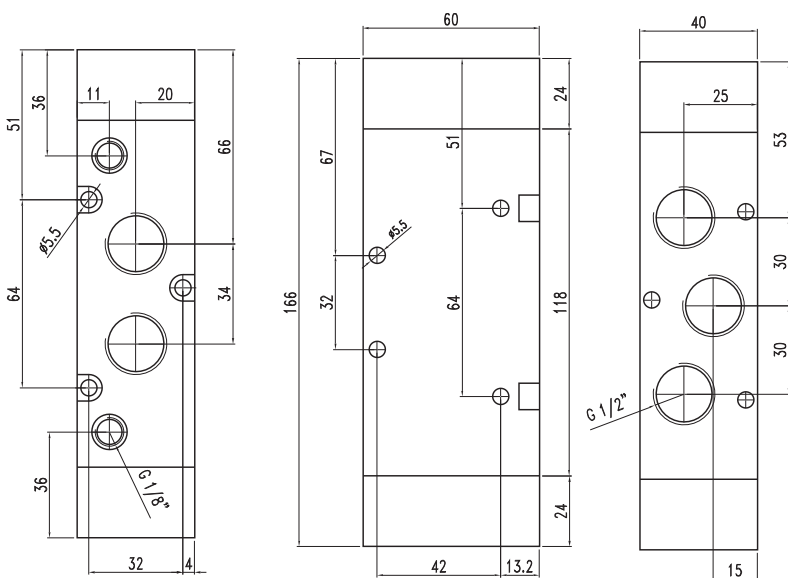
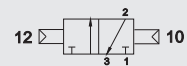

1/2 - 5/2 RITORNO A MOLLA
1/2 - 5/2 SPRING RETURN

CODE: VK25PNM00

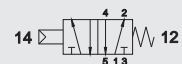

1/2 - 5/2 DOPPIO COMANDO PNEUMATICO
1/2 - 5/2 DOUBLE PNEUMATIC PILOT

CODE: VK25PNB00

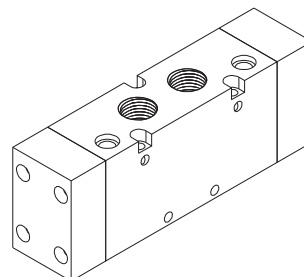

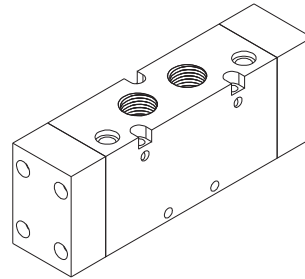
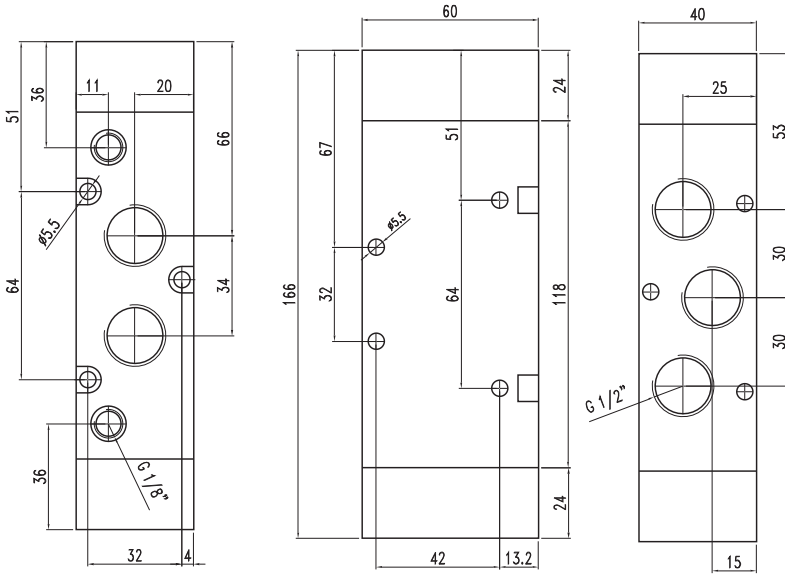

1/2 - 5/3 DOPPIO COMANDO PNEUMATICO
1/2 - 5/3 DOUBLE PNEUMATIC PILOT

CODE: VK26PNMCC CENTRI CHIUSI
CLOSED CENTRES

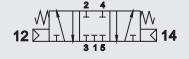

CODE: VK26PNMCA CENTRI APERTI
OPEN CENTRES



CODE: VK26PNMCP CENTRI IN PRESSIONE
PRESS. CENTRES

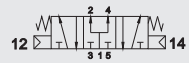

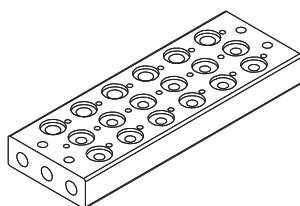
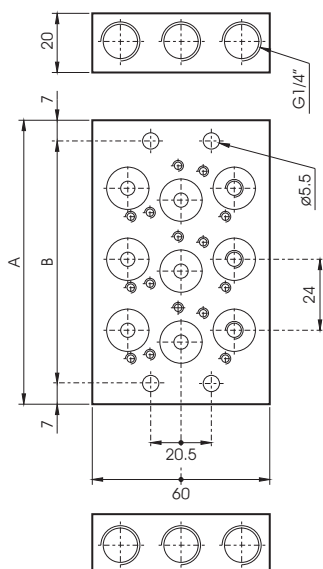

SOTTOBASE PER VALVOLE 1/8
MANIFOLD FOR 1/8 VALVES

CODE	STATIONS	A	B
SB407202	2	72	58
SB407203	3	96	82
SB407204	4	120	106
SB407205	5	144	130
SB407206	6	168	154
SB407207	7	192	178
SB407208	8	216	202
SB407209	9	240	226
SB407210	10	264	250

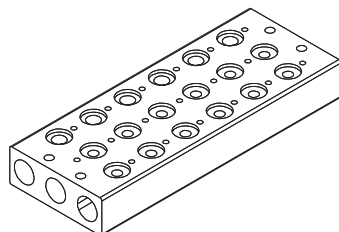
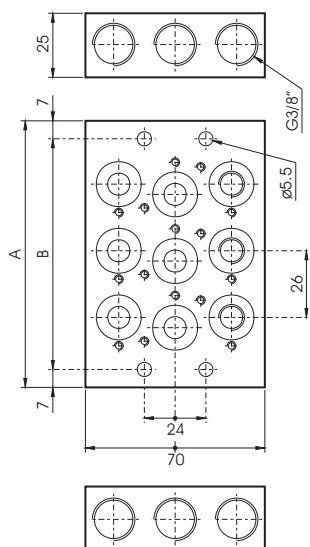

SOTTOBASE PER VALVOLE 1/4
MANIFOLD FOR 1/4 VALVES

CODE	STATIONS	A	B
SB407302	2	78	64
SB407303	3	104	90
SB407304	4	130	116
SB407305	5	156	142
SB407306	6	182	168
SB407307	7	208	194
SB407308	8	234	220

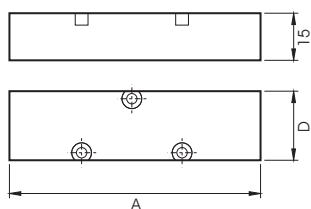

PIASTRINA DI CHIUSURA
BLANKING PLATE

CODE		A	D
SB40720004	1/8	60	22
SB40730004	1/4	70	25

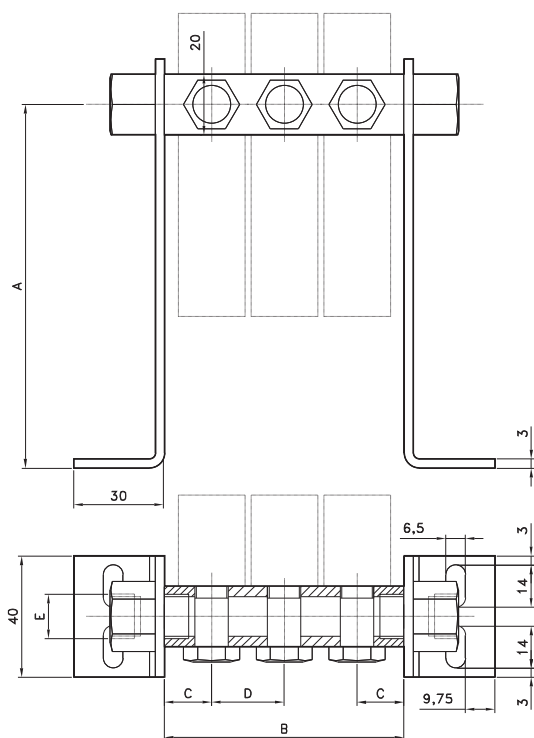
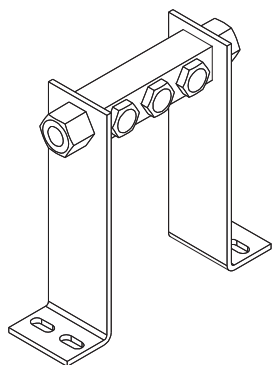

COLLETTORE 1/8
MANIFOLD 1/8

CODE	STATIONS
SB417202	2
SB417203	3
SB417204	4
SB417205	5
SB417206	6

COLLETTORE 1/4
MANIFOLD 1/4

CODE	STATIONS
SB417302	2
SB417303	3
SB417304	4
SB417305	5
SB417306	6

KIT PIEDINI 1/8
KIT PEDESTAL 1/8

CODE	A
SB4372	60
SB4472	120

KIT PIEDINI 1/4
KIT PEDESTAL 1/4

CODE	A
SB4373	60
SB4473	120

VALVOLA	A				
1/8"	120				
	60				
1/4"	120				
	60				
VALVOLA	POS.	B	C	D	E
1/8"	2	55	15.5	24	G1/4"
	3	79	15.5	24	G1/4"
	4	103	15.5	24	G1/4"
	5	127	15.5	24	G1/4"
	6	151	15.5	24	G1/4"
1/4"	2	62	17.5	27	G3/8"
	3	89	17.5	27	G3/8"
	4	116	17.5	27	G3/8"
	5	143	17.5	27	G3/8"
	6	170	17.5	27	G3/8"



Valvole ad azionamento pneumatico ed elettrico con posa di montaggio diretto NAMUR.
Costruzione interamente in alluminio per aumentare la robustezza e la durata nel tempo.
Disponibili nella taglia 1/4 e nelle funzioni 3/2 e 5/2.

Pneumatic and solenoid valves complying with NAMUR norms (direct assembly).
Valves are entirely made in aluminium, to improve the solidity and the durability.
Available size is 1/4 and available functions are 3/2 and 5/2.

DATI TECNICI / TECHNICAL DATA

Portata a 6 bar / Flow rate 6 bar	1100 NI/min
Diametro nominale / Nominal orifice	7.5mm
Tempi di risposta pneumatico / response time pneumatic	
* monostabile / mono-stable	TRA 7ms / TRR 15ms
* bistabile / bi-stable	TRA 7ms / TRR 7ms
Tempi di risposta elettrico / response time solenoid	
* monostabile / mono-stable	TRA 19ms / TRR 45ms
* bistabile / bi-stable	TRA 22ms / TRR 22ms
Pressione di esercizio / Pressure range	
* Monostabile / monostable	2.5 ÷ 10bar
* Bistabile / bistable	1 ÷ 10bar
Temperatura di esercizio / Temperature range	-10 C° ÷ +60c°

SELEZIONE RAPIDA / FAST SELECT

	PNEUMATICO - RIT. A MOLLA / PNEUMATIC - SPRING RETURN VU43PNMNC 3/2 1/4 NC		COMANDO ELETTRICO - RITORNO A MOLLA / SOLENOID PILOT - SPING RETURN VU43ELMNC 3/2 1/4 NC
	PNEUMATICO - RIT. A MOLLA / PNEUMATIC - SPRING RETURN VU45PNM00 5/2 1/4		COMANDO ELETTRICO - RITORNO A MOLLA / SOLENOID PILOT - SPING RETURN VU45ELM00 5/2 1/4
	DOPPIO COM.PNEUMATICO / DOUBLE PNEUMATIC PILOT VU43PNB00 3/2 1/4		DOPPIO COM.ELETTRICO / DOUBLE SOLENOID PILOT VU43ELB00 3/2 1/4
	DOPPIO COM.PNEUMATICO / DOUBLE PNEUMATIC PILOT VU45PNB00 5/2 1/4		DOPPIO COM.ELETTRICO / DOUBLE SOLENOID PILOT VU45ELB00 5/2 1/4

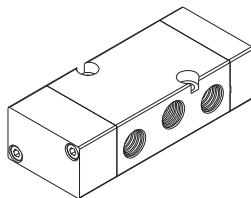
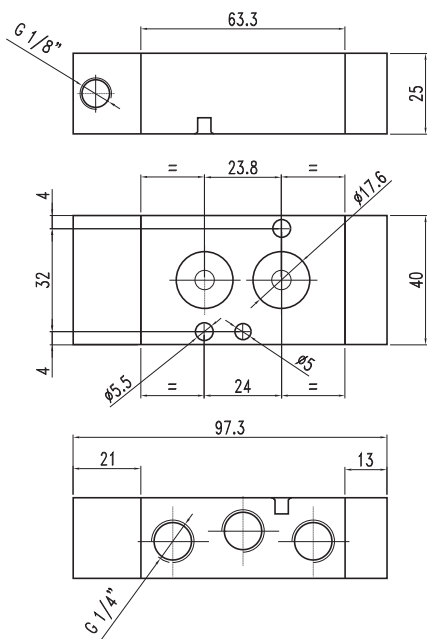

1/4 - 3/2 NC COMANDO PNEUMATICO - RITORNO A MOLLA
1/4 - 3/2 NC PNEUMATIC PILOT - SPRING RETURN

CODE: VU43PNMNC

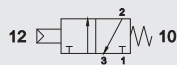

1/4 - 5/2 COMANDO PNEUMATICO - RITORNO A MOLLA
1/4 - 5/2 PNEUMATIC PILOT - SPRING RETURN

CODE: VU45PNM00

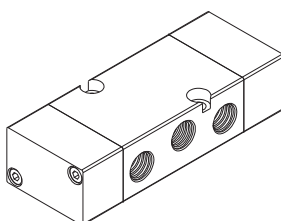
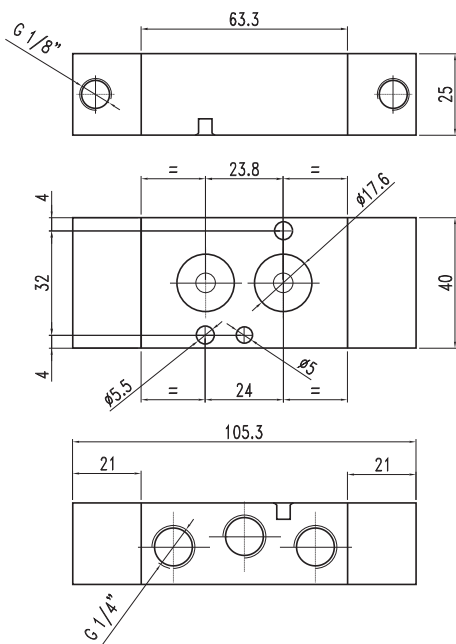

1/4 - 3/2 DOPPIO COMANDO PNEUMATICO
1/4 - 3/2 DOUBLE PNEUMATIC PILOT

CODE: VU43PNB00

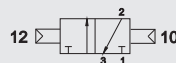

1/4 - 5/2 DOPPIO COMANDO PNEUMATICO
1/4 - 5/2 DOUBLE PNEUMATIC PILOT

CODE: VU45PNB00

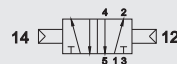

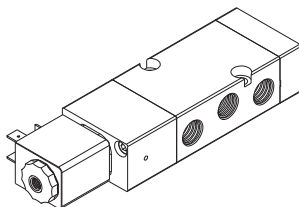
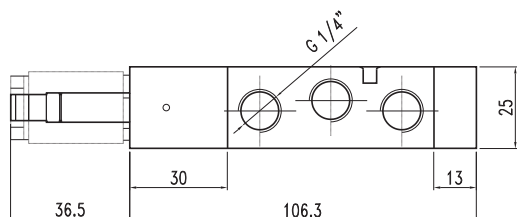
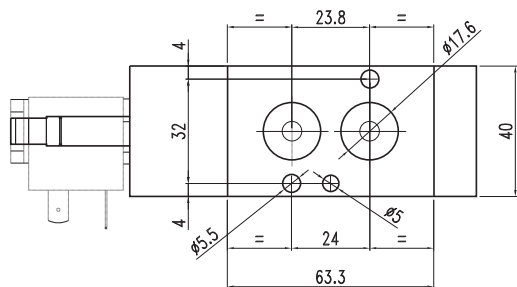

1/4 - 3/2 NC COMANDO ELETTRICO - RITORNO A MOLLA
1/4 - 3/2 NC SOLENOID PILOT - SPRING RETURN

CODE: VU43ELMNC

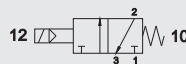

1/4 - 5/2 COMANDO ELETTRICO - RITORNO A MOLLA
1/4 - 5/2 SOLENOID PILOT - SPRING RETURN

CODE: VU45ELM00

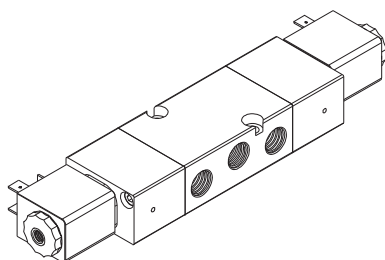
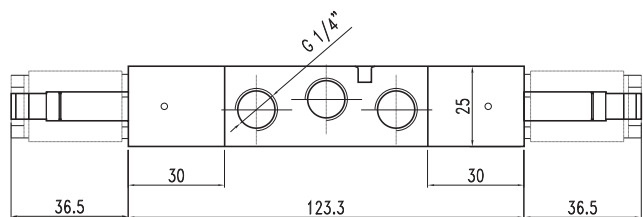
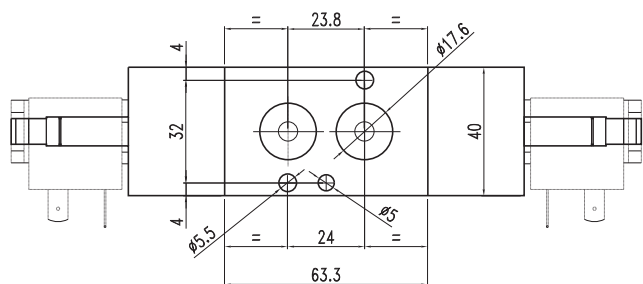

1/4 - 3/2 DOPPIO COMANDO ELETTRICO
1/4 - 3/2 DOUBLE SOLENOID PILOT

CODE: VU43ELB00

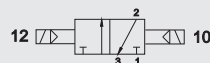

1/4 - 5/2 DOPPIO COMANDO ELETTRICO
1/4 - 5/2 DOUBLE SOLENOID PILOT

CODE: VU45ELB00



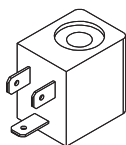
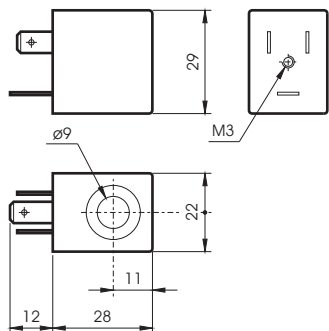

BOBINE
COILS

CODE	Tensione Tension	Assorbimento /Power a regime Rated	di spunto Inrush
BO4011024	24 VDC	3W	
BO4012024	24 VAC	5VA	7,5VA
BO4012110	110 VAC	5VA	7,5VA
BO4012220	220 VAC	5VA	7,5VA

CARATTERISTICHE TECNICHE / TECHNICAL SPECIFICATIONS

Tolleranza di tensione / Tension tolerance	+10%
Protezione con connettore / Protection with connector	IP65
Temperatura max di esercizio / Max working temperature	+50 C°
Inserimento / Duty cycle	ED 100%

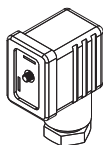
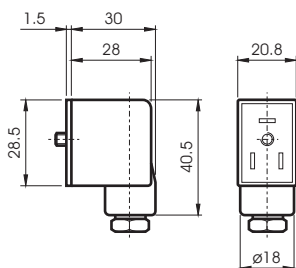

CONNETTORI
CONNECTORS

CODE	
AR40696	STANDARD
VX0014	LED 24V
VX0015	LED 110V
VX0016	LED 220V
VX0017	LED+VDR di protezione 24V
VX0018	LED+VDR di protezione 110V
VX0019	LED+VDR di protezione 220V

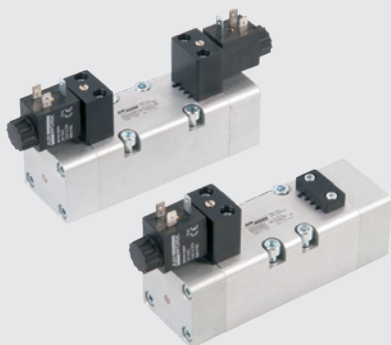

Le valvole della serie VI sono realizzate per rispondere alla normativa 5599/1. Costruzione interamente in alluminio per garantire solidità e lunga durata. Sono disponibili nella tagli ISO 1 e ISO 2 con diverse configurazioni di sottobasi.

The VI Series complies with ISO 5599/1 norms. They are entirely made in aluminium in order to grant strength and long durability. They are available in ISO 1 and ISO 2 with different bases according to the different applications.

DATI TECNICI / TECHNICAL DATA

Fluido / Fluid	Aria con o senza lubrificazione / lubricated or non lubricated air	
Temperatura di esercizio / Temperature range	-10° +60°C	
Pressione di azionamento / Actuating pressure		
- monostabile / mono-stable	2,5 - 10bar	
- bistabile / bi-stable	1 - 10bar	
	ISO 1	ISO 2
Diametro nominale / Nominal orifice	7,5mm	9mm
Portata a 6 bar / Flow rates 6 bar	1100 NI/min	2700 NI/min
TRA / TRR monostabile a 6bar	24ms / 50ms	39ms / 60ms
TRA / TRR bistabile a 6bar	80ms / 80ms	90ms / 90ms

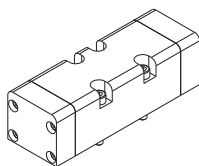
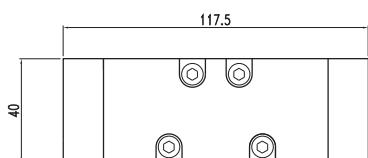
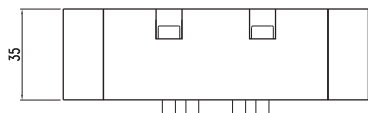

ISO 1 COMANDO PNEUMATICO / PNEUMATIC PILOT

CODE: VI115010	5/2 MONOSTABILE 5/2 MONOSTABLE	
CODE: VI115020	5/2 BISTABILE 5/2 BISTABLE	
CODE: VI116021	5/3 CENTRI CHIUSI 5/3 CLOSED CENTRES	
CODE: VI116022	5/3 CENTRI APERTI 5/3 OPEN CENTRES	
CODE: VI116023	5/3 CENTRI IN PRESSIONE 5/3 PRESS.CENTRES	

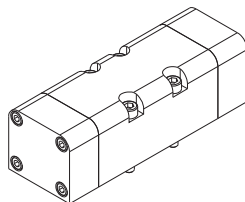
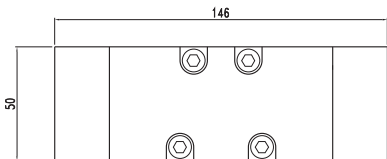
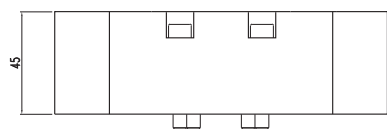

ISO 2 COMANDO PNEUMATICO / PNEUMATIC PILOT

CODE: VI125010	5/2 MONOSTABILE 5/2 MONOSTABLE	
CODE: VI125020	5/2 BISTABILE 5/2 BISTABLE	
CODE: VI126021	5/3 CENTRI CHIUSI 5/3 CLOSED CENTRES	
CODE: VI126022	5/3 CENTRI APERTI 5/3 OPEN CENTRES	
CODE: VI126023	5/3 CENTRI IN PRESSIONE 5/3 PRESS.CENTRES	

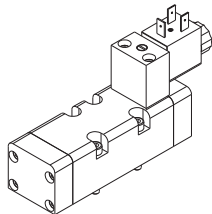
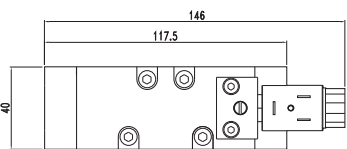
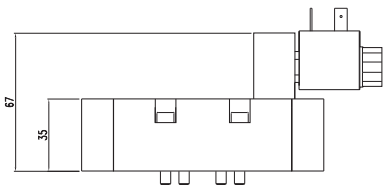

ISO 1
COMANDO ELETTRICO, RITORNO A MOLLA
SOLENOID PILOT, SPRING RETURN

CODE: VI215030 14  12

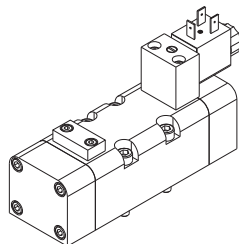
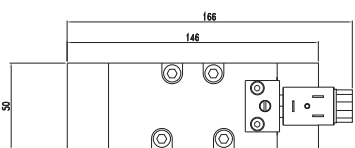
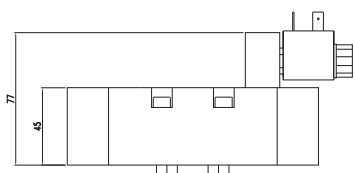

ISO 2
COMANDO ELETTRICO, RITORNO A MOLLA
SOLENOID PILOT, SPRING RETURN

CODE: VI225030 14  12

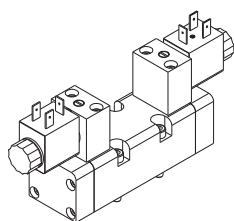
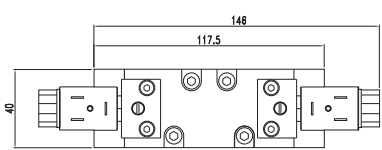
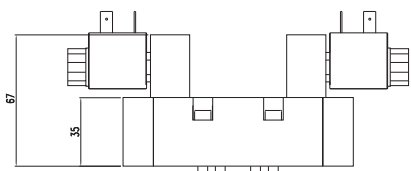

ISO 1
DOPPIO COMANDO ELETTRICO
DOUBLE SOLENOID PILOT

CODE: VI215040 5/2 MONOSTABILE
5/2 MONOSTABLE  12

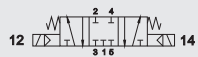
CODE: VI216041 5/3 CENTRI CHIUSI
5/3 CLOSED CENTRES  14

CODE: VI216042 5/3 CENTRI APERTI
5/3 OPEN CENTRES  14

CODE: VI216043 5/3 CENTRI IN PRESSIONE
5/3 PRESS.CENTRES  14

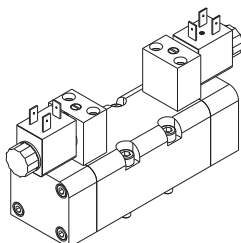
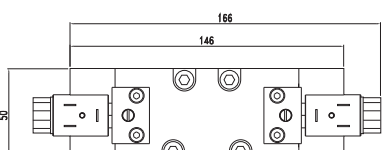
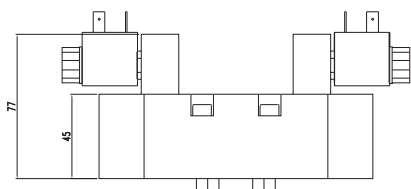

ISO 2
DOPPIO COMANDO ELETTRICO
DOUBLE SOLENOID PILOT

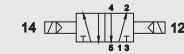
CODE: VI225040 5/2 MONOSTABILE
5/2 MONOSTABLE  12

CODE: VI226041 5/3 CENTRI CHIUSI
5/3 CLOSED CENTRES  14

CODE: VI226042 5/3 CENTRI APERTI
5/3 OPEN CENTRES  14

CODE: VI226043 5/3 CENTRI IN PRESSIONE
5/3 PRESS.CENTRES  14

SOTTOBASE MODULARE ISO 1
MODULAR SUB-BASE ISO 1

CODE: SB40401100

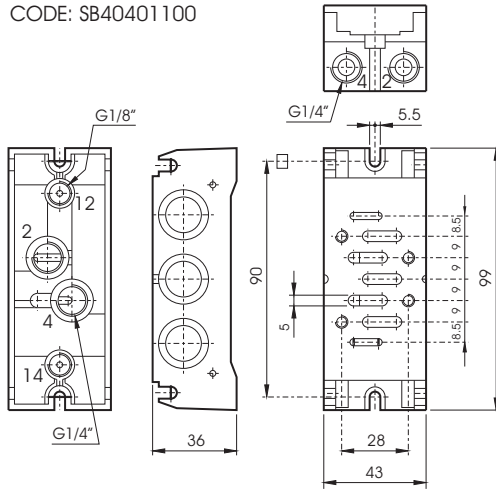

SOTTOBASE MODULARE ISO 2
MODULAR SUB-BASE ISO 2

CODE: SB40461100

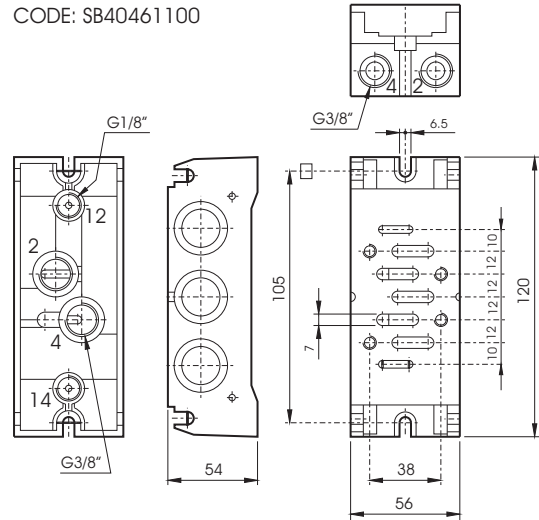

TERMINALE DI INGRESSO IN ASSE ISO 1
SIDE ENTRY HEADER ISO 1

CODE: SB40400001

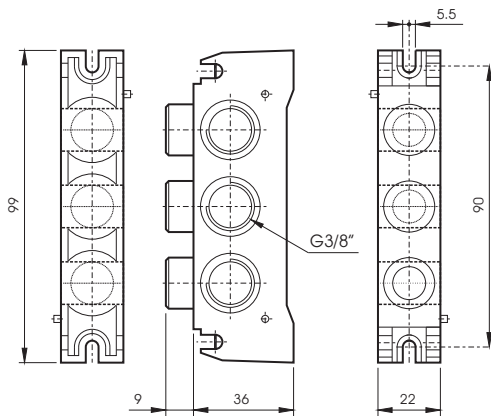

TERMINALE DI INGRESSO IN ASSE ISO 2
SIDE ENTRY HEADER ISO 2

CODE: SB40460001

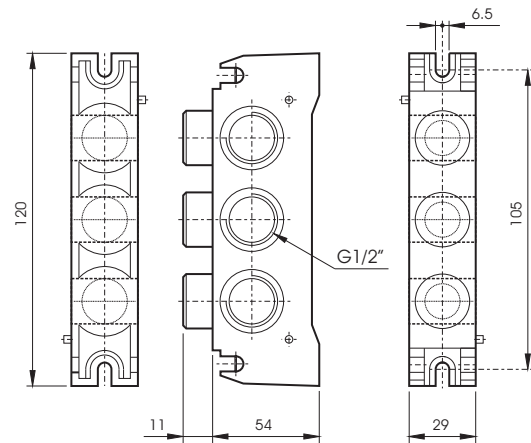

TERMINALE DI INGRESSO INFERIORE ISO 1
BOTTOM ENTRY HEADER ISO 1

CODE: SB40400003

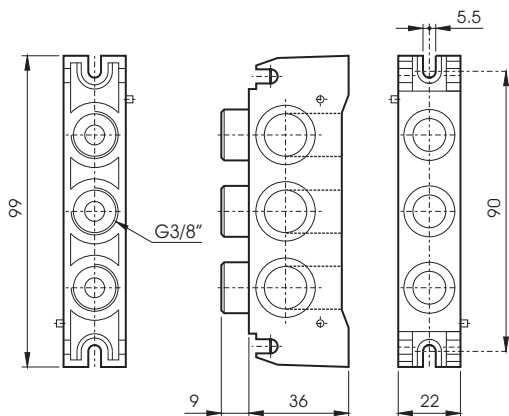

TERMINALE DI INGRESSO INFERIORE ISO 2
BOTTOM ENTRY HEADER ISO 2

CODE: SB40460003

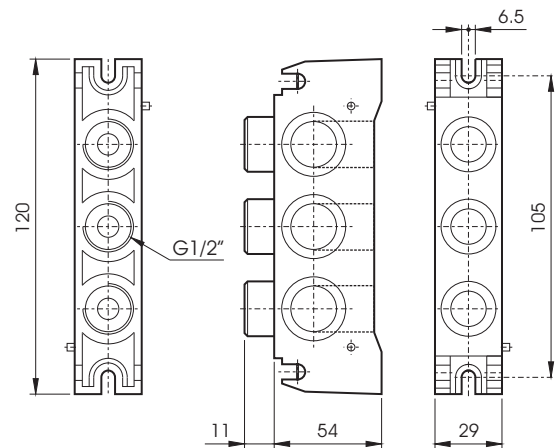

TERMINALE DI INGRESSO SUPERIORE ISO 1
TOP ENTRY HEADER ISO 1

CODE: SB40400002

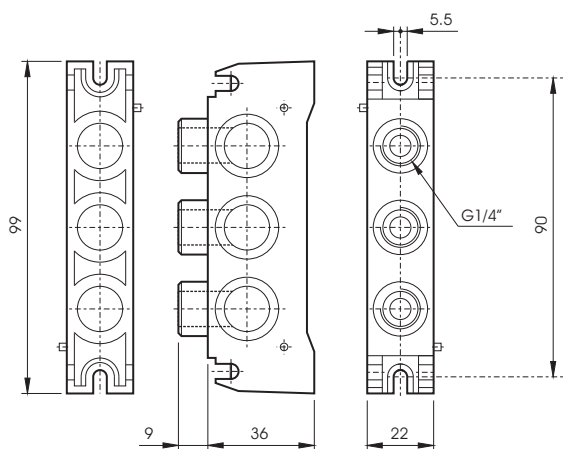

TERMINALE DI INGRESSO SUPERIORE ISO 2
TOP ENTRY HEADER ISO 2

CODE: SB40460002

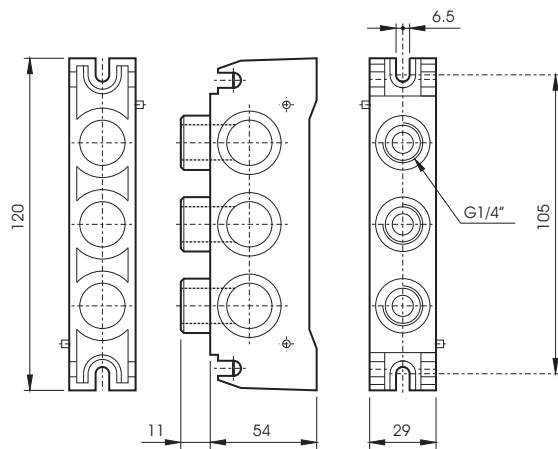

TERMINALE DI INGRESSO IN ASSE ISO 1
SIDE ENTRY HEADER ISO 1

CODE: SB40400011

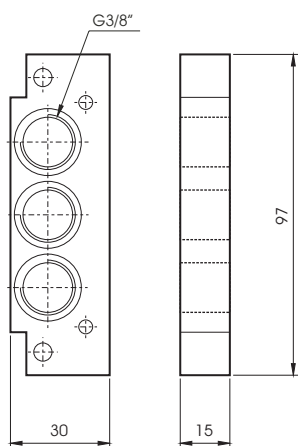

TERMINALE CIECO ISO 1
BLIND HEADER ISO 1

CODE: SB40400006

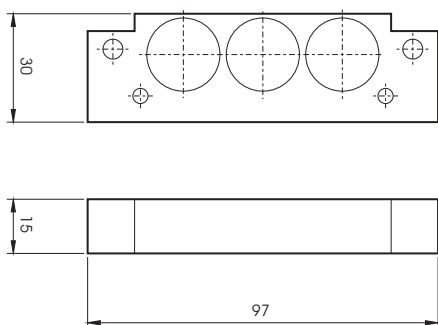

PIASTRINA DI CHIUSURA ISO 1
BLANKING PLATE ISO 1

CODE: SB40400004

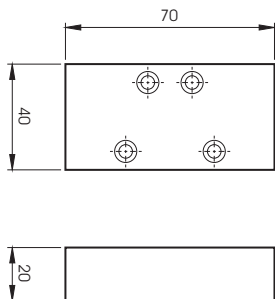

SOTTOBASE SINGOLA ISO 1
SINGLE SUB-BASE ISO 1

CODE: SB40400100

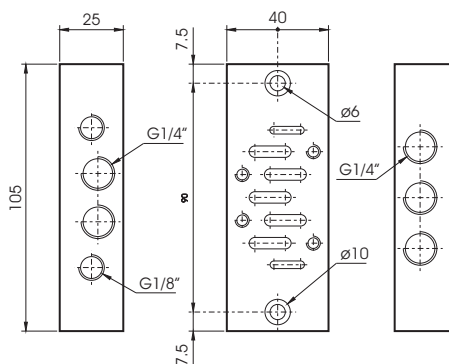

BOBINE 22mm
COILS 22mm

CODE	Tensione Tension	assorbimento a regime Rated	power di spunto Inrush
BO4011024	24 VDC	3W	
BO4012024	24 VAC	5VA	7,5VA
BO4012110	110 VAC	5VA	7,5VA
BO4012220	220 VAC	5VA	7,5VA

CONNETTORI
CONNECTORS

CODE	
AR40696	STANDARD
VX0014	LED 24V
VX0015	LED 110V
VX0016	LED 220V
VX0017	LED+VDR
VX0018	LED+VDR
VX0019	LED+VDR

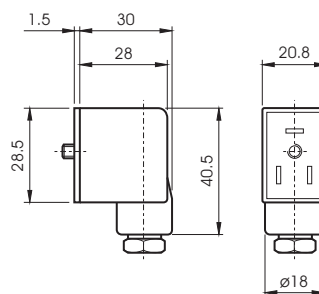
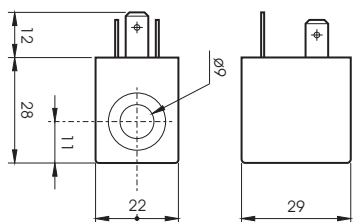

BOBINE 30mm
COILS 30mm

CODE	Tensione Tension	assorbimento a regime Rated	power di spunto Inrush
BO4021024	24 VDC	2W	
BO4022024	24 VAC	5VA	9VA
BO4022110	110 VAC	5VA	9VA
BO4020220	220 VAC	5VA	9VA

CONNETTORI
CONNECTORS

CODE	
VX0027	STANDARD
VX0028	LED 24V
VX0029	LED 110V
VX0030	LED 220V
VX0031	LED+VDR
VX0032	LED+VDR
VX0033	LED+VDR

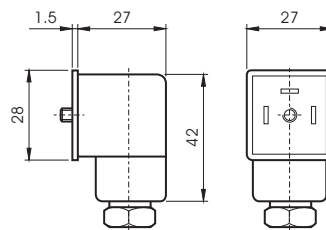
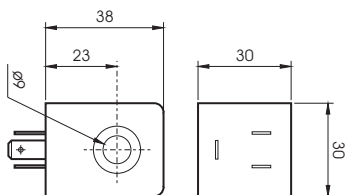



Vastissima gamma di valvole manuali caratterizzate da diverse tipologie di azionamenti: leva 90°, leva in testa, tiretto, con adattatore per ospitare tutti i tipi di attuatori a pannello.

Sono disponibili nelle taglie 1/8 e 1/4 e nelle funzioni 3/2, 5/2 e 5/3.

Costruzione interamente in alluminio per garantire robustezza e durata nel tempo.

Extended range of manual valves with different operations: 90° lever, lever on top, drawer, with adaptor for all actuators on panel.

Available in size 1/8 and 1/4, available functions are 3/2, 5/2, 5/3.

Entirely in aluminium to grant strength and long durability.

DATI TECNICI / TECHNICAL DATA

Fluido / Fluid	Aria con o senza lubrificazione / Lubricated or non lubricated air
Temperatura di esercizio / Operating temperature range	Max +60C°
Pressione massima di esercizio / Max operating pressure	10 bar
Diametro nominale / Nominal orifice	1/8: 5 mm - 1/4: 7,5mm
Portata a 6 bar / Flow rates 6bar	1/8=550 Nl/min. / 1/4=1100 Nl/min

SELEZIONE RAPIDA / FAST SELECT

	LEVA 90° - RIT. A MOLLA / 90° LEVER - SPRING RETURN VM4010083201 3/2 1/8 NC VM4010083301 3/2 1/4 NC		TIRETTO - RIT. A MOLLA / PUSH/PULL SPING RETURN VM4010095201 5/2 1/8 VM4010095301 5/2 1/4
	LEVA 90° - RIT. A MOLLA / 90° LEVER - SPRING RETURN VM4010085201 5/2 1/8 VM4010085301 5/2 1/4		TIRETTO - BISTABILE / BISTABLE PUSH/PULL VM4010093202 3/2 1/8 NC VM4010093302 3/2 1/4 NC
	LEVA 90° - BISTABILE / 90° BISTABLE LEVER VM4010083202 3/2 1/8 NC VM4010083302 3/2 1/4 NC		TIRETTO - BISTABILE / BISTABLE PUSH/PULL VM4010095202 5/2 1/8 VM4010095302 5/2 1/4
	LEVA 90° - BISTABILE / 90° BISTABLE LEVER VM4010085202 5/2 1/8 VM4010085302 5/2 1/4		LEVA IN TESTA BISTABILE / BISTABLE TOP LEVER VM4010103202 3/2 1/8 NC VM4010103302 3/2 1/4 NC
	LEVA 90° - RIT. AL CENTRO / 90° LEVER - RET. TO CENTRE VM4010086211 5/3 1/8 CC VM4010086311 5/3 1/4 CC		LEVA IN TESTA BISTABILE / BISTABLE TOP LEVER VM4010105202 5/2 1/8 VM4010105302 5/2 1/4
	LEVA 90° - RIT. AL CENTRO / 90° LEVER - RET. TO CENTRE VM4010086221 5/3 1/8 CA / CO VM4010086321 5/3 1/4 CA / CO		ADATTATORE IN TESTA / ADAPTOR IN TOP VM4012023201 3/2 1/8 NC
	LEVA 90° - RIT. AL CENTRO / 90° LEVER - RET. TO CENTRE VM4010086231 5/3 1/8 CP VM4010086331 5/3 1/4 CP		ADATTATORE IN TESTA / ADAPTOR IN TOP VM4011023201 3/2 1/8 NA / NO
	LEVA 90° - 3 POS. STABILI / 90° LEVER - 3 DETENTED POS. VM4010086212 5/3 1/8 CC VM4010086312 5/3 1/4 CC		ADATTATORE IN TESTA / ADAPTOR IN TOP VM4010025201 5/2 1/8
	LEVA 90° - 3 POS. STABILI / 90° LEVER - 3 DETENTED POS. VM4010086222 5/3 1/8 CA / CO VM4010086322 5/3 1/4 CA / CO		ADATTATORE A 90° / 90° ADAPTOR VM4012193201 3/2 1/8 NC
	LEVA 90° - 3 POS. STABILI / 90° LEVER - 3 DETENTED POS. VM4010086232 5/3 1/8 CP VM4010086332 5/3 1/4 CP		ADATTATORE A 90° / 90° ADAPTOR VM4011193201 3/2 1/8 NA / NO
	TIRETTO - RIT. A MOLLA / PUSH/PULL WITH SPING RETURN VM4010093201 3/2 1/8 NC VM4010093301 3/2 1/4 NC		ADATTATORE A 90° / 90° ADAPTOR VM4010195201 5/2 1/8

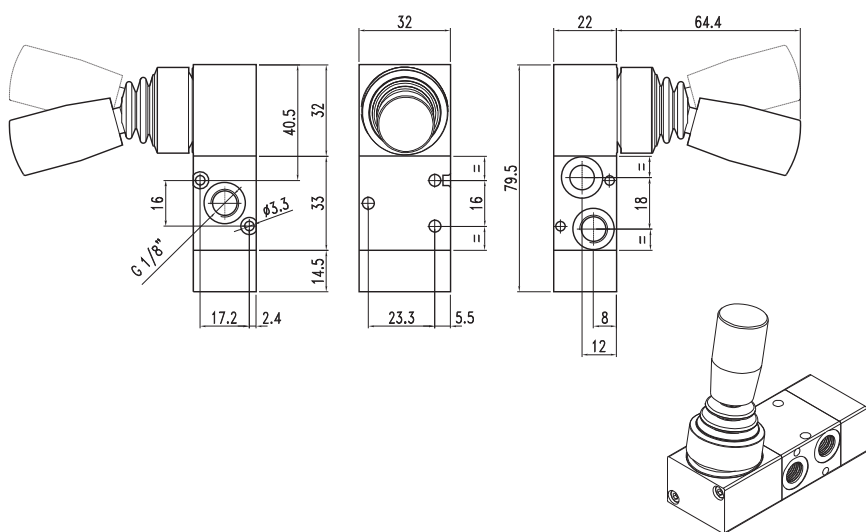

1/8 - 3/2 NC - LEVA 90°, RITORNO A MOLLA
1/8 - 3/2 NC - 90° LEVER, SPRING RETURN

CODE: VM4010083201

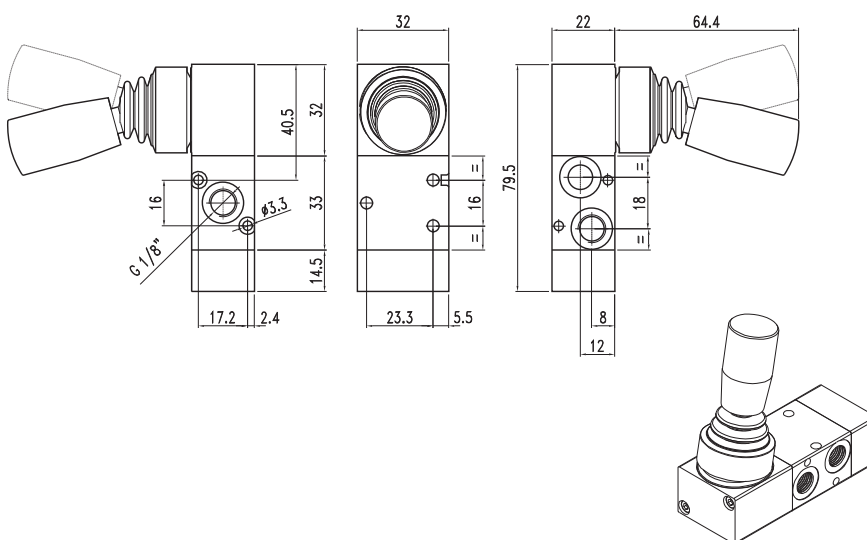
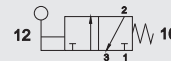

1/8 - 3/2 NC - LEVA 90°, BISTABILE
1/8 - 3/2 NC - 90° LEVER, BISTABLE

CODE: VM4010083202

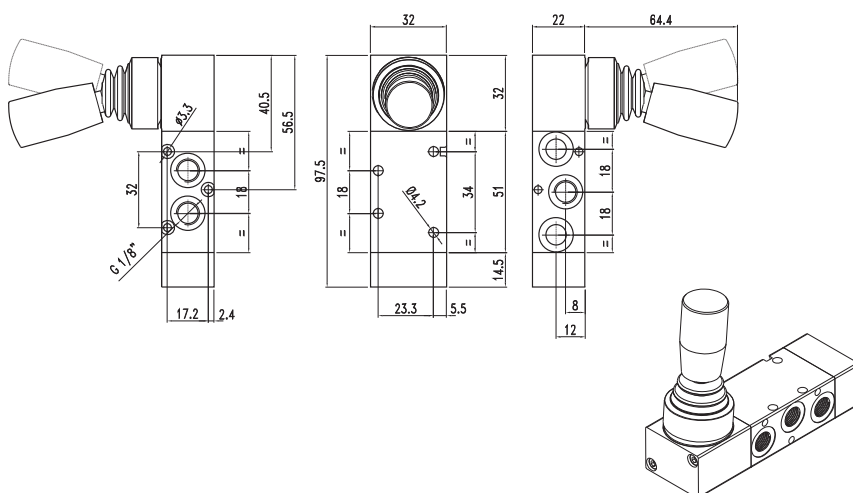
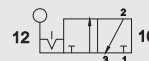

1/8 - 5/2 LEVA 90°, RITORNO A MOLLA
1/8 - 5/2 90° LEVER, SPRING RETURN

CODE: VM4010085201



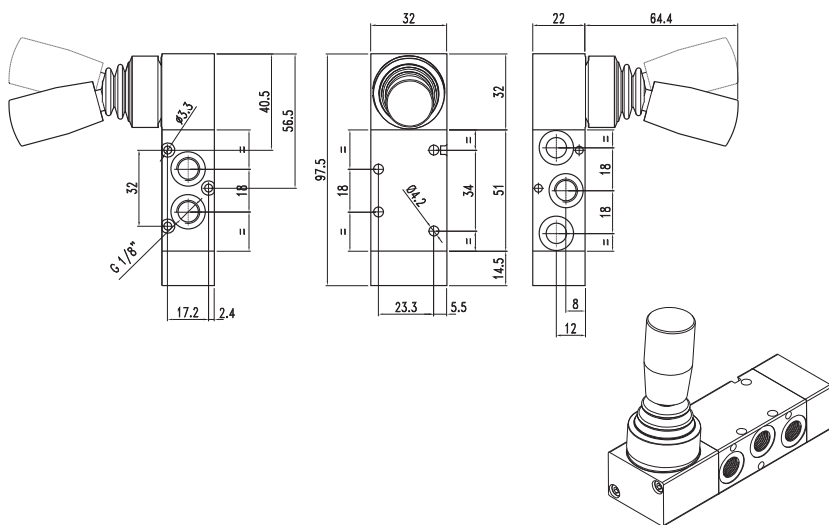

1/8 - 5/2 LEVA 90°, BISTABILE
1/8 - 5/2 90° LEVER, BISTABLE

CODE: VM4010085202

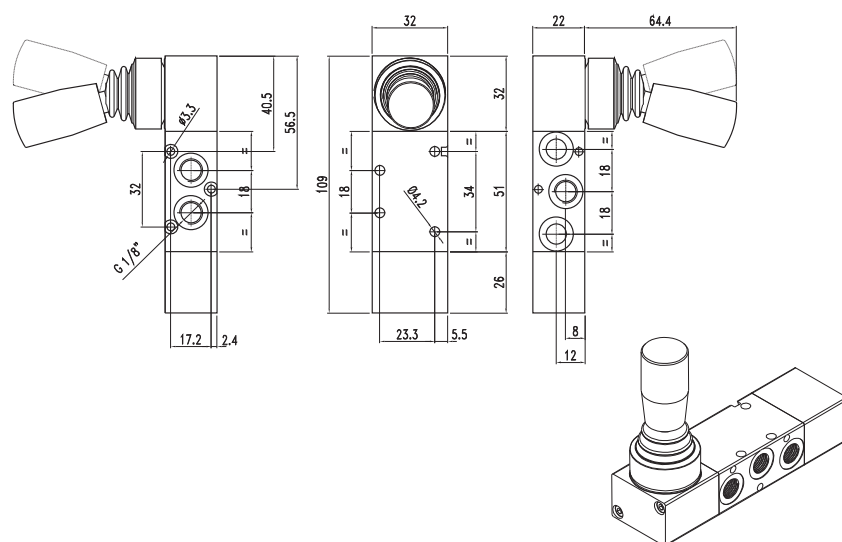

1/8 - 5/3 LEVA 90°, RITORNO AL CENTRO
1/8 - 5/3 90° LEVER, SPRING RET. TO CENTRE

CODE: VM4010086211

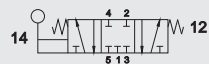

CODE: VM4010086221



CODE: VM4010086231

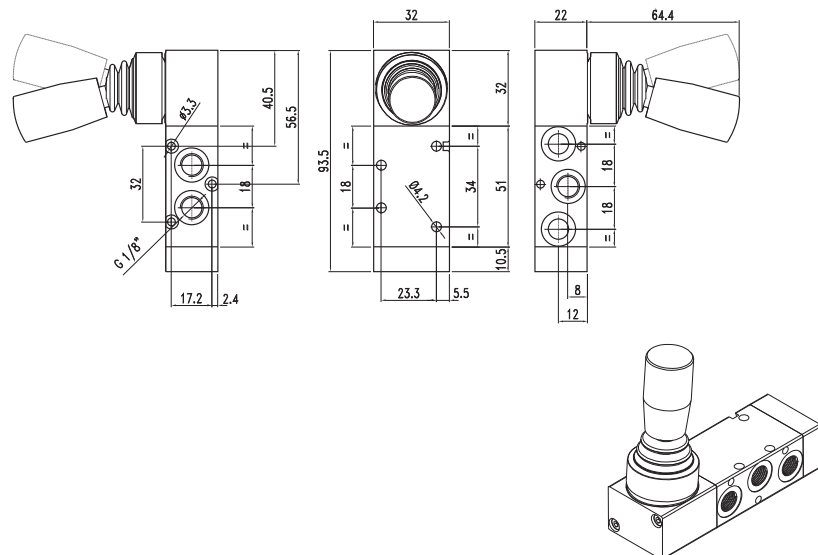

1/8 - 5/3 LEVA 90°, TRE POSIZIONI STABILI
1/8 - 5/3 90° LEVER, THREE DETENTED POSITIONS

CODE: VM4010086212

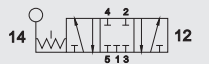

CODE: VM4010086222



CODE: VM4010086232

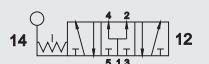

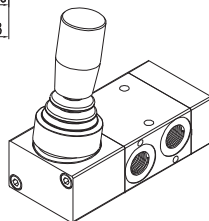
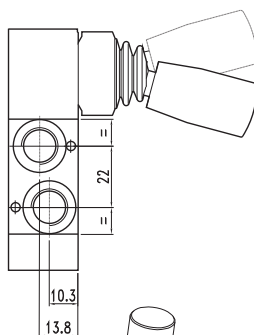
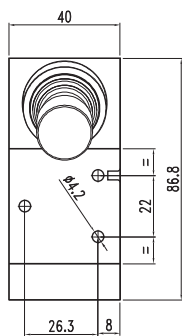
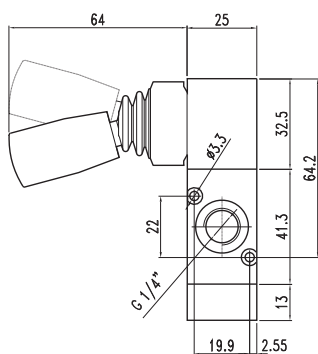

1/4 - 3/2 NC - LEVA 90°, RITORNO A MOLLA
1/4 - 3/2 NC - 90° LEVER, SPRING RETURN

CODE: VM4010083301

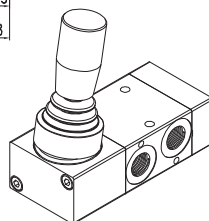
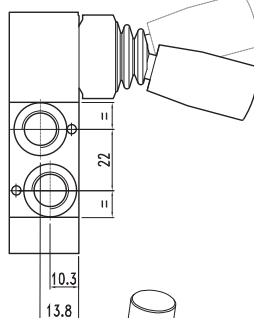
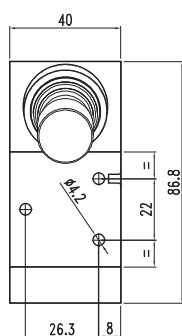
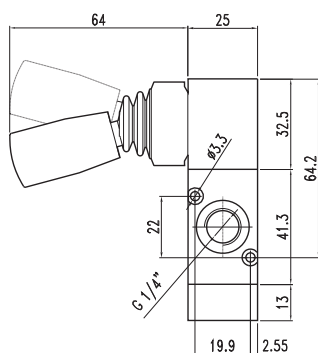
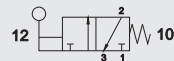

1/4 - 3/2 NC - LEVA 90°, BISTABILE
1/4 - 3/2 NC - 90° LEVER, BISTABLE

CODE: VM4010083302

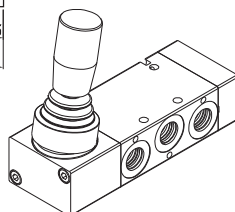
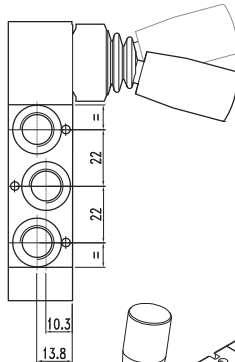
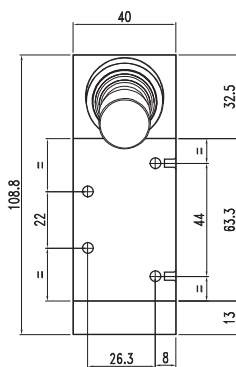
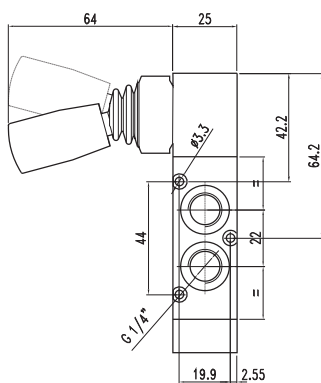
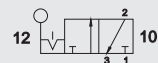

1/4 - 5/2 LEVA 90°, RITORNO A MOLLA
1/4 - 5/2 90° LEVER, SPRING RETURN

CODE: VM4010085301



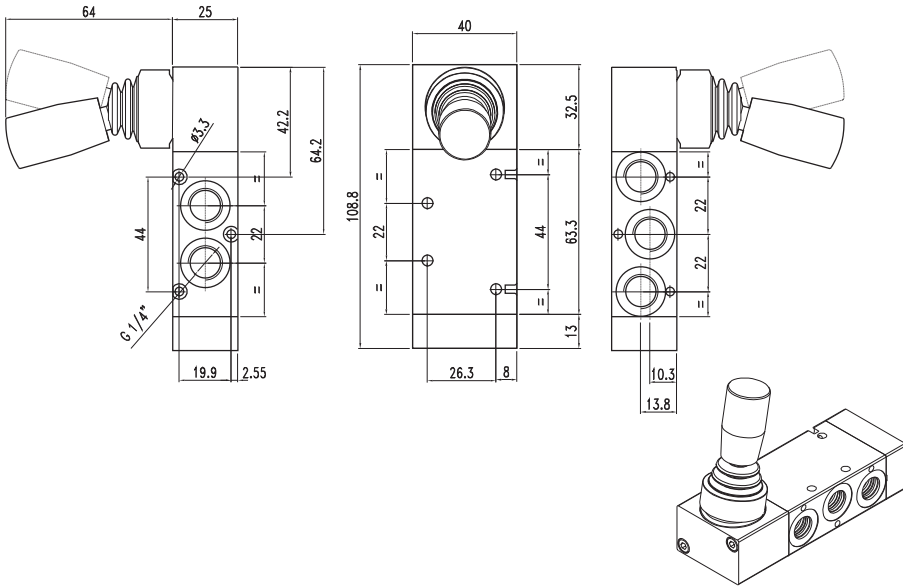

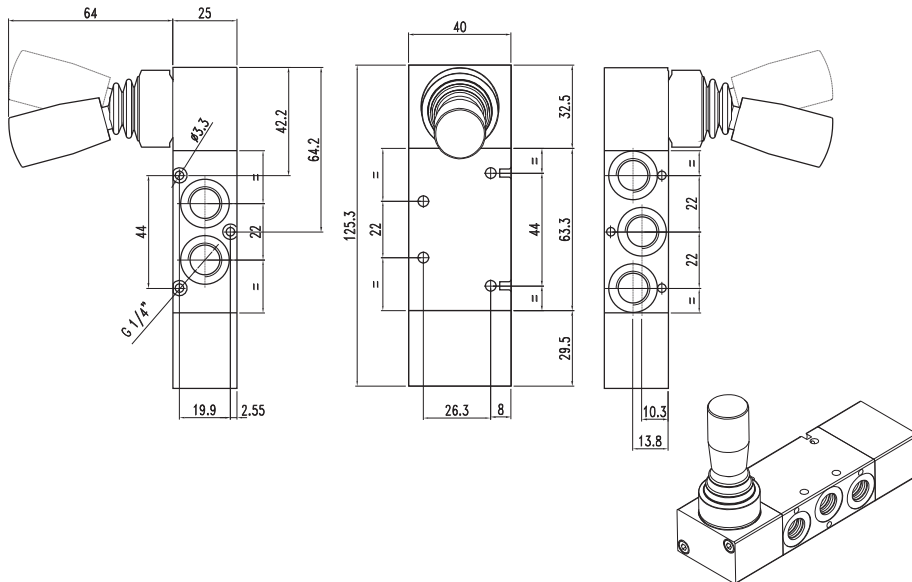

1/4 - 5/2 LEVA 90°, BISTABILE
1/4 - 5/2 90° LEVER, BISTABLE

CODE: VM4010085302

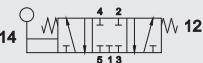

1/4 - 5/3 LEVA 90°, RITORNO AL CENTRO
1/4 - 5/3 90° LEVER, SPRING RETURN TO CENTRE

CODE: VM4010086311 

CODE: VM4010086321 

CODE: VM4010086331 

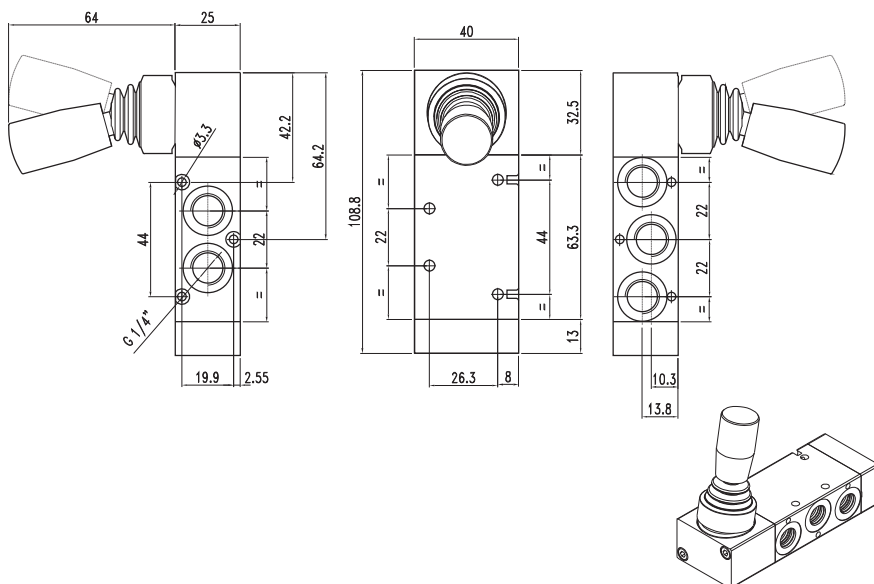

1/4 - 5/3 LEVA 90°, TRE POSIZIONI STABILI
1/4 - 5/3 90° LEVER, THREE DETENTED POSITINS

CODE: VM4010086312 

CODE: VM4010086322 

CODE: VM4010086332 

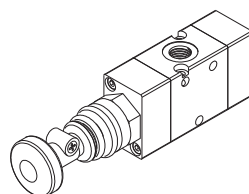
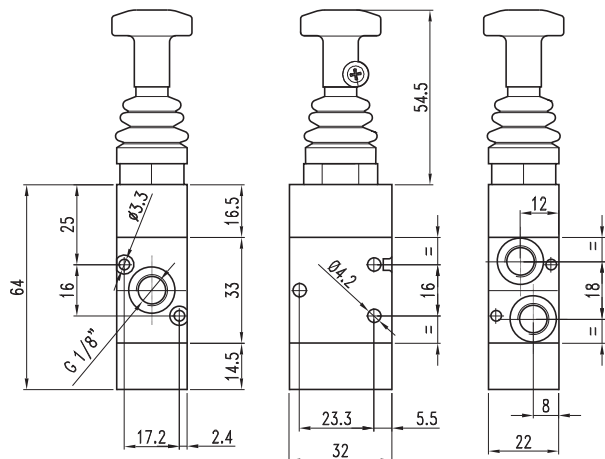

1/8 - 3/2 NC - TIRETTO, RITORNO A MOLLA
1/8 - 3/2 NC - PUSH/PULL, SPING RETURN

CODE: VM4010093201

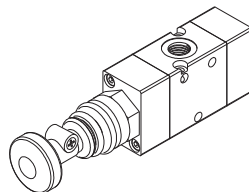
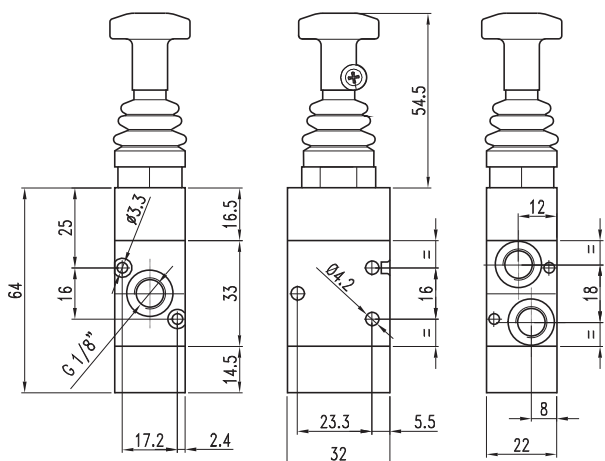
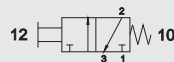

1/8 - 3/2 NC - TIRETTO, BISTABILE
1/8 - 3/2 NC - PUSH/PULL, BISTABILE

CODE: VM4010093202

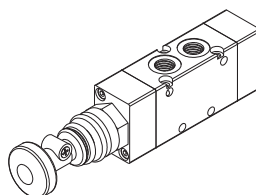
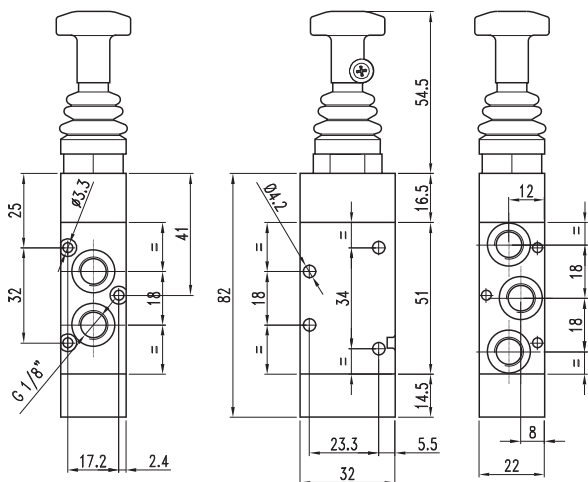
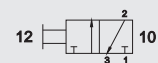

1/8 - 5/2 TIRETTO, RITORNO A MOLLA
1/8 - 5/2 PUSH/PULL, SPING RETURN

CODE: VM4010095201



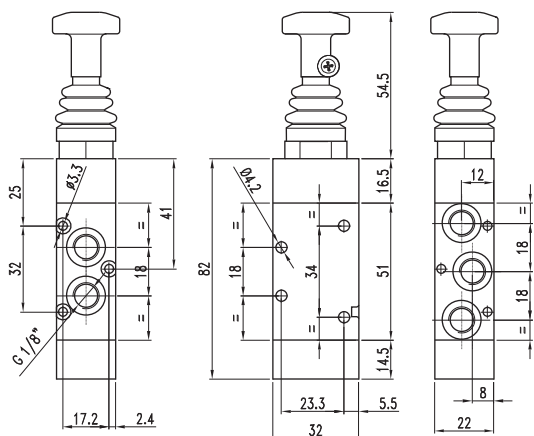

1/8 - 5/2 TIRETTO, BISTABILE
1/8 - 5/2 PUSH/PULL, BISTABLE

CODE: VM4010095202

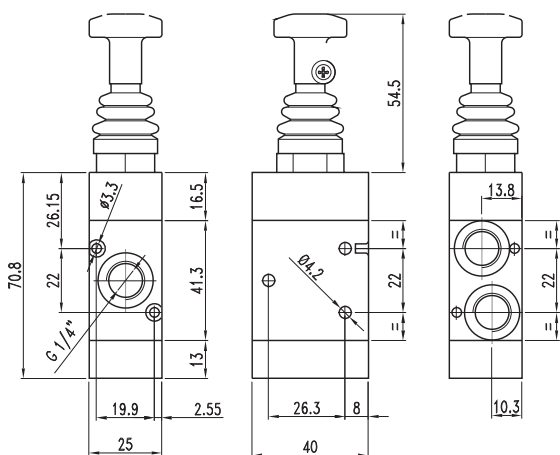

1/4 - 3/2 NC - TIRETTO, RITORNO A MOLLA
1/4 - 3/2 NC - PUSH/PULL, SPING RETURN

CODE: VM4010093301

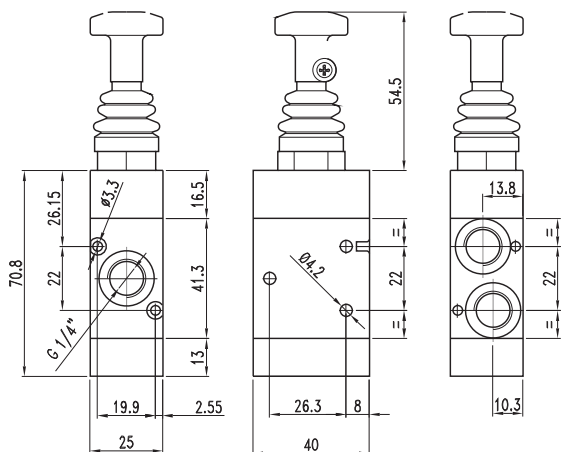
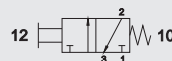

1/4 - 3/2 NC - TIRETTO, BISTABILE
1/4 - 3/2 NC - PUSH/PULL, BISTABILE

CODE: VM4010093302

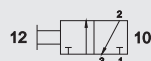

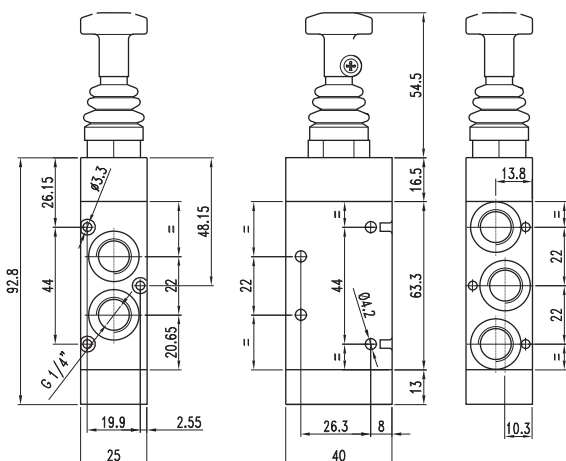

1/4 - 5/2 TIRETTO, RITORNO A MOLLA
1/4 - 5/2 PUSH/PULL, SPING RETURN

CODE: VM4010095301

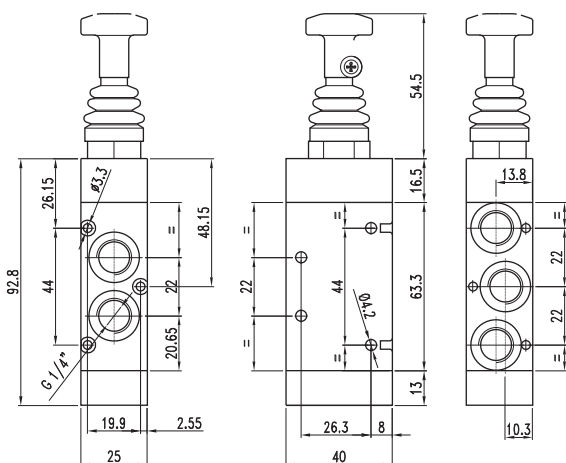
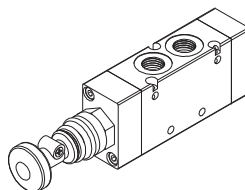
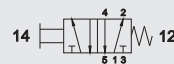

1/4 - 5/2 TIRETTO, BISTABILE
1/4 - 5/2 PUSH/PULL, BISTABILE

CODE: VM4010095302

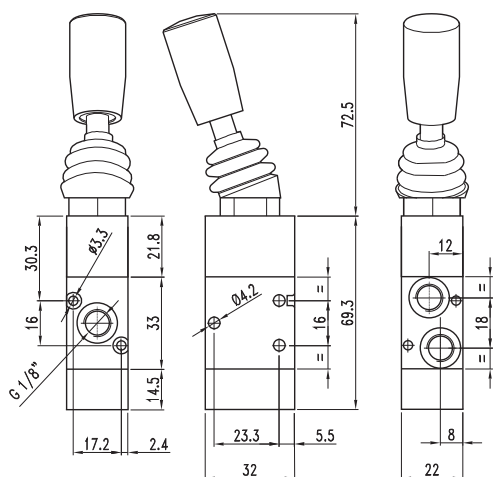
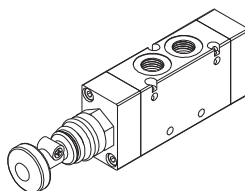
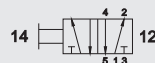

1/8 - 3/2 NC - LEVA IN TESTA, BISTABILE
1/8 - 3/2 NC - TOP LEVER, BISTABILE

CODE: VM4010103202

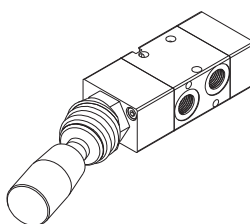
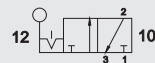

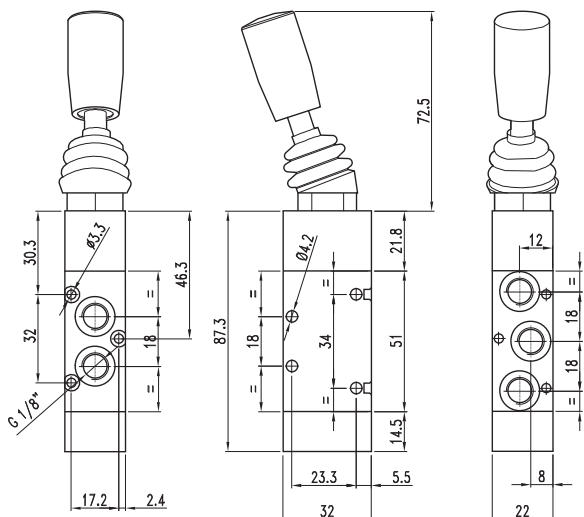

1/8 - 5/2 LEVA IN TESTA, BISTABILE
1/8 - 5/2 TOP LEVER, BISTABLE

CODE: VM4010105202

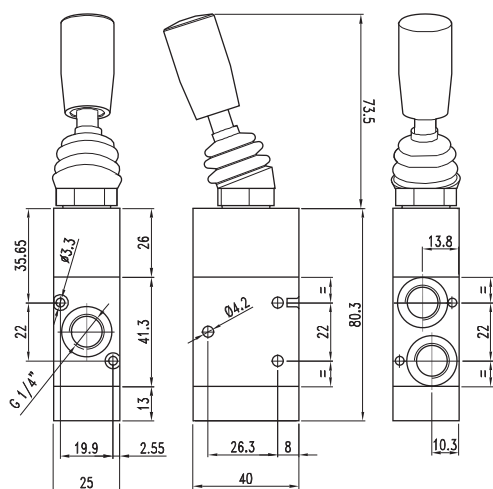
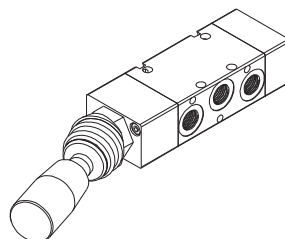
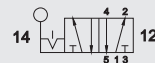

1/4 - 3/2 NC - LEVA IN TESTA BISTABILE
1/4 - 3/2 NC - TOP LEVER, BISTABLE

CODE: VM4010103302

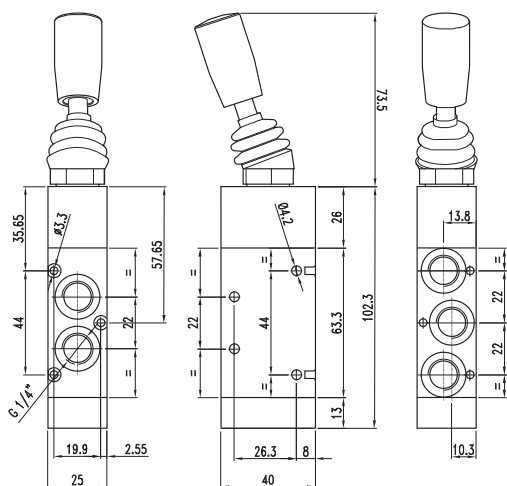
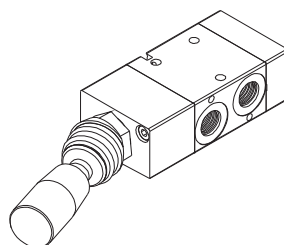

1/4 - 5/2 LEVA IN TESTA, BISTABILE
1/4 - 5/2 TOP LEVER, BISTABLE

CODE: VM4010105302

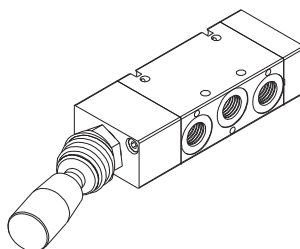

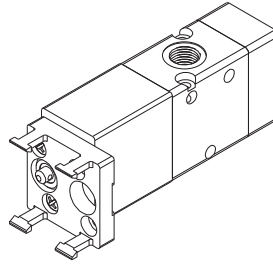
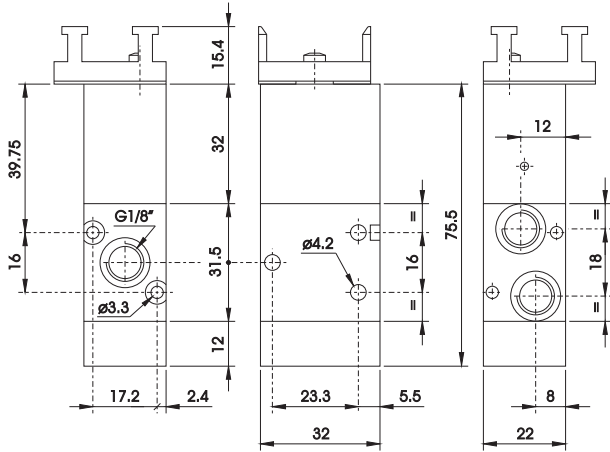

1/8 - 3/2 NC - ADATTATORE IN TESTA
1/8 - 3/2 NC - ADAPTOR IN TOP

CODE: VM401 2023201

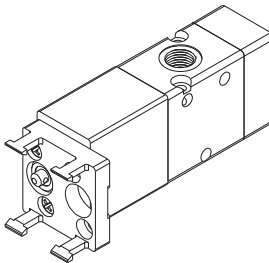
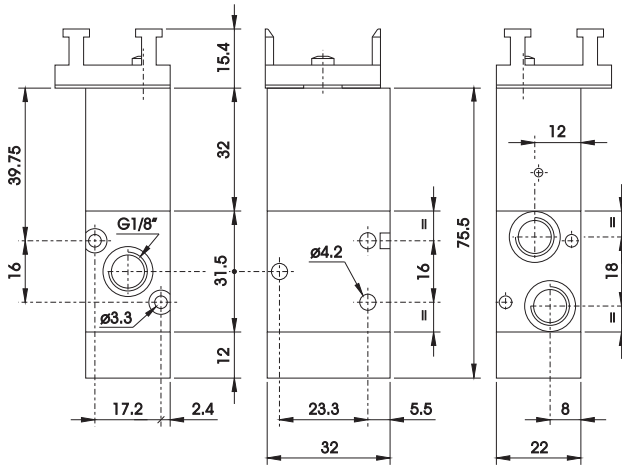
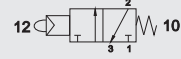

1/8 - 3/2 NA - ADATTATORE IN TESTA
1/8 - 3/2 NO - ADAPTOR IN TOP

CODE: VM401 1023201

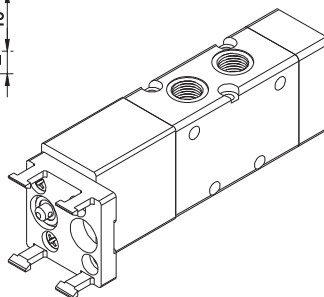
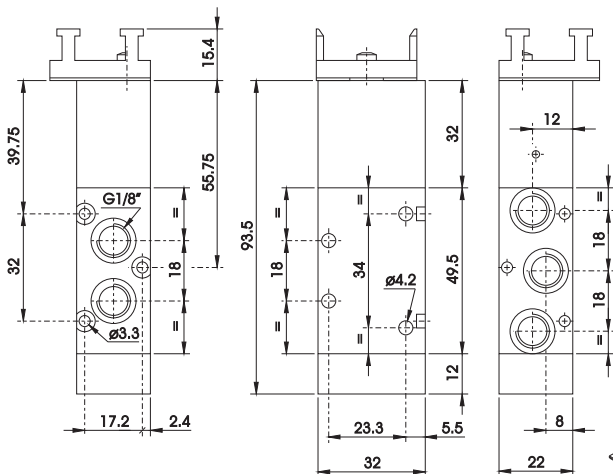
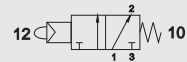

1/8 - 5/2 ADATTATORE IN TESTA
1/8 - 5/2 ADAPTOR IN TOP

CODE: VM401 0025201

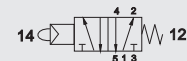

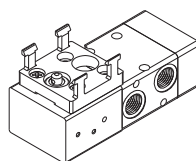
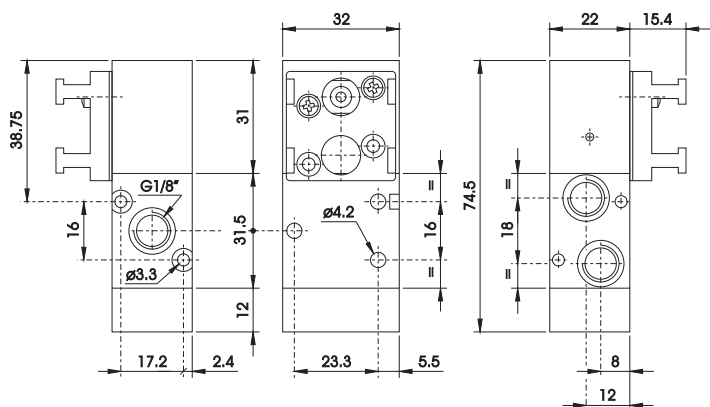

1/8 - 3/2 NC - ADATTATORE A 90°
1/8 - 3/2 NC - 90° ADAPTOR

CODE: VM4012193201

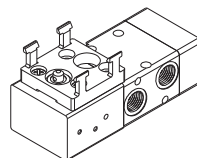
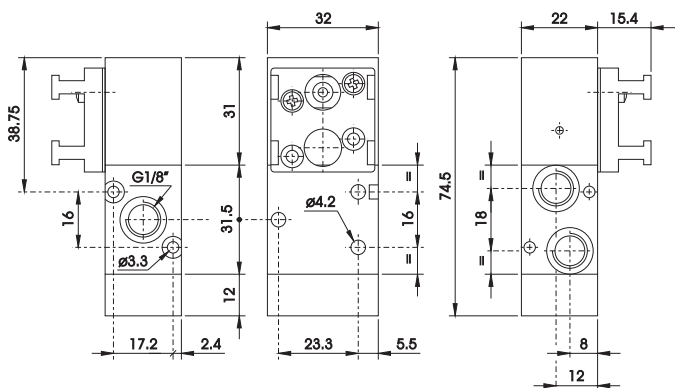
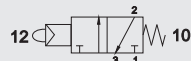

1/8 - 3/2 NA - ADATTATORE A 90°
1/8 - 3/2 NO - 90° ADAPTOR

CODE: VM4011193201

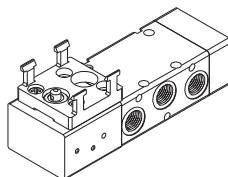
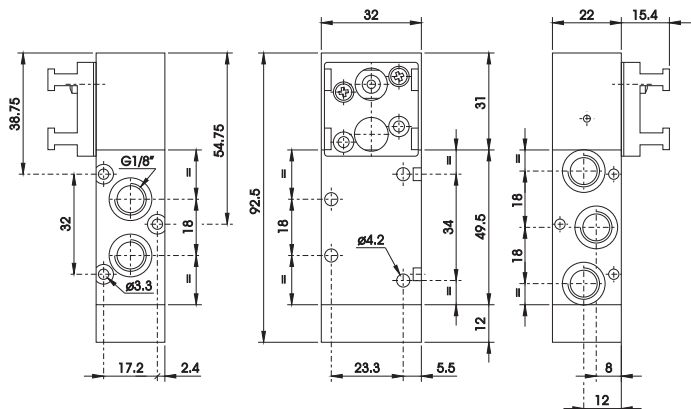
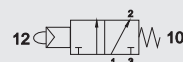

1/8 - 5/2 ADATTATORE A 90°
1/8 - 5/2 90° ADAPTOR

CODE: VM4010195201

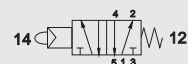

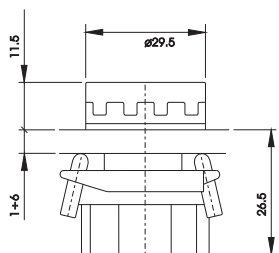

PULSANTE PROTETTO
PROTECTED PUSH BUTTON

CODE: AP401

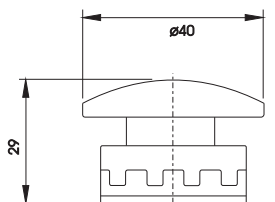

FUNGO Ø40
Ø40 MUSHROOM

CODE: AP402
CODE: AP402A

MONOSTABILE / MONOSTABLE
SBLOCCO A ROTAZIONE / TURN TO UNLOCK

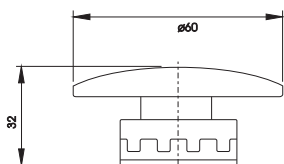

FUNGO Ø60
Ø60 PALM

CODE: AP403
CODE: AP403A

MONOSTABILE / MONOSTABLE
SBLOCCO A ROTAZIONE / TURN TO UNLOCK

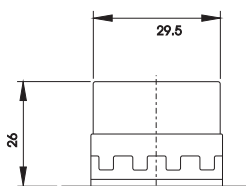

SELETORE LEVA CORTA
SHORT LEVER SELECTOR

CODE: AP404
CODE: AP404A

MONOSTABILE / MONOSTABLE
BISTABILE / BISTABLE

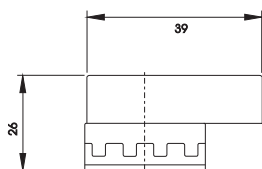

SELETORE LEVA LUNGA
LONG LEVER SELECTOR

CODE: AP405
CODE: AP405A

MONOSTABILE / MONOSTABLE
BISTABILE / BISTABLE

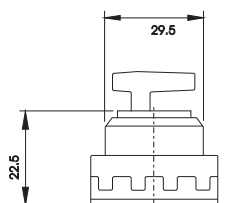

SELETORE A CHIAVE
KEY SELECTOR

CODE: AP406

BISTABILE / BISTABLE

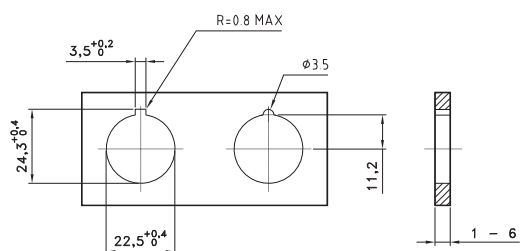

FORO PER MONTAGGIO A PANNELLO
PANEL MOUNTING HOLE



Valvole ad azionamento meccanico con costruzione interamente in alluminio per garantire robustezza e durata nel tempo.
Disponibili della taglia 1/8 e nelle funzioni 3/2 e 5/2.

Mechanical operated Valves , entirely in aluminium to ensure strength and durability.
Available size is 1/8 and available functions are 3/2 and 5/2.

DATI TECNICI / TECHNICAL DATA

Fluido / Fluid	Aria con o senza lubrificazione / Lubricated or non lubricated air
Temperatura di esercizio / Operating temperature range	Max +60C°
Pressione massima di esercizio / Max operating pressure	10 bar
Diametro nominale / Nominal orifice	1/8: 5 mm
Portata a 6 bar / Flow rates 6bar	1/8=550 NI/min.

SELEZIONE RAPIDA / FAST SELECT

	PUNTALE, RITORNO A MOLLA TAPPET, SPRING RETURN VM4012013201 3/2 1/8 NC		LEVA RULLO SERVOPILOTATA, RITORNO A MOLLA SERVO-PILOTED ROLLER LEVER, SPRING RETURN VM4012183201 3/2 1/8 NC
	PUNTALE, RITORNO A MOLLA TAPPET, SPRING RETURN VM4010015201 5/2 1/8		LEVA RULLO SERVOPILOTATA, RITORNO A MOLLA SERVO-PILOTED ROLLER LEVER, SPRING RETURN VM4010185201 5/2 1/8
	PUNTALE SERVOPILOTATO RITORNO A MOLLA SERVO-PILOTED TAPPET, SPRING RETURN VM4012113201 3/2 1/8 NC		LEVA UNIDIREZIONALE, RITORNO A MOLLA UNI-DIRECTIONAL LEVER, SPRING RETURN VM4012043201 3/2 1/8 NC
	PUNTALE SERVOPILOTATO, RITORNO A MOLLA SERVO-PILOTED TAPPET, SPRING RETURN VM4010115201 5/2 1/8		LEVA UNIDIREZIONALE, RITORNO A MOLLA UNI-DIRECTIONAL LEVER, SPRING RETURN VM4010045201 5/2 1/8
	LEVA RULLO, RITORNO A MOLLA ROLLER LEVER, SPRING RETURN VM4012033201 3/2 1/8 NC		
	LEVA RULLO, RITORNO A MOLLA ROLLER LEVER, SPRING RETURN VM4010035201 5/2 1/8		

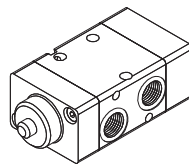
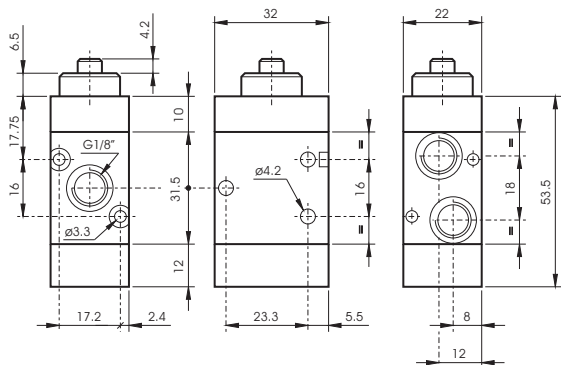

1/8 - 3/2 NC - PUNTALE - RITORNO A MOLLA
1/8 - 3/2 NC - TAPPET - SPRING RETURN

CODE: VM4010013201

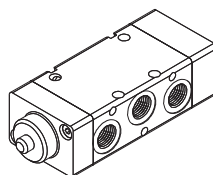
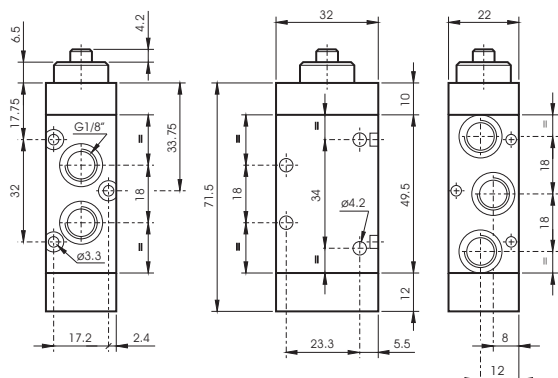
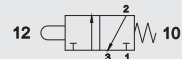

1/8 - 5/2 PUNTALE - RITORNO A MOLLA
1/8 - 5/2 TAPPET - SPRING RETURN

CODE: VM4010015201

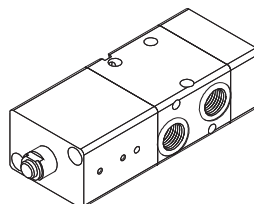
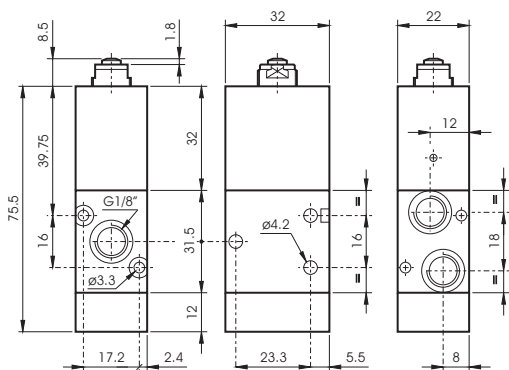

1/8 - 3/2 NC - PUNTALE SERVOPILOTATO -
RITORNO A MOLLA
1/8 - 3/2 NC - SERVOPILOTED TAPPET -
SPRING RETURN

CODE: VM4010113201

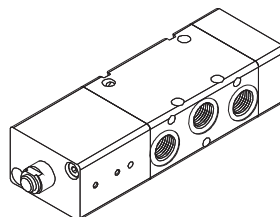
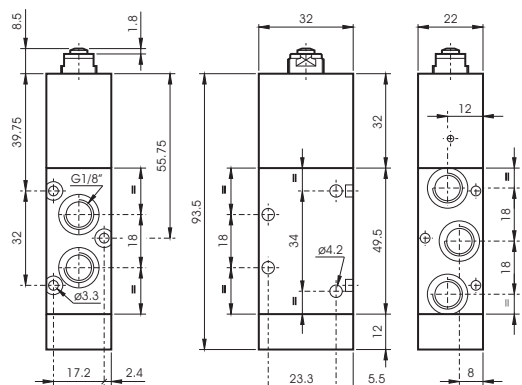
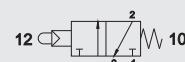

1/8 - 5/2 PUNTALE SERVOPILOTATO -
RITORNO A MOLLA
1/8 - 5/2 SERVO-PILOTED TAPPET -
SPRING RETURN

CODE: VM4010115201

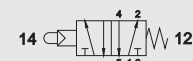

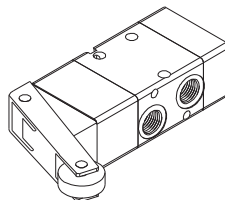
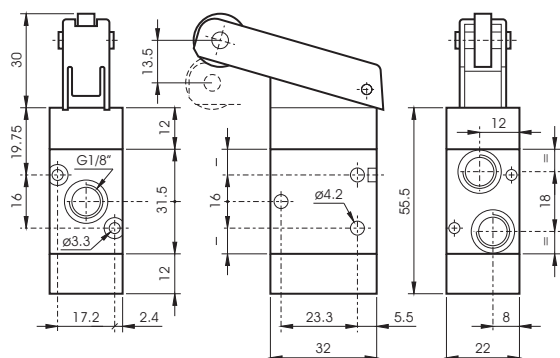

1/8 - 3/2 NC - LEVA RULLO - RITORNO A MOLLA
1/8 - 3/2 NC - ROLLER LEVER - SPRING
RETURN

CODE: VM4010033201

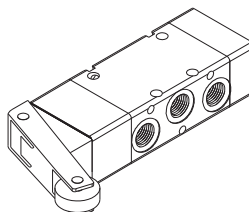
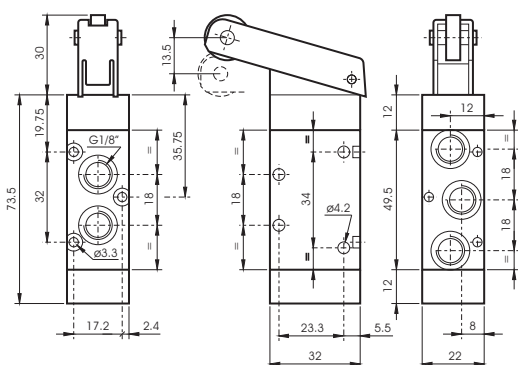
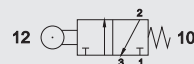

1/8 - 5/2 LEVA RULLO - RITORNO A MOLLA
1/8 - 5/2 ROLLER LEVER - SPRING RETURN

CODE: VM4010035201

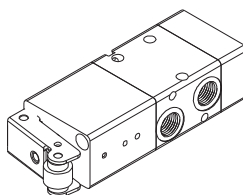
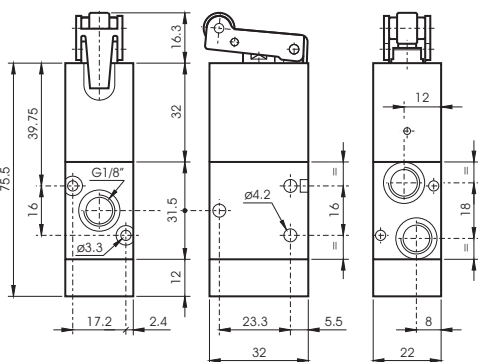
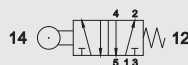

1/8 - 3/2 NC - LEVA RULLO SERVOPILOTATO -
RITORNO A MOLLA
1/8 - 3/2 NC SERVO-PILOTED ROLLER LEVER -
SPRING RETURN

CODE: VM4010183201

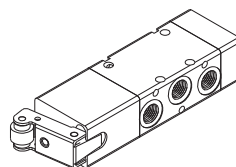
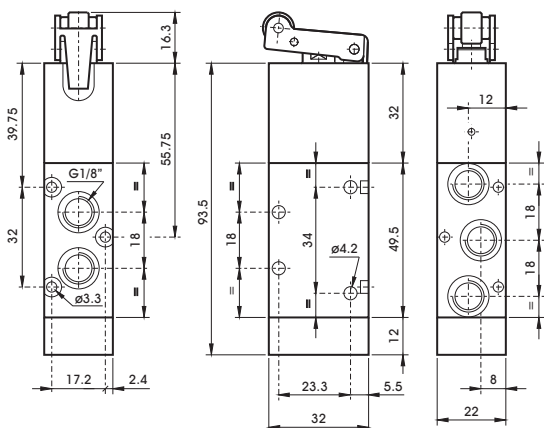
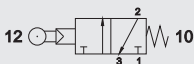

1/8 - 5/2 ROLLER LEVER SERVOPILOTATO -
RITORNO A MOLLA
1/8 - 5/2 SERVO-PILOTED ROLLER LEVER -
SPRING RETURN

CODE: VM4010185201



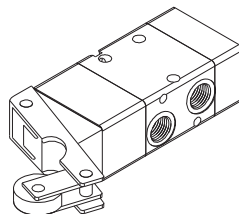
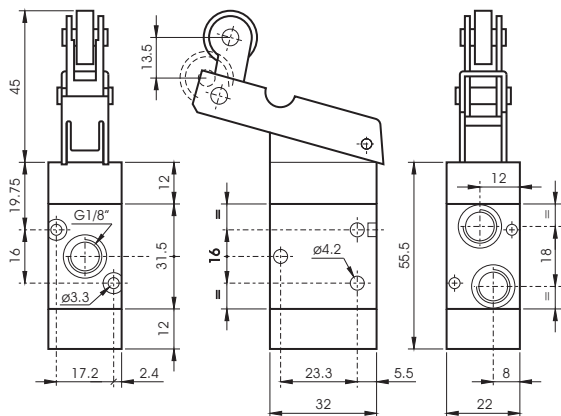

1/8 - 3/2 NC - LEVA UNIDIREZIONALE -
RITORNO A MOLLA
1/8 - 3/2 NC - UNI-DIRECTIONAL LEVER -
SPRING RETURN

CODE: VM4010043201

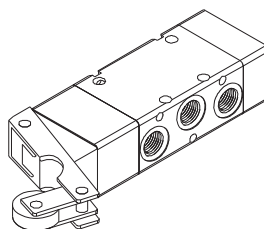
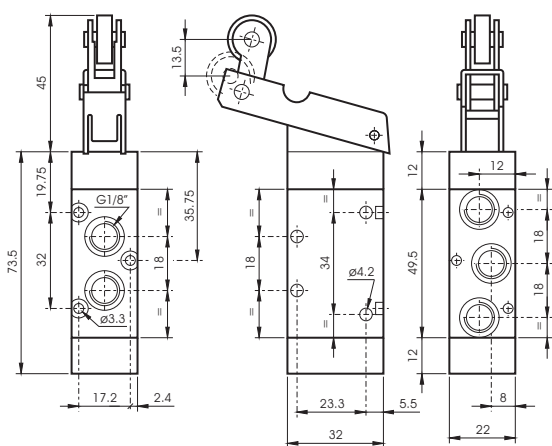
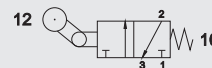

1/8 - 5/2 LEVA UNIDIREZIONALE -
RITORNO A MOLLA
1/8 - 5/2 UNI-DIRECTIONAL LEVER -
SPRING RETURN

CODE: VM4010045201

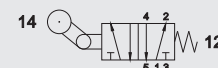

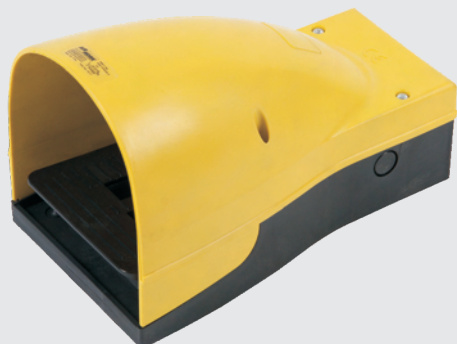

La serie di valvole a pedale, vengono proposte con: protezione o senza protezione, con fermo di sicurezza o senza e nelle funzioni 3/2 e 5/2. L'ampia base d'appoggio, garantisce stabilità durante l'utilizzo.

The pedal valves are available with protection or without protection, with or without lock. Available functions are 3/2 and 5/2. The large base ensures stability during the use.

DATI TECNICI / TECHNICAL DATA

Fluido / Fluid	Aria con o senza lubrificazione / Lubricated or non lubricated air
Temperatura di esercizio / Operating temperature range	Max +60C°
Pressione massima di esercizio / Max operating pressure	10 bar
Diametro nominale / Nominal orifice	1/4: 7,5mm

COMPONENTI / COMPONENTS

Protezione / Protection cover	Plastica / Plastic
Corpo / Body	Alluminio / Aluminium
Spola / Spool	Alluminio nichelato / Nickel plated aluminium
Guarnizioni / Seals	NBR
Molla / Spring	Inox / Steel

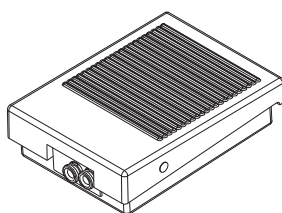
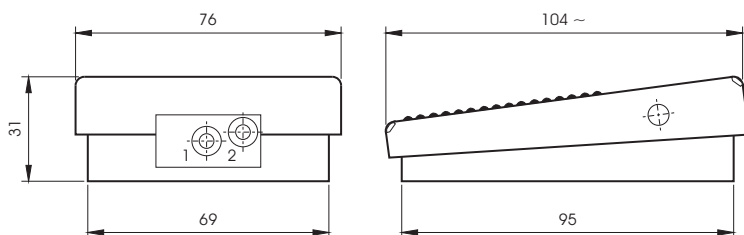

VALVOLA A PEDALE 3/2 NC TUBO 4
PEDAL VALVE 3/2 NC TUBE D.4

CODE: VP40200301

MONOSTABILE
MONO-STABLE

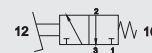

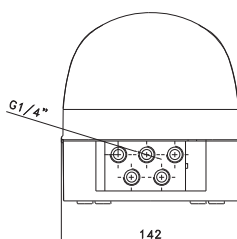
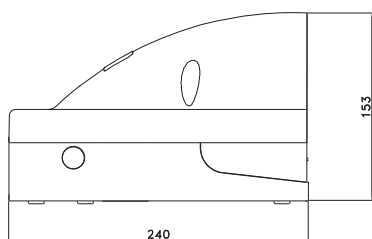

VALVOLA A PEDALE CON PROTEZIONE 1/4 5/2
PEDAL VALVE WITH PROTECTION COVER 1/4 5/2

CODE: VP40010531 MONOSTABILE
MONO-STABLE

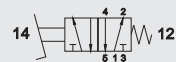

CODE: VP40011531 CON FERMO SICUREZZA
WITH SAFETY FEATURE



CODE: VP40010532 BISTABILE
BI-STABLE

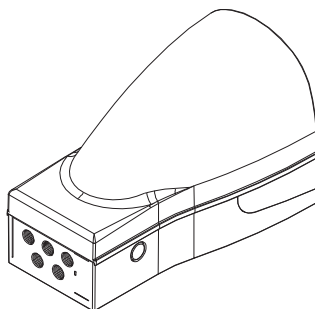
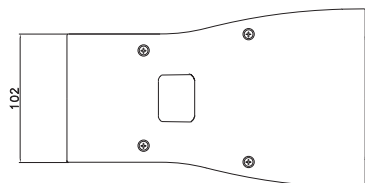

VALVOLA A PEDALE SENZA PROTEZIONE 1/4 5/2
PEDAL VALVE WITHOUT PROTECTION COVER 1/4 5/2

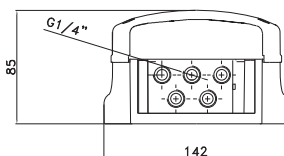
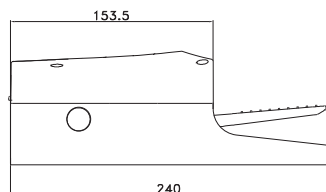

CODE: VP40000531 MONOSTABILE
MONO-STABLE



CODE: VP40000532 BISTABILE
BI-STABLE

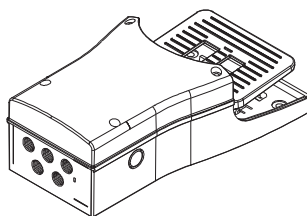
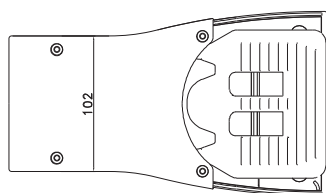



Il regolatore di flusso in linea ha la funzione di regolare la velocità di spostamento dei cilindri pneumatici e possono essere di due tipi:
Unidirezionali: significa che la regolazione del flusso dell'aria avviene solo in un senso.
Bidirezionale: la regolazione avviene nei due sensi.
I regolatori si possono montare a pannello.

The flow regulator in line has the function to regulate the speed of the pneumatic cylinders and they can be:

One-way: the regulation is in one way

Two-way: the regulation is in two ways

The flow-regulator can be mounted on the panel/board

DATI TECNICI / TECHNICAL DATA

Fluido / Fluid	aria con o senza lubrificazione / lubricated or non lubricated air
Pressione di esercizio / Pressure range	2 - 10bar
Temperatura di esercizio / Temperature range	-10 c° - +80c°
Portata a 6 bar / Nominal flow rate at 6 bar	Unidirezionale / Uni-directional: M5=130 NI/min - 1/8=450 NI/min - 1/4=600 NI/min - 3/8=1100 NI/min - 1/2=1400 NI/min Bidirezionale / Bi-directional: M5=60 NI/min - 1/8=210 NI/min - 1/4=300 NI/min - 3/8=500 NI/min - 1/2=500 NI/min

COMPONENTI / COMPONENTS

Corpo / Body	Alluminio / Aluminium
Parti interne / Internal parts	Ottone OT58 / Brass OT58
Guarnizione / Seal	NBR

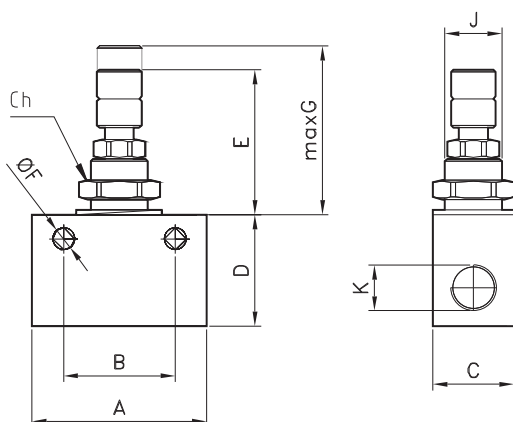

BIDIREZIONALE
BI-DIRECTIONAL

CODE	K
RF4005100	M5
RF4005200	1/8
RF4005300	1/4
RF4005400	3/8
RF4005500	1/2



UNIDIREZIONALE
UNI-DIRECTIONAL

CODE	K
RF4004100	M5
RF4004200	1/8
RF4004300	1/4
RF4004400	3/8
RF4004500	1/2

K	A	B	C	D	E	F	G	Ch	J
M5	25	18	12	20	23	4.5	28	12	10X1
1/8	35	24	15	22	24	4.5	29.5	12	10X1
1/4	40	24	20	30	26	4.5	32.5	12	10X1
3/8	45	30	22	35	31	6	39.5	18	15X1
1/2	57	30	27	40	31	6	39.5	18	15X1



Il regolatore di flusso ha la funzione di regolare la velocità di spostamento dei cilindri pneumatici e possono essere di due tipi:
Unidirezionali: significa che la regolazione del flusso dell'aria avviene solo in un senso.
Bidirezionale: la regolazione avviene nei due sensi.
Vi sono modelli adatti al montaggio su cilindri o sulle valvole, e la regolazione può essere fatta manualmente o con cacciavite.

The flow regulator has the function to regulate the speed of the pneumatic cylinders and they can be:
uni-directional: the regulation is in one way
bi-directional: the regulation is in two ways.
There are models suitable for mounting on cylinders or on valves, and the adjustment can be done manually or with a screwdriver.

DATI TECNICI / TECHNICAL DATA

Tipo / Type	Serie NSC	Serie A
Fluido / Fluid	Aria / air	Aria / air
Temperatura di esercizio / Temperature range	0° +60°C	0° +80°C
Pressione / Pressure	max. 10 bar	max. 10 bar

COMPONENTI / COMPONENTS

SERIE NSC

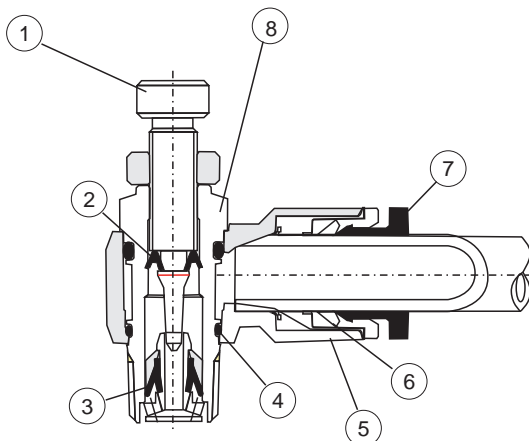

1 ghiera / needle	ottone / brass
2 guarnizione / seal	NBR
3 guarnizione / seal	NBR
4 o-ring	NBR
5 corpo / body	PBT
6 pinza / lock claw	SUS 304
7 anello / ring	POM
11 corpo / body	ottone / brass

SERIE A

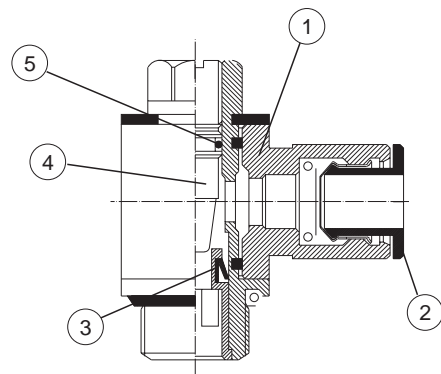

1 corpo / body	ottone / brass
2 anello / ring	ottone / brass
3 guarnizione / seal	NBR
4 vite / screw	ottone / brass
5 o-ring	NBR

NSC-C

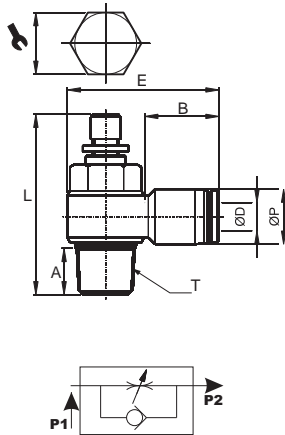

REGOLATORE DI FLUSSO CONICO PER CILINDRI
FLOW REGULATOR FOR CYLINDER TAPER

CODE	ØD	T	ØP	L(max)	E	A	B		
NSC-C 0401B	4	R1/8	10,5	40,1	30,5	8	16,3	11	50
NSC-C 0402B	4	R1/4	10,5	45,7	34,5	10	16,3	15	50
NSC-C 0601B	6	R1/8	12,5	40,1	31,5	8	17,6	11	50
NSC-C 0602B	6	R1/4	12,5	45,7	35,0	10	17,6	15	50
NSC-C 0603B	6	R3/8	12,5	55,0	38,7	11	17,6	19	25
NSC-C 0801B	8	R1/8	14,5	40,1	33,0	8	18,7	11	50
NSC-C 0802B	8	R1/4	14,5	45,7	36,8	10	18,7	15	50
NSC-C 0803B	8	R3/8	14,5	55,0	40,1	11	18,7	19	25
NSC-C 0804B	8	R1/2	14,5	60,2	45,8	14	18,7	24	20
NSC-C 1002B	10	R1/4	17,5	45,7	38,8	10	19,6	15	25
NSC-C 1003B	10	R3/8	17,5	55,0	42,2	11	19,6	19	25
NSC-C 1004B	10	R1/2	17,5	60,2	47,5	14	19,6	24	20
NSC-C 1202B	12	R1/4	20,5	45,7	40,8	10	21,9	15	25
NSC-C 1203B	12	R3/8	20,5	55,0	45,9	11	21,9	19	25
NSC-C 1204B	12	R1/2	20,5	60,2	50,1	14	21,9	24	20

NSC-GC

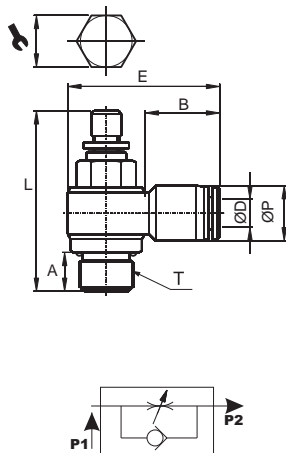

REGOLATORE DI FLUSSO CILINDRICO PER CILINDRI
FLOW REGULATOR FOR CYLINDER PARALLEL

CODE	ØD	T	ØP	L(max)	E	A	B		
NSC-GC 04M5B	4	M5	10,5	30,2	25,1	3,6	16,3	8	50
NSC-GC 0401B	4	G1/8	10,5	40,1	35,5	6,0	16,3	8	50
NSC-GC 0402B	4	G1/4	10,5	45,7	34,5	8,0	16,3	12	50
NSC-GC 06M5B	6	M5	12,5	30,2	27,8	3,6	17,6	8	50
NSC-GC 0601B	6	G1/8	12,5	40,1	31,2	6,0	17,6	8	50
NSC-GC 0602B	6	G1/4	12,5	45,7	35,0	8,0	17,6	12	50
NSC-GC 0603B	6	G3/8	12,5	55,0	38,7	8,0	17,6	14	25
NSC-GC 0801B	8	G1/8	14,5	40,1	33,0	6,0	18,7	8	50
NSC-GC 0802B	8	G1/4	14,5	45,7	36,5	8,0	18,7	12	50
NSC-GC 0803B	8	G3/8	14,5	55,0	40,1	8,0	18,7	14	25
NSC-GC 0804B	8	G1/2	14,5	60,2	45,8	9,0	18,7	19	20
NSC-GC 1002B	10	G1/4	17,5	45,7	38,8	8,0	19,6	12	25
NSC-GC 1003B	10	G3/8	17,5	55,0	42,2	8,0	19,6	14	25
NSC-GC 1004B	10	G1/2	17,5	60,2	47,5	9,0	19,6	19	20
NSC-GC 1202B	12	G1/4	20,5	45,7	40,8	8,0	21,9	12	25
NSC-GC 1203B	12	G3/8	20,5	55,0	45,9	8,0	21,9	14	25
NSC-GC 1204B	12	G1/2	20,5	60,2	50,1	9,0	21,9	19	20

NSC-V

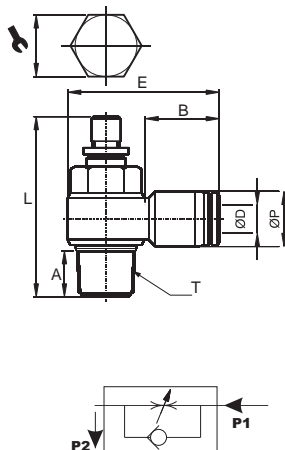

REGOLATORE DI FLUSSO CONICO PER VALVOLA
FLOW REGULATOR FOR VALVES TAPER

CODE	ØD	T	ØP	L(max)	E	A	B		
NSC-V 0401R	4	R1/8	10,5	40,1	30,5	8	16,3	11	50
NSC-V 0402R	4	R1/4	10,5	45,7	34,5	10	16,3	15	50
NSC-V 0601R	6	R1/8	12,5	40,1	31,2	8	17,6	11	50
NSC-V 0602R	6	R1/4	12,5	45,7	35,0	10	17,6	15	50
NSC-V 0603R	6	R3/8	12,5	55,0	38,7	11	17,6	19	25
NSC-V 0801R	8	R1/8	14,5	40,1	33,0	8	18,7	11	50
NSC-V 0802R	8	R1/4	14,5	45,7	36,8	10	18,7	15	50
NSC-V 0803R	8	R3/8	14,5	55,0	40,1	11	18,7	19	25
NSC-V 0804R	8	R1/2	14,5	60,2	45,8	14	18,7	24	20
NSC-V 1002R	10	R1/4	17,5	45,7	38,8	10	19,6	15	25
NSC-V 1003R	10	R3/8	17,5	55,0	42,2	11	19,6	19	25
NSC-V 1004R	10	R1/2	17,5	60,2	47,5	14	19,6	24	20
NSC-V 1202R	12	R1/4	20,5	45,7	40,8	10	21,9	15	25
NSC-V 1203R	12	R3/8	20,5	55,0	45,9	11	21,9	19	25
NSC-V 1204R	12	R1/2	20,5	60,2	50,1	14	21,9	24	20

NSC-GV

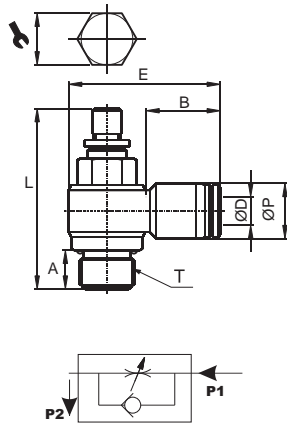

REGOLATORE DI FLUSSO CILINDRICO PER VALVOLE
FLOW REGULATOR FOR VALVES PARALLEL

CODE	ØD	T	ØP	L(MAX)	E	A	B		
NSC-GV 04M5R	4	M5	10,5	30,2	25,1	3,6	16,3	8	50
NSC-GV 0401R	4	G1/8	10,5	40,1	30,5	6,0	16,3	8	50
NSC-GV 0402R	4	G1/4	10,5	45,7	34,5	8,0	16,3	12	50
NSC-GV 06M5R	6	M5	12,2	30,2	27,8	3,6	17,6	8	50
NSC-GV 0601R	6	G1/8	12,5	40,1	31,2	6,0	17,6	8	50
NSC-GV 0602R	6	G1/4	12,5	45,7	35,0	8,0	17,6	12	50
NSC-GV 0603R	6	G3/8	12,5	55,0	38,7	8,0	17,6	14	25
NSC-GV 0801R	8	G1/8	14,5	40,1	33,0	6,0	18,7	8	50
NSC-GV 0802R	8	G1/4	14,5	45,7	36,8	8,0	18,7	12	50
NSC-GV 0803R	8	G3/8	14,5	55,0	40,1	8,0	18,7	14	25
NSC-GV 0804R	8	G1/2	14,5	60,2	45,8	9,0	18,7	19	20
NSC-GV 1002R	10	G1/4	17,5	45,7	38,8	8,0	19,6	12	25
NSC-GV 1003R	10	G3/8	17,5	55,0	42,2	8,0	19,6	14	25
NSC-GV 1004R	10	G1/2	17,5	60,2	47,5	9,0	19,6	19	20
NSC-GV 1202R	12	G1/4	20,5	45,7	40,8	8,0	21,6	12	25
NSC-GV 1203R	12	G3/8	20,5	55,0	45,9	8,0	21,6	14	25
NSC-GV 1204R	12	G1/2	20,5	60,2	50,1	9,0	21,6	19	20

A131

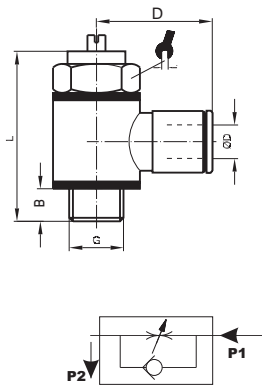

REGOLATORE DI FLUSSO CILINDRICO PER VALVOLE
FLOW REGULATOR FOR VALVES PARALLEL

CODE	ØD	G	B	D	L	NI/min*		
A131 4-M5	4	M5	6,0	17,0	24,5	45	8	50
A131 4-1/8	4	G1/8	5,5	21,0	31,5	310	14	50
A131 5-1/8	5	G1/8	5,5	22,5	31,5	310	14	50
A131 6-M5	6	M5	4,0	21,0	24,5	45	8	50
A131 6-1/8	6	G1/8	5,5	22,5	31,5	390	14	50
A131 6-1/4	6	G1/4	6,0	24,0	38,0	710	17	50
A131 8-1/8	8	G1/8	5,5	24,5	31,5	390	14	25
A131 8-1/4	8	G1/4	6,0	26,0	38,0	810	17	25
A131 8-3/8	8	G3/8	6,0	28,0	40,0	1050	20	25
A131 10-1/4	10	G1/4	6,0	28,0	38,0	810	17	25
A131 10-3/8	10	G3/8	6,0	29,0	47,0	1050	20	25
A131 12-1/4	12	G1/4	6,0	28,0	38,0	810	17	25
A131 12-3/8	12	G3/8	6,0	30,0	47,0	1050	20	10

A132

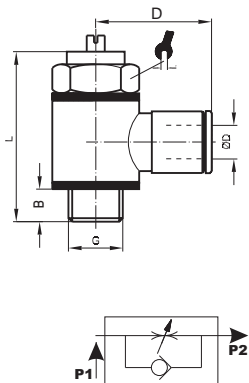

REGOLATORE DI FLUSSO CILINDRICO PER CILINDRI
FLOW REGULATOR FOR CYLINDER PARALLEL

CODE	ØD	G	B	D	L	NI/min*		
A132 4-M5	4	M5	6,0	17,0	24,5	45	8	50
A132 4-1/8	4	G1/8	5,5	21,0	31,5	310	14	50
A132 5-1/8	5	G1/8	5,5	22,5	31,5	310	14	50
A132 6-M5	6	M5	4,0	21,0	24,5	45	8	50
A132 6-1/8	6	G1/8	5,5	22,5	31,5	390	14	50
A132 6-1/4	6	G1/4	6,0	24,0	38,0	710	17	50
A132 8-1/8	8	G1/8	5,5	24,5	31,5	390	14	25
A132 8-1/4	8	G1/4	6,0	26,0	38,0	710	17	25
A132 8-3/8	8	G3/8	6,0	28,0	40,0	1050	20	25
A132 10-1/4	10	G1/4	6,0	28,0	38,0	810	17	25
A132 10-3/8	10	G3/8	6,0	29,0	47,0	1050	20	25
A132 12-1/4	12	G1/4	6,0	28,0	38,0	810	17	25
A132 12-3/8	12	G3/8	6,0	30,0	47,0	1050	20	10

A133

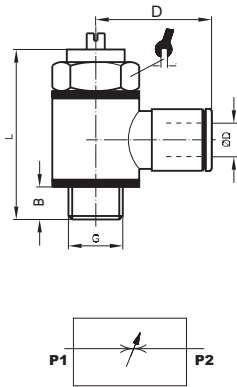

REGOLATORE DI FLUSSO CILINDRICO BIDIREZIONALE
BIDIRECTIONAL PARALLEL FLOW REGULATOR

CODE	ØD	G	B	D	L	NI/min*		
A133 4-M5	4	M5	6,0	17,0	24,5	45	8	50
A133 4-1/8	4	G1/8	5,5	21,0	31,5	310	14	50
A133 5-1/8	5	G1/8	5,5	22,5	31,5	310	14	50
A133 6-M5	6	M5	4,0	21,0	24,5	45	8	50
A133 6-1/8	6	G1/8	5,5	22,5	31,5	390	14	50
A133 6-1/4	6	G1/4	6,0	24,0	38,0	710	17	50
A133 8-1/8	8	G1/8	5,5	24,5	31,5	390	14	25
A133 8-1/4	8	G1/4	6,0	26,0	38,0	810	17	25
A133 8-3/8	8	G3/8	6,0	28,0	40,0	1050	20	25
A133 10-1/4	10	G1/4	6,0	28,0	38,0	810	17	25

A129

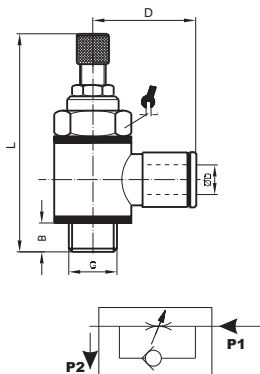

REGOLATORE DI FLUSSO CILINDRICO MANUALE PER VALVOLE
MANUAL FLOW REGULATOR PARALLEL FOR VALVES

CODE	ØD	G	B	D	L	NI/min*		
A129 4-1/8	4	G1/8	5,5	17,0	49,0	310	14	50
A129 6-1/8	6	G1/8	5,5	21,0	49,0	390	14	50
A129 8-1/8	8	G1/8	5,5	22,5	49,0	390	14	50
A129 6-1/4	6	G1/4	6,0	22,5	56,5	710	17	25
A129 8-1/4	8	G1/4	6,0	24,0	56,5	810	17	25
A129 10-1/4	10	G1/4	6,0	24,5	56,5	810	17	25
A129 12-1/4	12	G1/4	6,0	26,0	56,5	810	17	25

A130

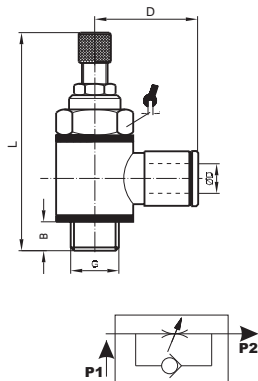

REGOLATORE DI FLUSSO CILINDRICO MANUALE PER CILINDRI
MANUAL FLOW REGULATOR PARALLEL FOR CYLINDER

CODE	ØD	G	B	D	L	NI/min*		
A130 4-1/8	4	G1/8	5,5	17,0	49,0	310	14	50
A130 6-1/8	6	G1/8	5,5	21,0	49,0	390	14	50
A130 8-1/8	8	G1/8	5,5	22,5	49,0	390	14	50
A130 6-1/4	6	G1/4	6,0	22,5	56,5	710	17	25
A130 8-1/4	8	G1/4	6,0	24,0	56,5	810	17	25
A130 10-1/4	10	G1/4	6,0	24,5	56,5	810	17	25
A130 12-1/4	12	G1/4	6,0	26,0	56,5	810	17	25

A138

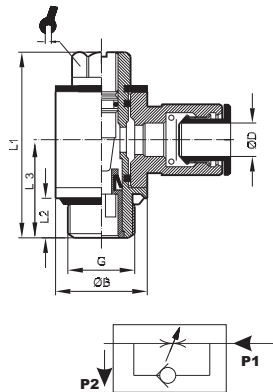

REGOLATORE DI FLUSSO CILINDRICO GIREVOLE PER VALVOLE
SWIVEL FLOW REGULATOR PARALLEL FOR VALVES

CODE	ØD	G	ØB	L1	L2	L3	NL/min*		
A138 4-1/8	4	G1/8	14	32	6	15,0	310	9	10
A138 6-1/8	6	G1/8	14	32	6	15,0	390	9	10
A138 6-1/4	6	G1/4	18	37	8	17,5	710	12	10
A138 8-1/8	8	G1/8	14	32	6	15,0	390	9	10
A138 8-1/4	8	G1/4	18	37	8	17,5	810	12	10
A138 10-1/4	10	G1/4	18	37	8	17,5	810	12	10
A138 12-1/4	12	G1/4	18	37	8	17,5	810	12	10

A139

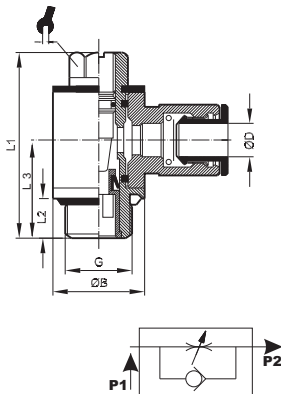

REGOLATORE DI FLUSSO CILINDRICO GIREVOLE PER CILINDRI
SWIVEL FLOW REGULATOR PARALLEL FOR CYLINDER

CODE	ØD	G	ØB	L1	L2	L3	NL/min*		
A139 4-1/8	4	G1/8	14	32	6	15,0	310	9	10
A139 6-1/8	6	G1/8	14	32	6	15,0	390	9	10
A139 6-1/4	6	G1/4	18	37	8	17,5	710	12	10
A139 8-1/8	8	G1/8	14	32	6	15,0	390	9	10
A139 8-1/4	8	G1/4	18	37	8	17,5	810	12	10
A139 10-1/4	10	G1/4	18	37	8	17,5	810	12	10
A139 12-1/4	12	G1/4	18	37	8	17,5	810	12	10

A156

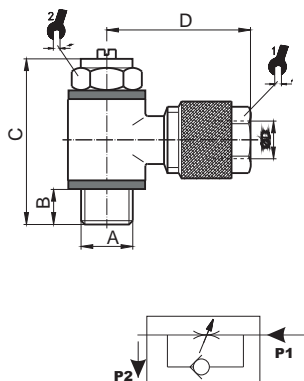

REGOLATORE DI FLUSSO CILINDRICO A CALZAMENTO PER VALVOLE
FLOW REGULATOR PARALLEL FOR VALVES PUSH-ON

CODE	Ø	A	B	C	D	NL/min*			
A156 5/3-M5	5/3	M5	4,0	24,5	15,0	45	8	8	25
A156 5/3-1/8	5/3	G1/8	5,5	31,5	23,0	310	8	14	25
A156 6/4-M5	6/4	M5	4,0	24,5	15,0	45	9	8	25
A156 6/4-1/8	6/4	G1/8	5,5	31,5	23,0	310	10	14	25
A156 6/4-1/4	6/4	G1/4	6,0	38,0	26,0	420	10	17	25
A156 8/6-1/8	8/6	G1/8	5,5	31,5	23,0	310	12	14	25
A156 8/6-1/4	8/6	G1/4	6,0	38,0	26,0	420	12	17	25

A157

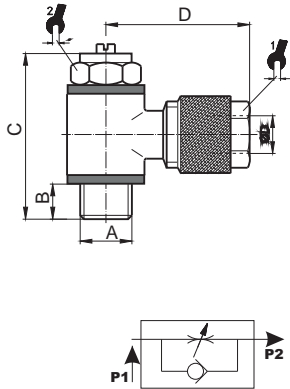

REGOLATORE DI FLUSSO CILINDRICO A CALZAMENTO PER CILINDRI
FLOW REGULATOR PARALLEL FOR CYLINDER PUSH-ON

CODE	Ø	A	B	C	D	NI/min*			
A157 5/3-M5	5/3	M5	4,0	24,5	15,0	45	8	8	25
A157 5/3-1/8	5/3	G1/8	5,5	34,0	23,0	310	8	14	25
A157 6/4-M5	6/4	M5	4,0	24,5	15,0	45	9	8	25
A157 6/4-1/8	6/4	G1/8	5,5	31,5	23,0	310	10	14	25
A157 6/4-1/4	6/4	G1/4	6,0	38,0	26,0	420	10	17	25
A157 8/6-1/8	8/6	G1/8	5,5	31,5	23,0	310	12	14	25
A157 8/6-1/4	8/6	G1/4	6,0	38,0	26,0	420	12	17	25
A157 8/6-3/8	8/6	G3/8	7,0	47,0	26,0	500	12	20	25

A158

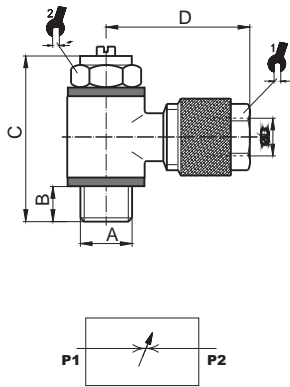

REGOLATORE DI FLUSSO CILINDRICO A CALZAMENTO BIDIREZIONALE
FLOW REGULATOR PARALLEL BIDIRECTIONAL PUSH-ON

CODE	Ø	A	B	C	D	NI/min*			
A158 5/3-M5	5/3	M5	4,0	24,5	15,0	45	8	8	25
A158 6/4-M5	6/4	M5	4,0	24,5	15,0	45	9	8	25
A158 6/4-1/8	6/4	G1/8	5,5	31,5	23,0	310	10	14	25
A158 6/4-1/4	6/4	G1/4	6,0	38,0	26,0	420	10	17	25
A158 8/6-1/8	8/6	G1/8	5,5	31,5	23,0	310	12	14	25
A158 8/6-1/4	8/6	G1/4	6,0	38,0	26,0	420	12	17	25

A159

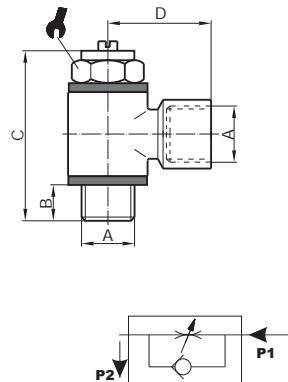

REGOLATORE DI FLUSSO CILINDRICO PER VALVOLE FEMMINA
FLOW REGULATOR PARALLEL FOR VALVES FEMALE THREAD

CODE	A	B	C	D	NI/min*		
A159 M5	M5	3,5	24,5	10,5	45	8	50
A159 1/8	G1/8	4,5	31,5	16,0	310	14	50
A159 1/4	G1/4	6,5	38,0	22,0	450	17	50
A159 3/8	G3/8	8,5	47,0	22,0	1040	20	25
A159 1/2	G1/2	10,0	55,0	32,0	2200	26	10

A160

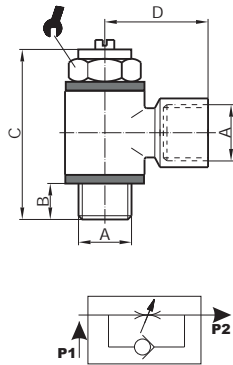

REGOLATORE DI FLUSSO CILINDRICO PER CILINDRI FEMMINA
FLOW REGULATOR PARALLEL FOR CYLINDER FEMALE THREAD

CODE	A	B	C	D	NI/min*		
A160 M5	M5	3,5	24,5	10,5	45	8	25
A160 1/8	G1/8	4,5	31,5	16,0	310	14	25
A160 1/4	G1/4	6,5	38,0	22,0	810	17	25
A160 3/8	G3/8	8,5	47,0	32,0	1040	20	25
A160 1/2	G1/2	10,0	55,0	32,0	2200	26	25

A161

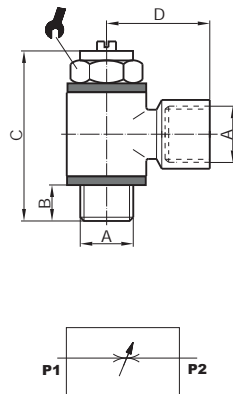

REGOLATORE DI FLUSSO CILINDRICO BIDIREZIONALE FEMMINA
FLOW REGULATOR PARALLEL BIDIRECTIONAL FEMALE THREAD

CODE	A	B	C	D	NI/min*		
A161 M5	M5	3,5	24,5	10,5	45	8	25
A161 1/8	G1/8	4,5	31,5	16,0	310	14	25
A161 1/4	G1/4	6,5	38,0	22,0	810	17	25
A161 3/8	G3/8	8,5	47,0	32,0	1040	20	25
A161 1/2	G1/2	10,0	55,0	32,0	2200	26	25

NSF

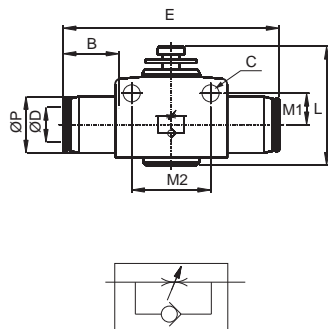

REGOLATORE DI FLUSSO IN LINEA UNIDIREZIONALE
FLOW REGULATOR UNIDIRECTIONAL IN LINE

CODE	ØD	ØP	L(max)	E	C	B	M1	M2	
NSF 0400B	4	10,5	33,3	45,1	3,3	16,3	5,9	14,8	50
NSF 0600B	6	12,5	39,5	50,3	4,3	17,6	8,3	20,5	50
NSF 0800B	8	14,5	42,1	55,7	4,4	18,7	9,8	23,0	25
NSF 1000B	10	17,5	49,0	61,2	4,4	19,6	10,7	28,0	20
NSF 1200B	12	20,5	53,6	69,8	4,4	21,9	11,7	32,0	15



La valvola selettore ha il compito di comandare due diversi ingressi selezionando uno o l'altro ma di utilizzare una sola uscita.

The selective valve can control two different inputs, choosing one or the other, but using only one way out.

DATI TECNICI / TECHNICAL DATA

Fluido / Fluid	aria con o senza lubrificazione / lubricated or non lubricated air
Pressione di esercizio / Pressure range	2 - 10bar
Temperatura di esercizio / Temperature range	-10 c° - +60c°
Portata nominale a 6 bar / Nominal flow rate of 6 bar	1/8=400NI/min 1/4=1300NI/min

COMPONENTI / COMPONENTS

Corpo / Body	Alluminio anodizzato / aluminium anodized
Inserto interno / Internal part	Ottone/ Brass
Guarnizione / Seal	NBR

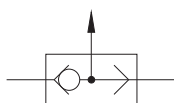
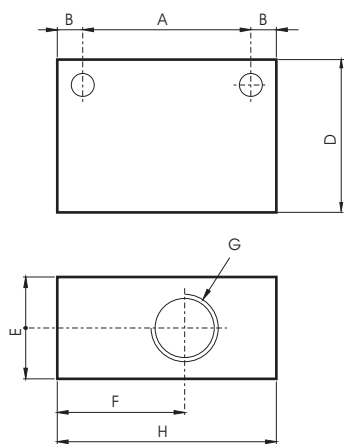

CODE

VS0101	1/8
VS0201	1/4

	A	B	D	E	F	H
1/8	20	4.5	25	15	14.5	34.8
1/4	33	5	30	20	25	43



Questa valvola consente il passaggio dell'aria solamente in un senso bloccandola nel senso opposto.
Sono disponibili con filetto maschio, femmina maschio/tubo o tubo/tubo in diverse dimensioni.

This valve allows the transit of the air only in one way, the valve stops it in the opposite way.
They are available with male or female thread, in several dimensions.

DATI TECNICI / TECHNICAL DATA

Fluido / Fluid	aria con o senza lubrificazione / lubricated or non lubricated air
Pressione di esercizio / Pressure range	2 - 8 bar
Temperatura di esercizio / Temperature range	-20 c° - +80c°

COMPONENTI / COMPONENTS

Corpo / Body	Ottone OT58 nichelato / nickel-plated brass
Molla / Spring	Acciaio inox / stainless steel
Otturatore / Shutter	Ottone OT58 nichelato / nickel-plated brass
Guarnizione / Seal	NBR

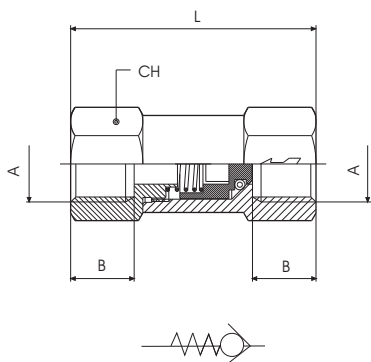

**VALVOLA DI NON RITORNO FEMMINA/FEMMINA
NON-RETURN VALVE FEMALE/FEMALE**

CODE	A	B	L	CH
VR40011	M5	5,5	26,5	8
VR40012	1/8	8,5	35,5	13
VR40013	1/4	11	43	17
VR40014	3/8	12	58	24
VR40015	1/2	15	63	24

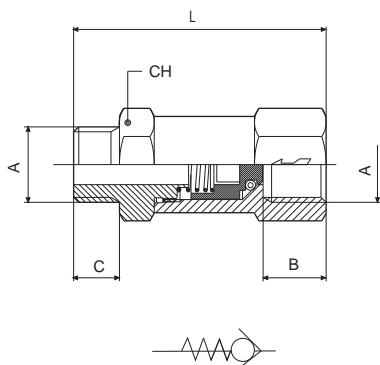

**VALVOLA DI NON RITORNO MASCHIO/FEMMINA
NON-RETURN VALVE MALE/FEMALE**

CODE	A	B	C	L	CH
VR40021	M5	5,5	4	34,5	8
VR40022	1/8	8,5	6	37,5	14
VR40023	1/4	11	8	46,6	17
VR40024	3/8	12	9	61	24
VR40025	1/2	15	10	64	24

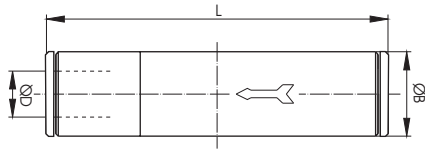

VALVOLA DI NON RITORNO TUBO / TUBO
TUBE / TUBE NON-RETURN VALVE

CODE	ØD	ØB	L
VR400504	4	9	44,5
VR400506	6	11	50
VR400508	8	13	53,5

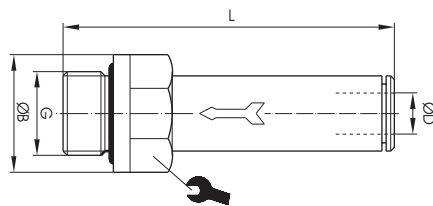

VALVOLA DI NON RITORNO FILETTO MASCHIO / TUBO
MALE THREAD / TUBE NON-RETURN VALVE

CODE	ØD	G	ØB	L	
VR4003104	4	M5	8	37	9
VR4003204	4	1/8	13	30	11
VR4003206	6	1/8	13	37,5	13
VR4003306	6	1/4	16	38	14
VR4003208	8	1/8	13	38	15
VR4003308	8	1/4	16	39	16
VR4003310	10	1/4	16	42,5	18
VR4003410	10	3/8	20	42,5	18
VR4003512	12	1/2	25	45	22
VR4003514	14	1/2	25	52,5	25



VALVOLA A SCARICO RAPIDO
QUICK EXHAUST VALVE



La valvola a scarico rapido permette di evacuare rapidamente l'aria presente nel cilindro per aumentarne la velocità.
 Si consiglia il montaggio direttamente sulle alimentazioni del cilindro.

The quick exhaust valve allows to exhaust the air in the cylinder to increase the speed.
 We suggest the mounting directly on the cylinder's supply.

DATI TECNICI / TECHNICAL DATA

Fluido / Fluid	aria con o senza lubrificazione / lubricated or non lubricated air
Pressione di esercizio / Pressure range	1 - 10bar
Temperatura di esercizio / Temperature range	-10 c° - +70c°

COMPONENTI / COMPONENTS

Corpo / Body	Ottone OT58 nichelato / Nickel-plated brass
Coperchio / Cover	Ottone OT58 nichelato / Nickel-plated brass
Guarnizione / Seal	NBR

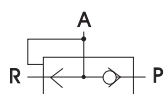
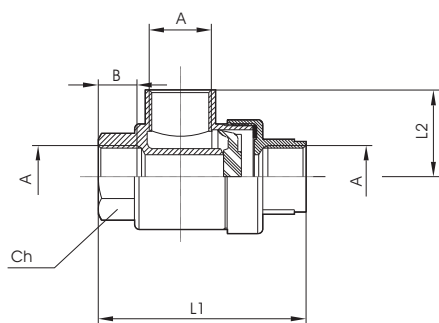

CODE	A
VR40061	M5
VR40062	1/8
VR40063	1/4
VR40064	3/8
VR40065	1/2

A	B	L1	L2	CH
M5	4	25	10	17
1/8	8,5	42	19,5	15
1/4	11	54	25	19
3/8	12	60,5	26,5	22
1/2	15	72	32	26



Le valvole di blocco sono dispositivi pneumatici che garantiscono il bloccaggio della corsa del cilindro in caso di caduta di pressione dell'impianto. Vengono montati direttamente sulle alimentazioni del cilindro e non interferiscono sul normale funzionamento del cilindro stesso.

The stop valves is a pneumatic device that locks the cylinder's stroke in case of loss of pressure in the system. The valves are mounted directly on the cylinder's supply and do not interfere with the functioning of the cylinder.

DATI TECNICI / TECHNICAL DATA

Fluido / Fluid	aria con o senza lubrificazione / lubricated or non lubricated air
Pressione di esercizio / Pressure range	1 - 10bar
Temperatura di esercizio / Temperature range	-10 c° - +70c°
Filetti / thread	1/8 , 1/4 , 3/8 , 1/2
Tubo / Tube	4mm , 6mm , 8mm , 10mm , 12mm

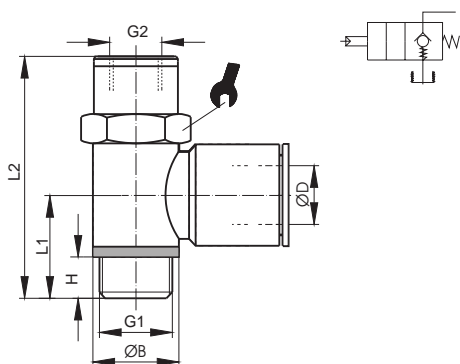

VALVOLA DI BLOCCO
STOP VALVE

CODE	ØD	G1	ØB	G2	H	L1	L2	CH
VO0204	4	1/8	14	M5	6	15,5	42	13
VO0206	6	1/8	14	M5	6	15,5	42	13
VO0306	6	1/4	18	M5	8	18,5	47	17
VO0208	8	1/8	14	M5	6	15,5	42	13
VO0308	8	1/4	18	M5	8	18,5	47	17
VO0408	8	3/8	21	1/8	9	21	53,5	20
VO0310	10	1/4	18	M5	8	18,5	47	17
VO0410	10	3/8	21	1/8	9	21	53,5	20
VO0312	12	1/4	18	M5	8	18,5	47	17
VO0412	12	3/8	21	1/8	9	21	53,5	20

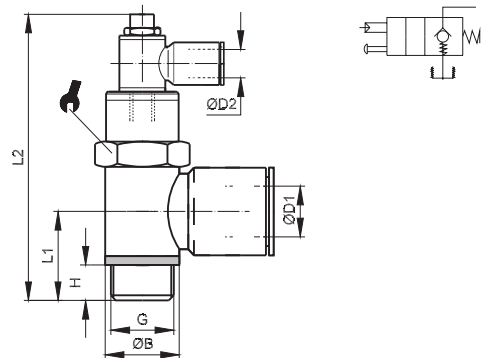

VALVOLA DI BLOCCO CON COMANDO PNEUMATICO
STOP VALVE WITH PNEUMATIC OVERRIDE DEVICE

CODE	ØD1	G	ØB	ØD1	H	L1	L2	CH
VO2204	4	1/8	14	4	6	15,5	62	13
VO2206	6	1/8	14	4	6	15,5	62	13
VO2306	6	1/4	18	4	8	18,5	67	17
VO2208	8	1/8	14	4	6	15,5	62	13
VO2308	8	1/4	18	4	8	18,5	67	17
VO2408	8	3/8	21	6	9	21	76,5	20
VO2310	10	1/4	18	4	8	18,5	67	17
VO2410	10	3/8	21	6	9	21	76,5	20
VO2312	12	1/4	18	4	8	18,5	67	17
VO2412	12	3/8	21	6	9	21	76,5	20

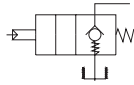
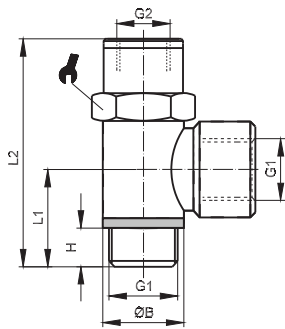

VALVOLA DI BLOCCO FEMMINA
FEMALE STOP VALVE

CODE	G1	ØB	G2	H	L1	L2	CH
VO02	1/8	15	M5	6	15,5	42	13
VO03	1/4	18	M5	8	18,5	47	17
VO04	3/8	22	1/8	9	21	53,5	20
VO05	1/2	27	1/8	10	24,5	60	25

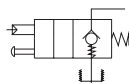
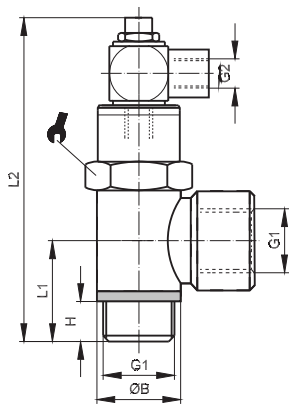

VALVOLA DI BLOCCO FEMMINA CON COMANDO PNEUMATICO
FEMALE STOP VALVE WITH PNEUMATIC OVERRIDE DEVICE

CODE	G1	ØB	G2	H	L1	L2	CH
VO22	1/8	15	M5	6	15,5	62	13
VO23	1/4	18	M5	8	18,5	67	17
VO24	3/8	22	1/8	9	21	76,5	20
VO25	1/2	27	1/8	10	24,5	83	25



Il pressostato permette di trasformare un segnale pneumatico in un segnale elettrico.

The pressure switch allows to change the signal from pneumatic into electric

DATI TECNICI / TECHNICAL DATA

Fluido / Fluid	aria con o senza lubrificazione / lubricated or non lubricated air
Temperatura di esercizio / Temperature range	-10 c° - +60c
Campo di taratura / setting range	1 - 10bar
Tolleranza a 20 C° / Tolerance at 20 C°	0,5bar
Tensione massima / Max tension	48V AC

MATERIALI / MATERIALS

Corpo / Body	Ottone OT58 / Brass OT58
Membrana / Diaphragm	Gomma / Rubber
Contatti / Electrical contacts	Argentati / Silver plated

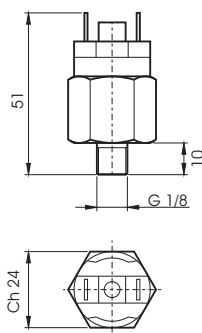

CODE

PR211 NC

PR212 NA / NO

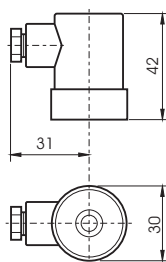

CAPPUCCIO 90° / CAP 90°

CODE

TX0017

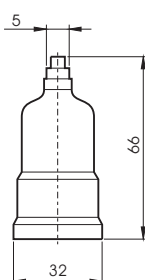

CAPPUCCIO IN LINEA / IN LINE CAP

CODE

TX0018



Il trasduttore pneumo-elettrico permette di trasformare un segnale pneumatico in un segnale elettrico.

The pneumo.electric transducer allows to change the signal from pneumatic into electric

DATI TECNICI / TECHNICAL DATA

Fluido / Fluid	aria con o senza lubrificazione / lubricated or non lubricated air
Pressione di esercizio / Pressure range	1 - 10bar
Temperatura di esercizio / Temperature range	-10 c° - +60c°
Frequenza massima / Max frequency	6000 Cicli/ora/Cicles/hour
Grado di isolamento IP / IP degree	IP 40
Tensione di isolamento / Rated isolation voltage	250 V
Corrente nominale termica / Rated thermal current	16 A
Fusibile / Fuse	16 A

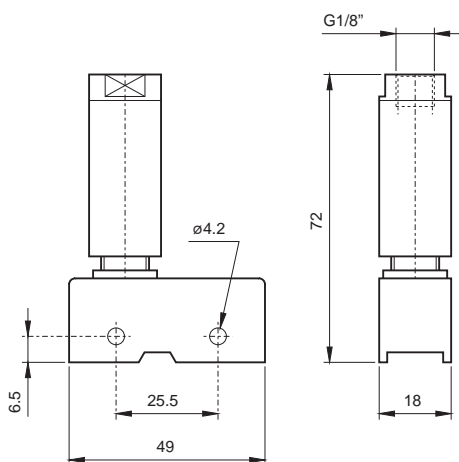

CODE

TR21





Le valvole a corsoio sono vere e proprie valvole di intercettazione on/off che consentono lo scarico dell'aria dall'impianto durante la commutazione in off.

The slide valves with switch on/off, allow the exhaust of the air (position off).

DATI TECNICI / TECHNICAL DATA

Fluido / Fluid	aria con o senza lubrificazione / lubricated or non lubricated air
Pressione di esercizio / Pressure range	0,3 - 10bar
Temperatura di esercizio / Temperature range	-18 c° - +70c°

COMPONENTI / COMPONENTS

Corsoio / Slide	Alluminio / Aluminium
Stelo / Rod	Ottone OT58 nichelato / Brass OT58 nichel
Guarnizione / Seal	NBR

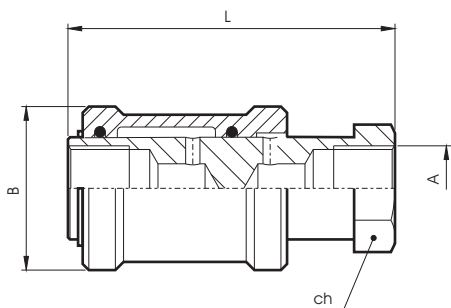

CODE	A
VR40032	1/8
VR40033	1/4
VR40034	3/8
VR40035	1/2

A	B	L	CH
1/8	25	48	14
1/4	30	58	17
3/8	35	70	22
1/2	40	80	26



DATI TECNICI / TECHNICAL DATA

Fluido / Fluid	aria con o senza lubrificazione / lubricated or non lubricated air
Pressione di esercizio / Pressure range	1 - 10bar
Temperatura di esercizio / Temperature range	-10 c° - +60c°

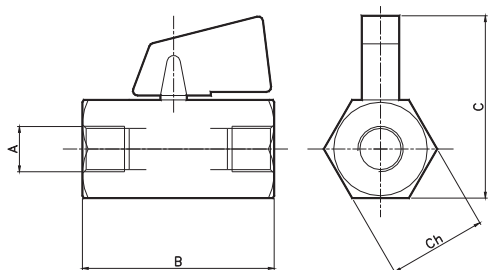

RUBINETTO A SFERA FEMMINA/FEMMINA
MINI BALL VALVE FEMALE-FEMALE

CODE	A	DN	B	C	CH
VR40042	1/8	6	39	38	21
VR40043	1/4	8	40	38	21
VR40044	3/8	8	42	38	21
VR40045	1/2	10	48	42	25

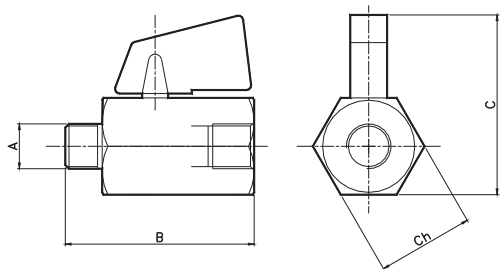

RUBINETTO A SFERA FEMMINA/MASCHIO
MINI BALL VALVE MALE-FEMALE

CODE	A	DN	B	C	CH
VR40052	1/8	6	39	38	21
VR40053	1/4	8	39	38	21
VR40054	3/8	8	40	38	21
VR40055	1/2	10	46	42	25



Il ripartitore è un corpo in alluminio in cui vengono praticati dei fori filettati dedicati al montaggio di raccordi che appunto ripartiscono l'aria dove questa sia necessaria.

The manifold has an aluminium body with threads for the air distribution

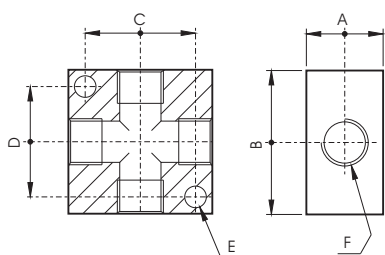

**RIPARTITORE A CROCE
TEE CROSS MANIFOLD**

CODE	F	A	B	C	D	E
RC40304502	1/8	16	30	23	22	4,5
RC40304503	1/4	20	40	30	27	5,5
RC40304504	3/8	25	50	38	39	6,5
RC40304505	1/2	25	50	38	39	6,5

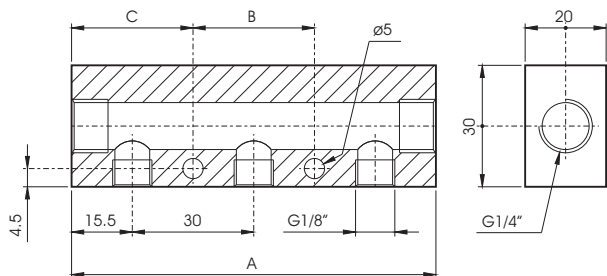

**RIPARTITORE SINGOLO 1/4 - 1/8
SINGLE MANIFOLD 1/4 - 1/8**

CODE	N°	A	B	C
RC40302407	2	61	50	5,5
RC40302507	3	91	30	30,5
RC40302607	4	121	60	30,5
RC40302707	5	151	90	30,5
RC40302807	6	181	120	30,5

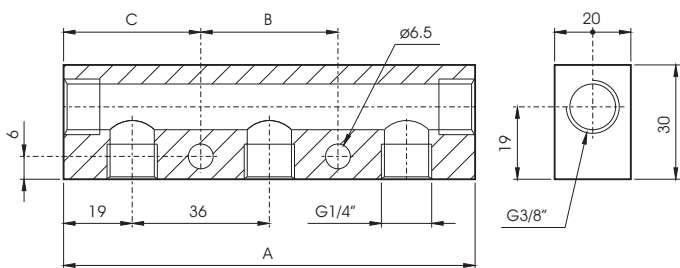

**RIPARTITORE SINGOLO 3/8 - 1/4
SINGLE MANIFOLD 3/8 - 1/4**

CODE	N°	A	B	C
RC40302417	2	74	61	6,5
RC40302517	3	110	36	37
RC40302617	4	146	72	37
RC40302717	5	182	108	37
RC40302817	6	218	144	37

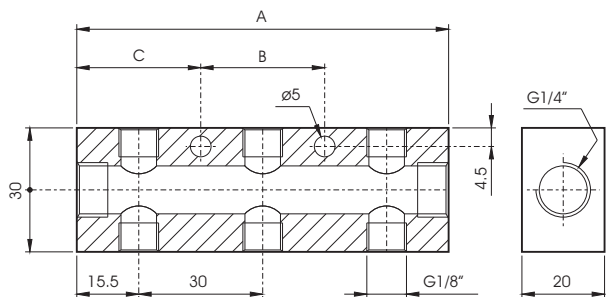

RIPARTITORE DOPPIO 1/4 - 1/8
DOUBLE MANIFOLD 1/4 - 1/8

CODE	N°	A	B	C
RC40302907	2	61	50	5,5
RC40303007	3	91	30	30,5
RC40303107	4	121	60	30,5
RC40303207	5	151	90	30,5

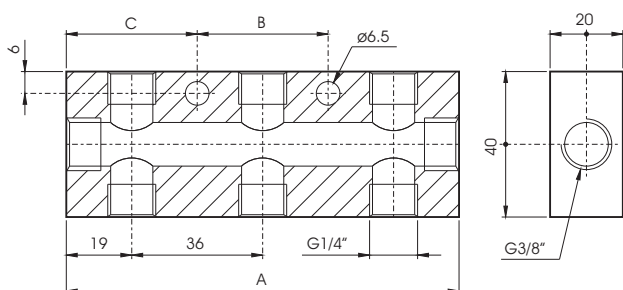

RIPARTITORE DOPPIO 3/8 - 1/4
DOUBLE MANIFOLD 3/8 - 1/4

CODE	N°	A	B	C
RC40302917	2	74	61	6,5
RC40303017	3	110	36	37
RC40303117	4	146	72	37
RC40303217	5	182	108	37
RC40303317	6	218	144	37

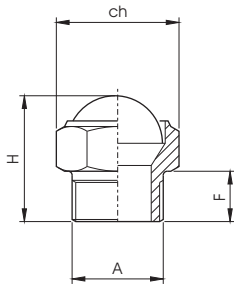

CODE	A	F	H	CH
SI40012	1/8	6	15	13
SI40013	1/4	7	18	16
SI40014	3/8	8	20	19
SI40015	1/2	10	22	24

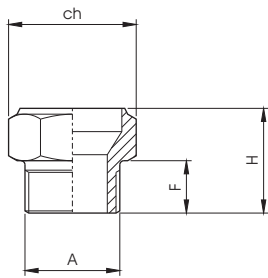

CODE	A	F	H	CH
SI40022	1/8	6	13	13
SI40023	1/4	7	14	16
SI40024	3/8	8	18	19
SI40025	1/2	10	19	24

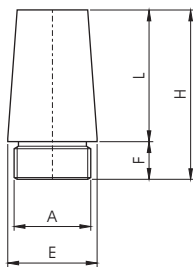

CODE	A	E	F	L	H
SI40032	1/8	11,5	4,5	13,0	17,5
SI40033	1/4	15	6	18	24
SI40034	3/8	19	7	24	31
SI40035	1/2	23	8	29	37

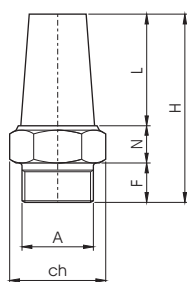

CODE	A	N	F	L	H	CH
SI40042	1/8	8	6	15	29	13
SI40043	1/4	8	7	17	32	16
SI40044	3/8	7	8	25	40	19
SI40045	1/2	9	9	27	45	24

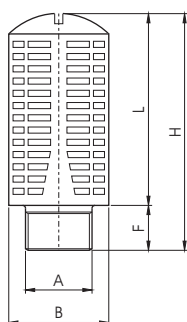

CODE	A	B	F	L	H
SI40052	1/8	15	6	26,5	32,5
SI40053	1/4	19,5	8	35	43
SI40054	3/8	24,5	11	47	58
SI40055	1/2	24,5	11	47	58

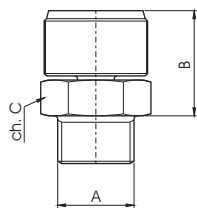

REGOLATORE DI SCARICO CON SILENZIATORE
EXHAUST REGULATOR WITH SILENCER

CODE	A	B-min	B-max	CH
SI40062	1/8	14	19	12
SI40063	1/4	17	22	15
SI40064	3/8	18	24	19
SI40065	1/2	18	24	22

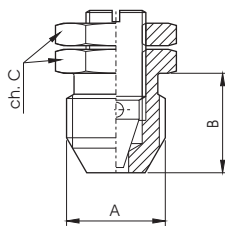

REGOLATORE DI SCARICO DI PRECISIONE
PRECISION EXHAUST REGULATOR

CODE	A	B	C
SI40072	1/8	11	12
SI40073	1/4	13.3	14

FILTRI
 FILTERS



PAGE
 3.5

REGOLATORE
 REGULATOR



PAGE
 3.6

REGOLATORE SCARICO RAPIDO
 QUICK EXHAUST REGULATOR



PAGE
 3.7

REGOLATORE PER ACQUA
 WATER REGULATOR



PAGE
 3.8

FILTROREGOLATORE
 FILTER REGULATOR



PAGE
 3.9

LUBRIFICATORE
 LUBRICATOR



PAGE
 3.10

FILTROREGOLATORE+LUBRIFICATORE (FR+L)
 FILTERREGULATOR+LUBRICATOR (FR+L)



PAGE
 3.11

FILTRO+REGOLATORE+LUBRIFICATORE (F+R+L)
 FILTER+REGULATOR+LUBRICATOR (F+R+L)



PAGE
 3.12

FILTRI
 FILTERS



PAGE
 3.13

REGOLATORE
 REGULATOR



PAGE
 3.15

FILTROREGOLATORE
 FILTER REGULATOR



PAGE
 3.16

LUBRIFICATORE
 LUBRICATOR



PAGE
 3.18

FILTROREGOLATORE+LUBRIFICATORE (FR+L)
 FILTERREGULATOR+LUBRICATOR (FR+L)



PAGE
 3.20

FILTRO+REGOLATORE+LUBRIFICATORE (F+R+L)
 FILTER+REGULATOR+LUBRICATOR (F+R+L)



PAGE
 3.21

AVVIATORE PROGRESSIVO CON SCARICO RAPIDO
 SOFT START VALVE WITH QUICK EXHAUST



PAGE
 3.22

VALVOLA SELETRICE
 SHOT OFF VALVE



PAGE
 3.23

FILTRO + LUBRIFICATORE (F+L)
 FILTER + LUBRICATOR (F+L)



PAGE
 3.25

VALVOLA+FILTROREGOLATORE+LUBRIFICATORE (V+FR+L)
 VALVE+FILTREGULATOR+LUBRICATOR (V+FR+L)



PAGE
 3.26

VALVOLA+FILTRO+REGOLATORE+LUBRIFICATORE (V+F+R+L)
 VALVE+FILTER+REGULATOR+LUBRICATOR (V+F+R+L)



PAGE
 3.27

STAFFA DI FISSAGGIO
 CLAMP BRACKET



PAGE
 3.28

MANOMETRO
 MANOMETER



PAGE
 3.28



DATI TECNICI / TECHNICAL DATA

Fluido / Fluid	Aria / Air
Pressione Max / Maximum pressure	15 bar
Temperatura / Temperature	-10 / +50° C
Grado di filtrazione / Filtration grade	5 - 20 - 50µm
Portata a 6 bar con Δp 1bar / 6bar flow rate with Δp 1bar	800 NI/min
Capacità tazza / Bowl capacity	17,5cm ³

PRODOTTI STANDARD / STANDARD PRODUCTS

CODICE CODE	TAGLIA SIZE	FILETTO THREAD	FILTRAZIONE FILTRATION	PORTATA FLOW RATE	SCARICO EXHAUST
XF0121	0	1/8	20µm	800NI/min	S/M
XF0221	0	1/4	20µm	800NI/min	S/M

S/M: Semiautomatico Manuale / Semi automatic Manual

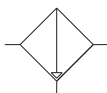
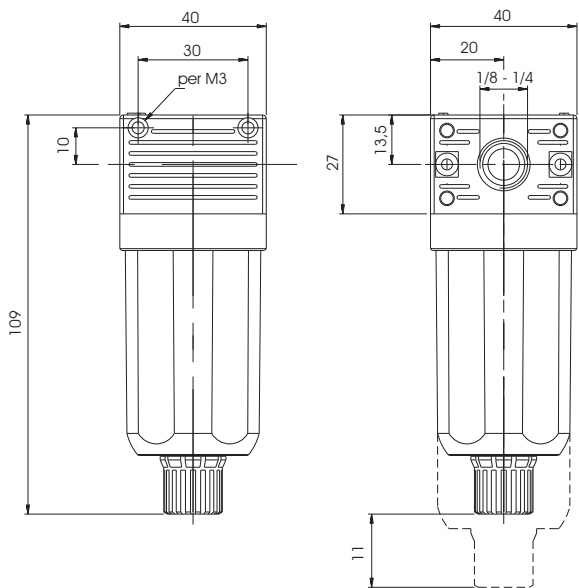

COMPONENTI / COMPONENTS

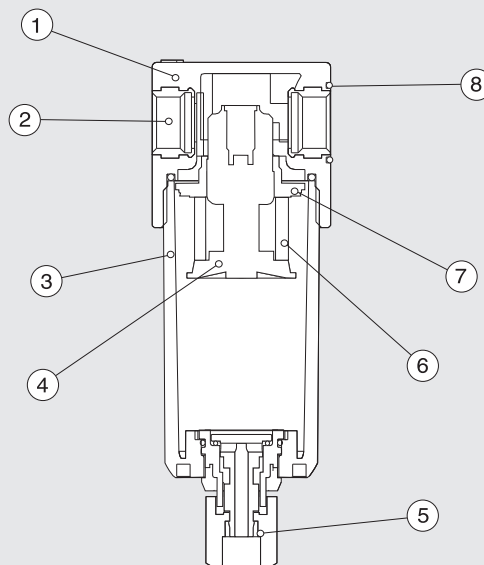

1	Corpo / body	tecnopolimero / technopolymer
2	Insero filettato / threaded insert	ottone / brass
3	Tazza / bowl	tecnopolimero / technopolymer
4	Portafiltro / filter ring	tecnopolimero / technopolymer
5	Scarico condensa / condensate exhaust	tecnopolimero / technopolymer
6	Cartuccia filtrante / filtering cartridge	PE
7	Centrifugatore / slinger	tecnopolimero / technopolymer
8	o-ring / o-ring	NBR



DATI TECNICI / TECHNICAL DATA

Fluido / Fluid	Aria / Air
Pressione Max / Maximum pressure	15 bar
Temperatura / Temperature	-10 / +50° C
Campo di regolazione / Regulation range	0-2bar 0-4bar 0-8bar standard 0-12bar
Portata a 6 bar con Δp 1bar / 6bar flow rate with Δp 1bar	600NI/min
Attacco manometro / Manometer fastening	1/8

CHIAVE DI CODIFICA / KEY TO TYPE NUMBER

XR 0,0,0,0

CAMPO DI REGOLAZIONE
REGULATION RANGE

- 1=0-2bar
- 2=0-4bar
- 3=0-8bar STANDARD
- 4=0-12bar

FILETTO / THREAD

- 1=G 1/8 (TAGLIA 0)
- 2=G 1/4 (TAGLIA 0)

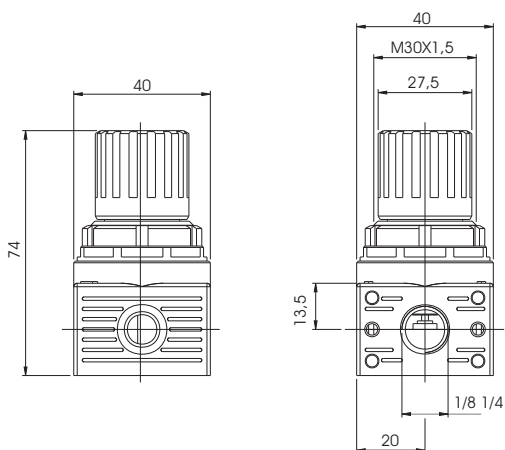

COMPONENTI / COMPONENTS

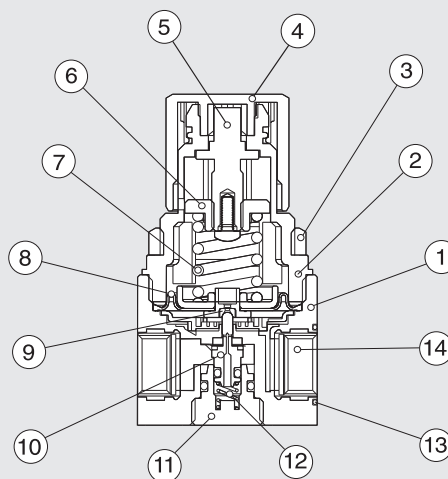

1	corpo / body	tecnopolimero / technopolymer
2	campana / bell	tecnopolimero / technopolymer
3	ghiera di fissaggio / fixing nut	tecnopolimero / technopolymer
4	manopola / knob	tecnopolimero / technopolymer
5	vite di registro / register screw	ottone / brass
6	chiocciola / female screw	ottone / brass
7	molla di registro / register spring	acciaio / steel
8	membrana / membrane	
9	guarnizione / seal	NBR
10	otturatore / shutter	NBR
11	tappo / plug	tecnopolimero / technopolymer
12	molla / spring	acciaio inox / stainless steel
13	o-ring	NBR
14	inserto filettato / threaded insert	ottone / brass



DATI TECNICI / TECHNICAL DATA

Fluido / Fluid	Aria / Air
Pressione Max / Maximum pressure	15 bar
Temperatura / Temperature	-10 / +50° C
Campo di regolazione / Regulation range	0-2bar 0-4bar 0-8bar standard 0-12bar
Portata a 6 bar con Δp 1bar / 6bar flow rate with Δp 1bar	600l/min
Attacco manometro / Manometer fastening	1/8

CHIAVE DI CODIFICA / KEY TO TYPE NUMBER

XM 0,0,0,0

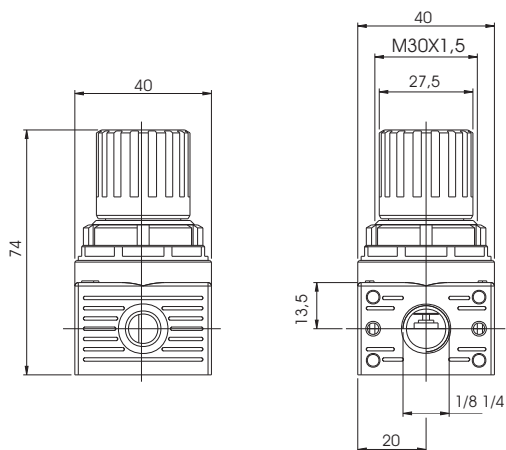
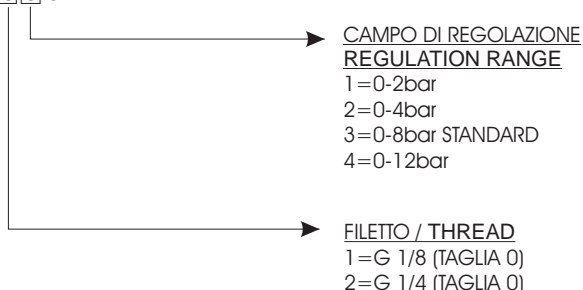

COMPONENTI / COMPONENTS

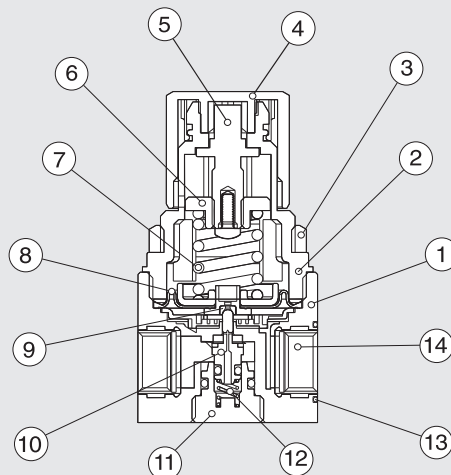

1	corpo / body	tecnopolimero / technopolymer
2	campana / bell	tecnopolimero / technopolymer
3	ghiera di fissaggio / fixing nut	tecnopolimero / technopolymer
4	manopola / knob	tecnopolimero / technopolymer
5	vite di registro / register screw	ottone / brass
6	chiocciola / female screw	ottone / brass
7	molla di registro / register spring	acciaio / steel
8	membrana / membrane	
9	guarnizione / seal	NBR
10	otturatore / shutter	NBR
11	tappo / plug	tecnopolimero / technopolymer
12	molla / spring	acciaio inox / stainless steel
13	o-ring	NBR
14	inserto filettato / threaded insert	ottone / brass



DATI TECNICI / TECHNICAL DATA

Fluido / Fluid	Aria / Air
Pressione Max / Maximum pressure	15 bar
Temperatura / Temperature	-10 / +50° C
Campo di regolazione / Regulation range	0-2bar 0-4bar 0-8bar standard 0-12bar
Attacco manometro / Manometer fastening	1/8

CHIAVE DI CODIFICA / KEY TO TYPE NUMBER

XQ 0,0,0,0

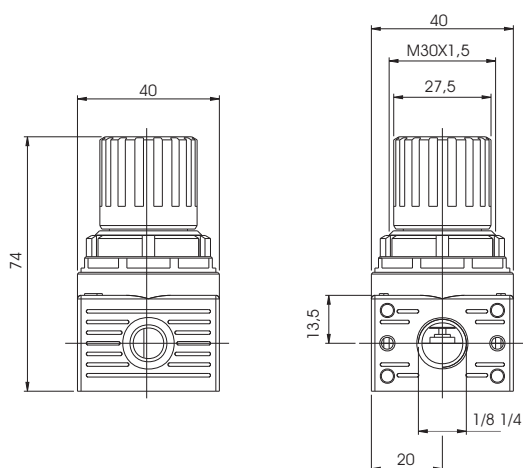
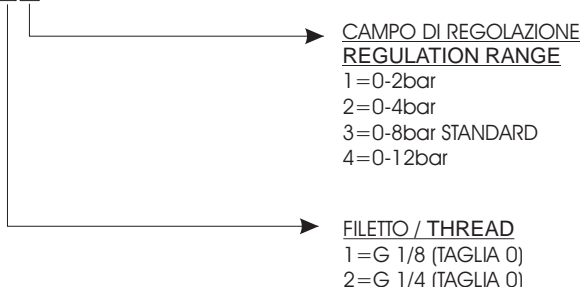

COMPONENTI / COMPONENTS

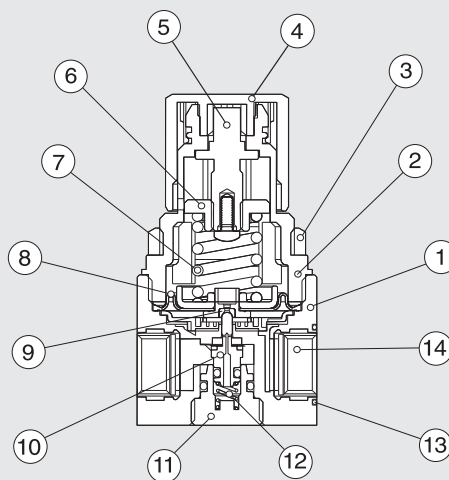

1	corpo / body	tecnopolimero / technopolymer
2	campana / bell	tecnopolimero / technopolymer
3	ghiera di fissaggio / fixing nut	tecnopolimero / technopolymer
4	manopola / knob	tecnopolimero / technopolymer
5	vite di registro / register screw	ottone / brass
6	chiocciola / female screw	ottone / brass
7	molla / spring	acciaio / steel
8	membrana / membrane	
9	guarnizione / seal	NBR
10	otturatore / shutter	NBR
11	tappo / plug	tecnopolimero / technopolymer
12	molla / spring	acciaio inox / stainless steel
13	o-ring	NBR
14	inserto filettato / threaded insert	ottone / brass



DATI TECNICI / TECHNICAL DATA

Fluido / Fluid	Aria / Air
Pressione Max / Maximum pressure	15 bar
Temperatura / Temperature	-10 / +50° C
Campo di regolazione / Regulation range	0-2bar 0-4bar 0-8bar standard 0-12bar
Grado di filtrazione / Filtration grade	5µm - 20µm standard - 50µm
Portata a 6 bar con Δp 1bar / 6bar flow rate with Δp 1bar	600NI/min
Attacco manometro / Manometer fastening	1/8
Capacità tazza / Bowl capacity	17,5cm ³

CHIAVE DI CODIFICA / KEY TO TYPE NUMBER

XPO 0,0,0,1

- **GRADO DI FILTRAZIONE / FILTRATION GRADE**
1 = 5 µm
2 = 20 µm STANDARD
3 = 50 µm
- **FILETTO / THREAD**
1 = G 1/8
2 = G 1/4
- **CAMPO DI REGOLAZIONE / REGULATION RANGE**
1 = 0-2bar
2 = 0-4bar
3 = 0-8bar STANDARD
4 = 0-12bar

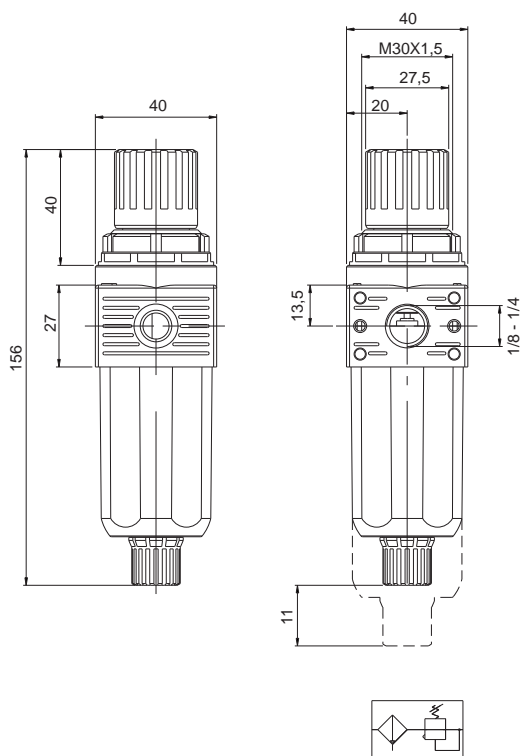

COMPONENTI / COMPONENTS

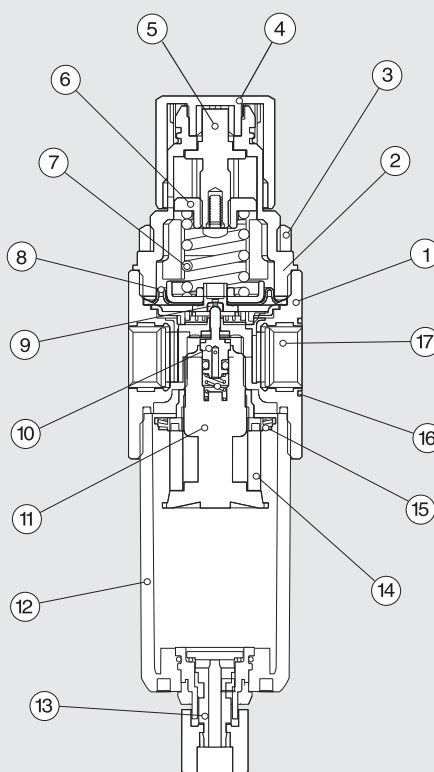

1	corpo / body	tecnopolimero / technopolymer
2	campana / bell	tecnopolimero / technopolymer
3	ghiera / fixing nut	tecnopolimero / technopolymer
4	manopola / knob	tecnopolimero / technopolymer
5	vite di registro / register screw	ottone / brass
6	chiocciola / female screw	ottone / brass
7	molla di registro / register spring	acciaio / steel
8	membrana / membrane	
9	guarnizione / seal	NBR / NBR
10	otturatore / shutter	NBR / NBR
11	portafiltro / filter ring	tecnopolimero / technopolymer
12	tazza / bowl	tecnopolimero / technopolymer
13	scarico cond. / cond. exhaust	tecnopolimero / technopolymer
14	cartuccia / cartridge	PE / PE
15	centrifugatore / slinger	tecnopolimero / technopolymer
16	o-ring	NBR / NBR
17	inserto filettato / threaded insert	ottone / brass



DATI TECNICI / TECHNICAL DATA

Fluido / Fluid	Aria / Air
Pressione Max / Maximum pressure	15 bar
Temperatura / Temperature	-10 / +50° C
Portata a 6 bar con Δp 1bar / 6bar flow rate with Δp 1bar	700NI/min
Capacità tazza / Bowl capacity	28 cm3

PRODOTTI STANDARD / STANDARD PRODUCTS

CODICE CODE	TAGLIA SIZE	FILETTO THREAD	PORTATA FLOW RATE
XL0110	0	1/8	700NI/min
XL0210	0	1/4	700NI/min

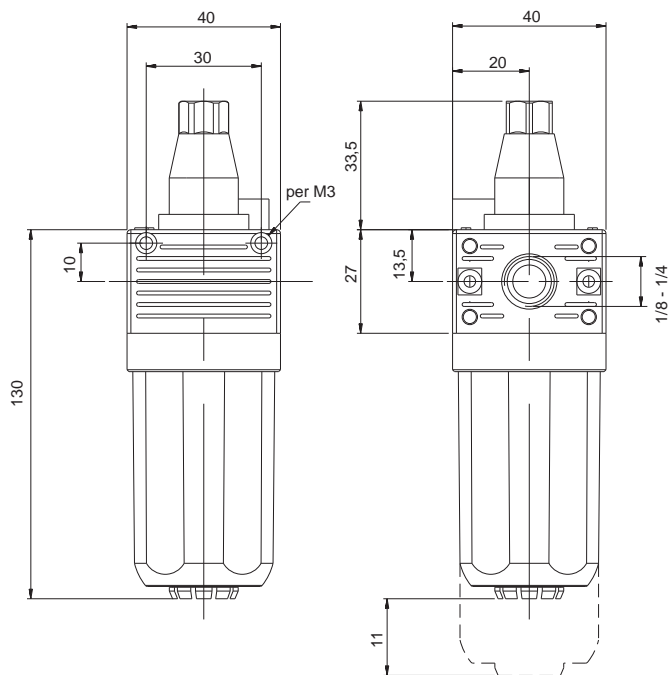

COMPONENTI / COMPONENTS

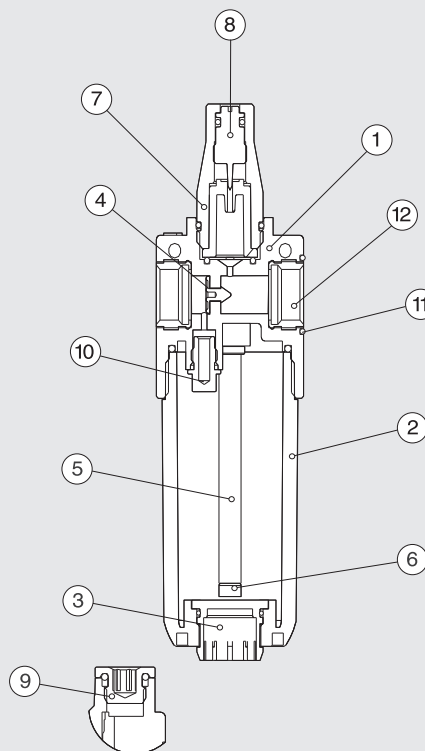

1	corpo / body	tecnopolimero / technopolymer
3	tazza / bowl	tecnopolimero / technopolymer
3	tappo / plug	tecnopolimero / technopolymer
4	membrana / membrane	
5	tubo / tube	PA11
6	filtrino / small filter	
7	cupola / dome	tecnopolimero / technopolymer
8	spillo / pin	ottone / brass
9	tappo / plug	ottone / brass
10	diffusore / air diffuser	ottone / brass
11	o-ring	NBR



DATI TECNICI / TECHNICAL DATA

Fluido / Fluid	Aria / Air
Pressione Max / Maximum pressure	15 bar
Temperatura / Temperature	-10 / +50° C
Campo di regolazione / Regulation range	0-2bar 0-4bar 0-8bar standard 0-12bar
Grado di filtrazione / Filtration grade	5µm - 20µm standard - 50µm
Portata a 6 bar con Δp 1bar / 6bar flow rate with Δp 1bar	260 Nl/min
Attacco manometro / Manometer fastening	1/8 1/4

CHIAVE DI CODIFICA / KEY TO TYPE NUMBER

XSO 0,0,0,1

**GRADO DI FILTRAZIONE
FILTRATION GRADE**
1 = 5 µm
2 = 20 µm STANDARD
3 = 50 µm

**CAMPO DI REGOLAZIONE
REGULATION RANGE**
1 = 0-2bar
2 = 0-4bar
3 = 0-8bar STANDARD
4 = 0-12bar

FILETTO / THREAD
1 = G 1/8
2 = G 1/4

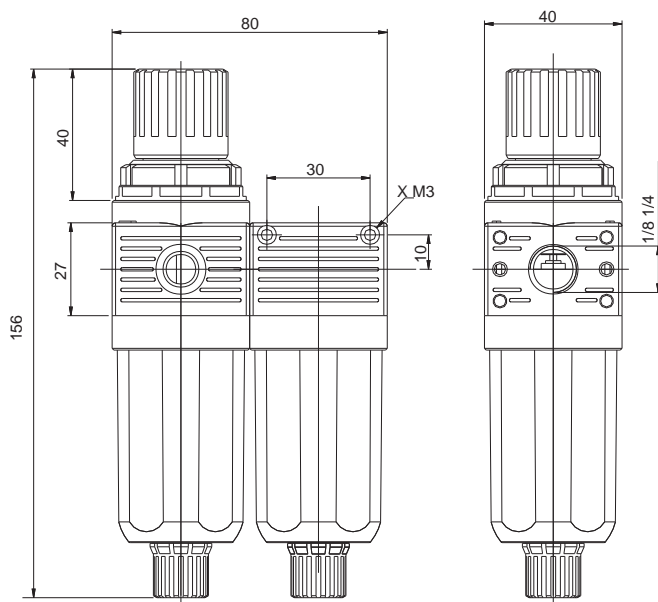



DATI TECNICI / TECHNICAL DATA

Fluido / Fluid	Aria / Air
Pressione Max / Maximum pressure	15 bar
Temperatura / Temperature	-10 / +50° C
Campo di regolazione / Regulation range	0-2bar 0-4bar 0-8bar standard 0-12bar
Grado di filtrazione / Filtration grade	5µm - 20µm standard - 50µm
Portata a 6 bar con Δp 1 bar / 6bar flow rate with Δp 1bar	280 Nl/min
Attacco manometro / Manometer fastening	1/8
Capacità tazza / Bowl capacity	17,5cm ³

CHIAVE DI CODIFICA / KEY TO TYPE NUMBER

XT0 0,0,0,1 1

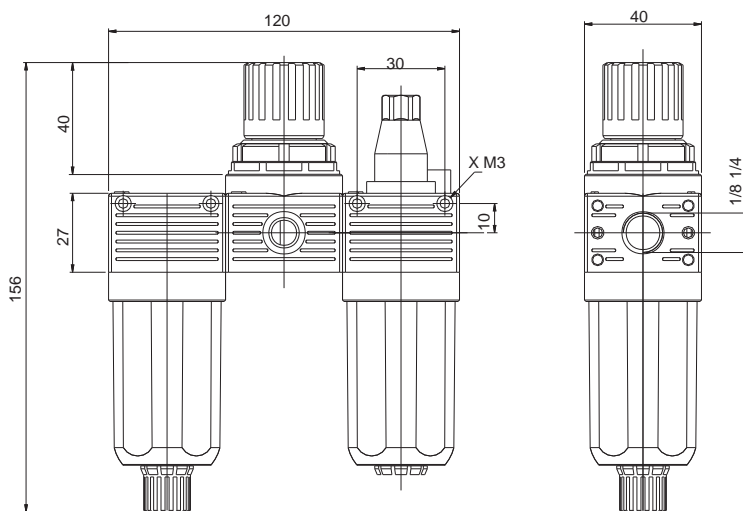
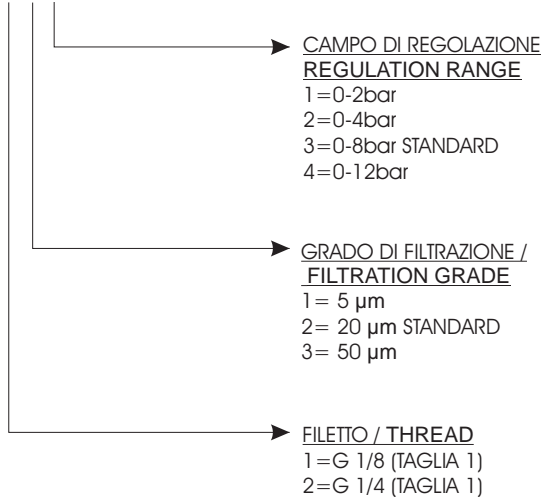



DATI TECNICI / TECHNICAL DATA

Fluido / Fluid	Aria / Air		
Pressione Max / Maximum pressure	15 bar		
Temperatura / Temperature	-10 / +50° C		
Grado di filtrazione / Filtration grade	5 - 20 - 50µm		
Portata a 6 bar con Δp 1bar / 6bar flow rate with Δp 1bar	1=1900 NI/min	2=3750NI/min	3=6250NI/min
Capacità tazza / Bowl capacity	1=22cm ³	2=46cm ³	3=89,5cm ³
Viti per fissaggio / Wall clamping screws	1=M4X14	2=M5X18	3=M6X20

PRODOTTI STANDARD / STANDARD PRODUCTS

CODICE CODE	TAGLIA SIZE	FILETTO THREAD	FILTRAZIONE FILTRATION	PORTATA FLOW RATE	SCARICO EXHAUST
XF1221	1	1/4	20µm	1900NI/min	S/M
XF1321	1	3/8	20µm	1900NI/min	S/M
XF2321	2	3/8	20µm	3750NI/min	S/M
XF2421	2	1/2	20µm	3750NI/min	S/M
XF2422	2	1/2	20µm	3750NI/min	A
XF3521	3	3/4	20µm	6250NI/min	S/M
XF3621	3	1"	20µm	6250NI/min	S/M
XF3622	3	1"	20µm	6250NI/min	A

S/M: Semiautomatico Manuale / Semi automatic Manual
A: Automatico / Automatic

CHIAVE DI CODIFICA / KEY TO TYPE NUMBER

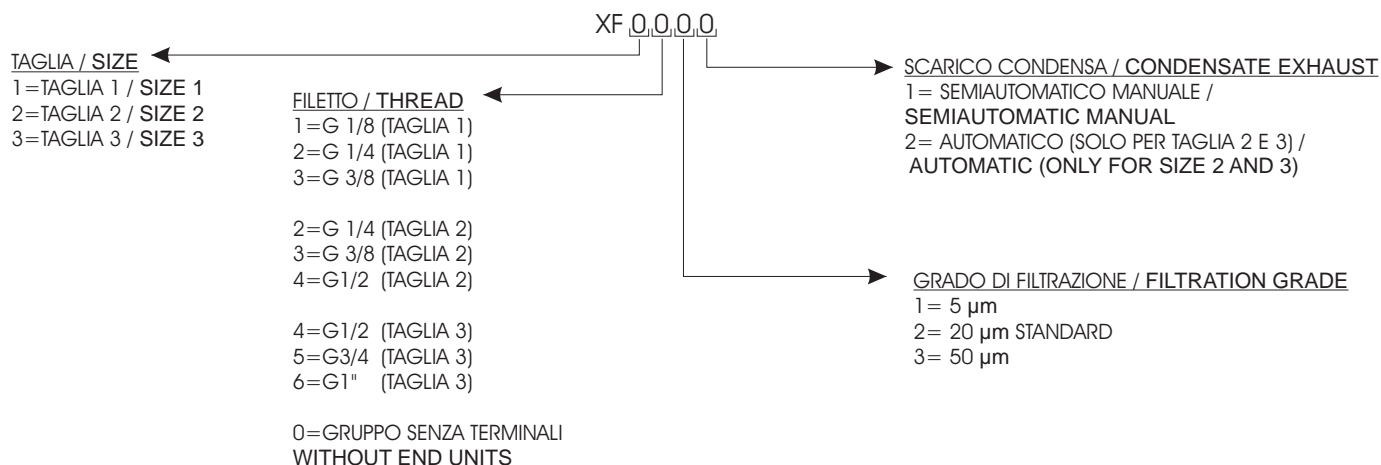

CARATTERISTICHE DI FLUSSO / FLOW CHARACTERISTICS

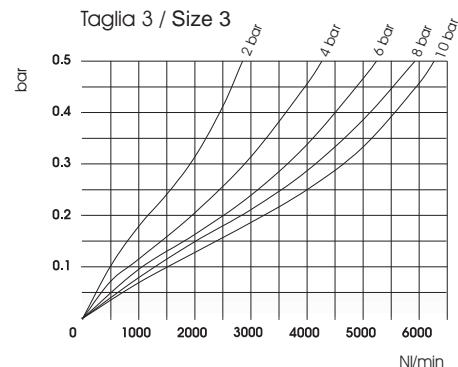
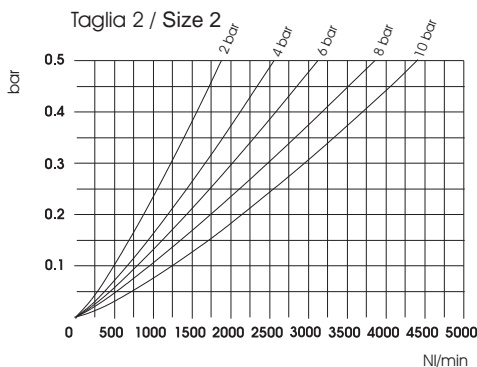
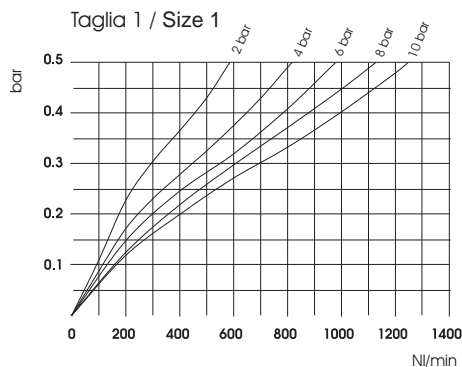

COMPONENTI / COMPONENTS

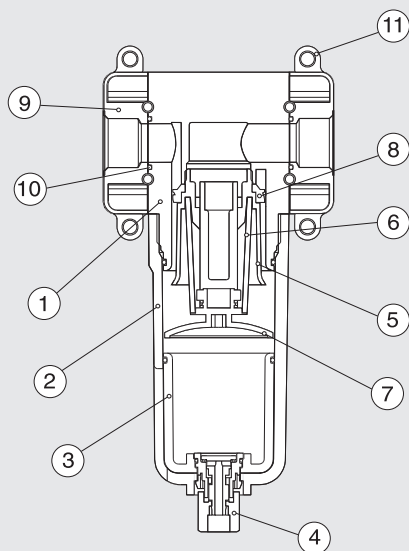

1	corpo / body	tecnopolimero / technopolymer
2	tazza / bowl	tecnopolimero / technopolymer
3	bicchiere / glass	tecnopolimero / technopolymer
4	scarico condensa / condensate exhaust	tecnopolimero / technopolymer
5	portafiltro / filter ring	tecnopolimero / technopolymer
6	cartuccia filtrante / filtering cartridge	bronzo sinterizzato / sintered bronze
7	deflettore / deflector	tecnopolimero / technopolymer
8	centrifugatore / slinger	tecnopolimero / technopolymer
9	terminale / end part	zama
10	o-ring	NBR
11	elemento fissaggio / fixing element	zama

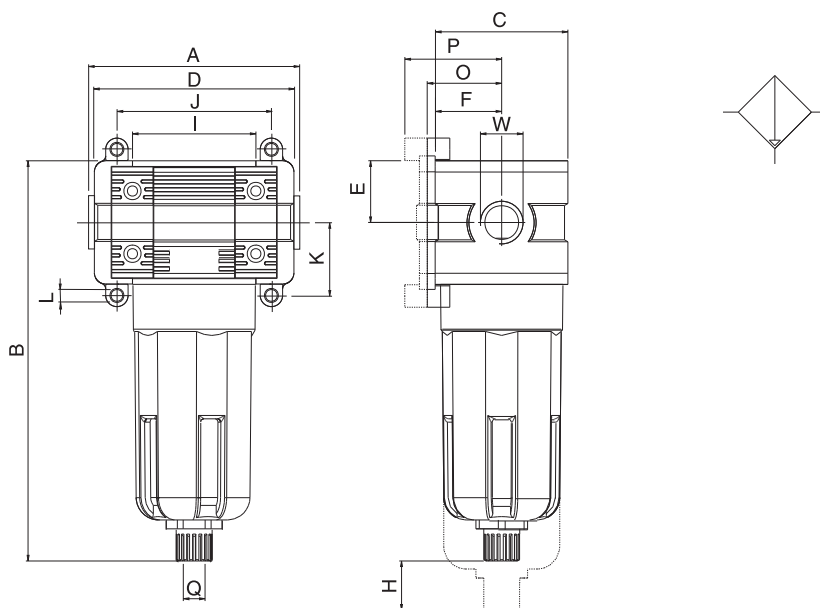

	A	B	C	D	W	E	F	H	I	J	K	L	O	P	Q
taglia 1 / size 1	72	146	45	75,5	1/8 - 1/4 - 3/8	21	22,5	39	43	54	17,25	M4	48,5	55	1/8
taglia 2 / size 2	89	178,5	59	89	1/4 - 3/8 - 1/2	27,5	28,5	48	55	69	22	M5	62,5	69	1/8
taglia 3 / size 3	100	197,5	70	106	1/2 - 3/4 - 1	32,5	35	50	65	79	27	M6	73,5	80	1/8



DATI TECNICI / TECHNICAL DATA

Fluido / Fluid	Aria / Air
Pressione Max / Maximum pressure	15 bar
Temperatura / Temperature	-10 / +50° C
Campo di regolazione / Regulation range	0-2bar 0-4bar 0-8bar standard 0-12bar
Portata a 6 bar con Δp 1bar / 6bar flow rate with Δp 1bar	1=2050NI/min 2=3200NI/min 3=6200NI/min
Attacco manometro / Manometer fastening	1/8

PRODOTTI STANDARD / STANDARD PRODUCTS

CODICE CODE	TAGLIA SIZE	FILETTO THREAD	REGOLAZIONE REGULATION	PORTATA FLOW RATE
XR1230	1	1/4	0-8bar	2050NI/min
XR1330	1	3/8	0-8bar	2050NI/min
XR2330	2	3/8	0-8bar	3200NI/min
XR2430	2	1/2	0-8bar	3200NI/min
XR3530	3	3/4	0-8bar	6200NI/min
XR3630	3	1"	0-8bar	6200NI/min

CHIAVE DI CODIFICA / KEY TO TYPE NUMBER

XR 0,0,0,0

TAGLIA / SIZE

1=TAGLIA 1 / SIZE 1
2=TAGLIA 2 / SIZE 2
3=TAGLIA 3 / SIZE 3

FILETTO / THREAD

1=G 1/8 (TAGLIA 1)
2=G 1/4 (TAGLIA 1)
3=G 3/8 (TAGLIA 1)

2=G 1/4 (TAGLIA 2)
3=G 3/8 (TAGLIA 2)
4=G 1/2 (TAGLIA 2)

4=G 1/2 (TAGLIA 3)
5=G 3/4 (TAGLIA 3)
6=G 1" (TAGLIA 3)

CAMPO DI REGOLAZIONE
REGULATION RANGE

1=0-2bar
2=0-4bar
3=0-8bar
4=0-12bar

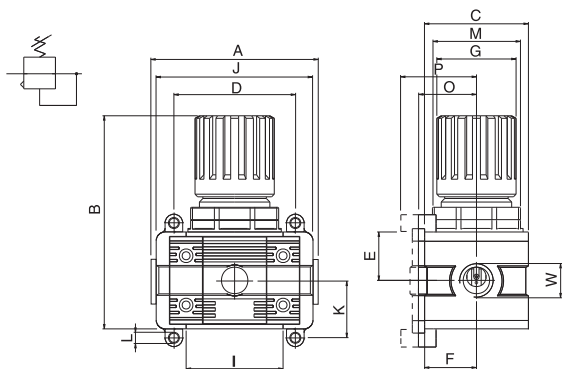

	1	2	3
A	72	89	100
B	97	121	140,5
C	45	59	70
D	75,5	89	106 106 111
W	1/8 - 1/4 - 3/8	1/4 - 3/8 - 1/2	1/2 - 3/4 - 1"
E	21	27,5	32,5
F	22,5	28,5	35
G	36	45	50,5
H	39	48	50
I	43	55	65
J	54	69	79
K	26	32,5	38
L	Ø X M4	Ø X M5	Ø X M6
O	48,5	62,5	73,5
P	55	69	80

COMPONENTI / COMPONENTS

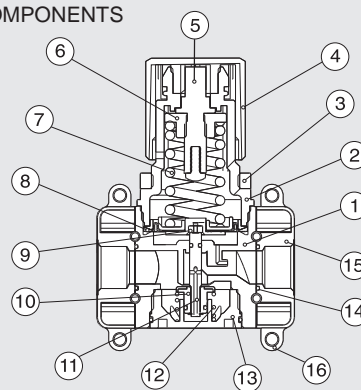

1	corpo / body	tecnopolimero / technopolymer
2	campana / bell	tecnopolimero / technopolymer
3	ghiera di fissaggio / fixing nut	tecnopolimero / technopolymer
4	manopola / knob	tecnopolimero / technopolymer
5	vite di registro / register screw	ottone / brass
6	chiocciola / female screw	ottone / brass
7	molla di registro / register spring	acciaio / steel
8	membrana / membrane	
9	guarnizione / seal	NBR
10	otturatore / shutter	NBR
11	asta / rod	ottone / brass
12	molla / spring	acciaio inox / stainless steel
13	tappo / plug	tecnopolimero / technopolymer
14	o-ring	NBR
15	terminale / end part	zama / zama
16	elemento di fissaggio / fixing element	zama / zama



DATI TECNICI / TECHNICAL DATA

Fluido / Fluid	Aria / Air		
Pressione Max / Maximum pressure	15 bar		
Temperatura / Temperature	-10 / +50° C		
Grado di filtrazione / Filtration grade	5 - 20 - 50µm		
Portata a 6 bar con Δp 1 bar / 6bar flow rate with Δp 1bar	1 = 1650 NI/min	2 = 300NI/min	3 = 4500NI/min
Capacità tazza / Bowl capacity	1 = 22cm ³	2 = 46cm ³	3 = 89,5cm ³
Campo di regolazione / Regulation range	0-2bar	0-4bar	0-8bar standard 0-12bar
Viti per fissaggio / Wall clamping screws	1 = M4X14	2 = M5X18	3 = M6X20

PRODOTTI STANDARD / STANDARD PRODUCTS

CODICE CODE	TAGLIA SIZE	FILETTO THREAD	FILTRAZIONE FILTRATION	PORTATA FLOW RATE	REGOLAZIONE REGULATION	SCARICO EXHAUST
XP12231	1	1/4	20µm	1650NI/min	0 - 8bar	S/M
XP13231	1	3/8	20µm	1650NI/min	0 - 8bar	S/M
XP23231	2	3/8	20µm	3000NI/min	0 - 8bar	S/M
XP24231	2	1/2	20µm	3000NI/min	0 - 8bar	S/M
XP24232	2	1/2	20µm	3000NI/min	0 - 8bar	A
XP35231	3	3/4	20µm	4500NI/min	0 - 8bar	S/M
XP36231	3	1"	20µm	4500NI/min	0 - 8bar	S/M
XP36232	3	1"	20µm	4500NI/min	0 - 8bar	A

S/M: Semiautomatico Manuale / Semi automatic Manual
A: Automatico / Automatic

CHIAVE DI CODIFICA / KEY TO TYPE NUMBER

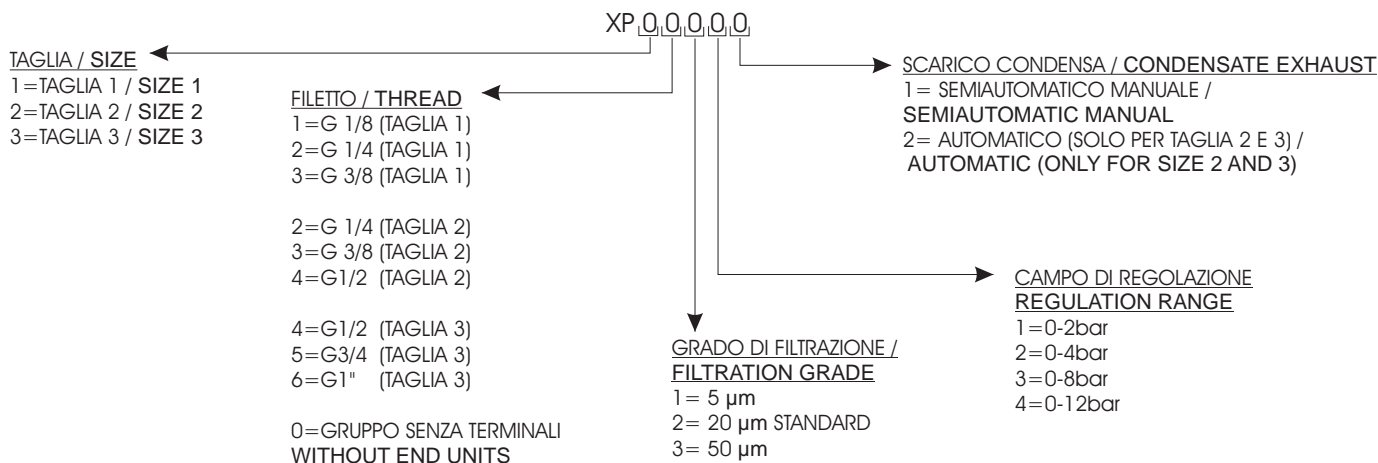

CARATTERISTICHE DI FLUSSO / FLOW CHARACTERISTICS

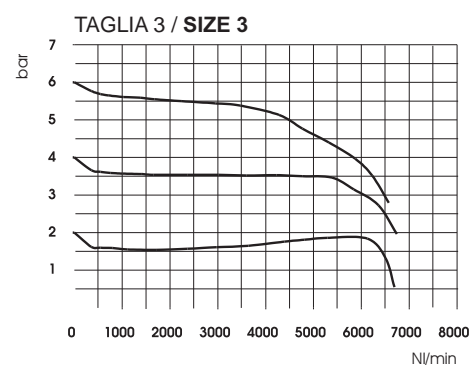
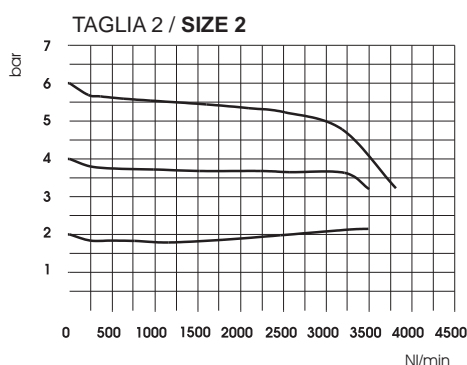
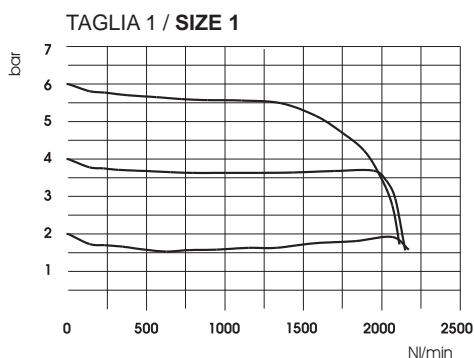

COMPONENTI / COMPONENTS

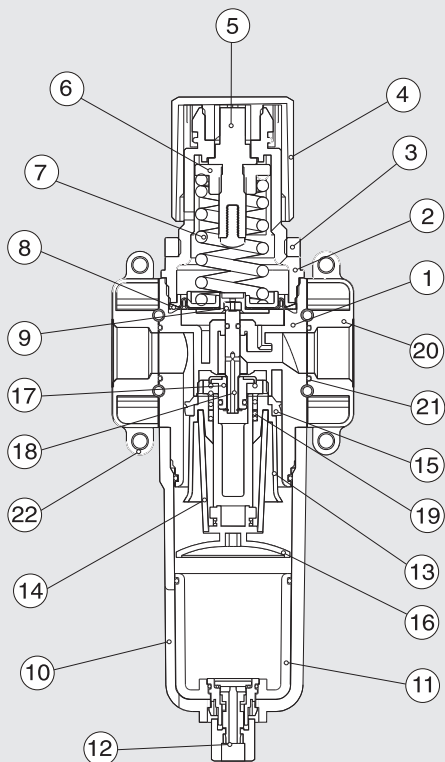

1	corpo / body	tecnopolimero / technopolymer
2	campana / bell	tecnopolimero / technopolymer
3	ghiera di fissaggio / fixing nut	tecnopolimero / technopolymer
4	manopola / knob	tecnopolimero / technopolymer
5	vite di registro / register screw	ottone / brass
6	chiocciola / female screw	ottone / brass
7	molla di registro / register spring	acciaio / steel
8	membrana / membrane	
9	guarnizione / seal	NBR
10	tazza / bowl	tecnopolimero / technopolymer
11	bicchiere / glass	tecnopolimero / technopolymer
12	scarico condensa / condensate exhaust	tecnopolimero / technopolymer
13	portafiltro / filter ring	tecnopolimero / technopolymer
14	cartuccia filtrante / filtering cartridge	bronzo sinterizzato / sintered bronze
15	centrifugatore / slinger	tecnopolimero / technopolymer
16	deflettore / deflector	tecnopolimero / technopolymer
17	otturatore / shutter	NBR
18	asta / rod	ottone / brass
19	molla / spring	acciaio inox / stainless steel
20	terminale / end part	zama / zama
21	o-ring	NBR
22	elemento / fixing element	zama / zama

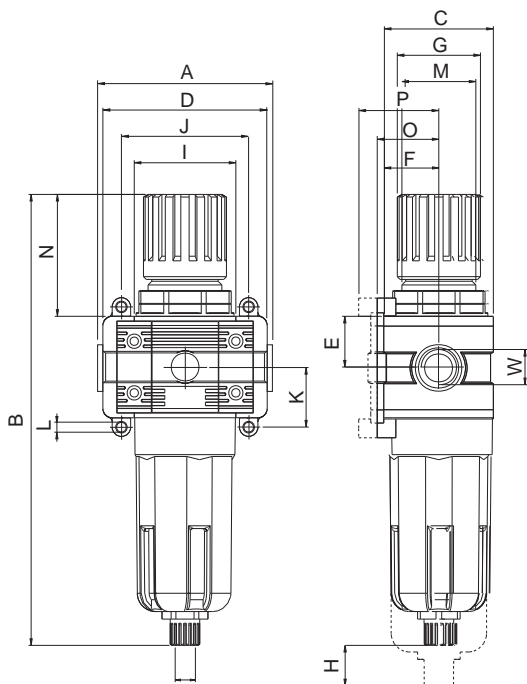

	A	B	C	D	W	E	F	G	H	I	J	K	L	M	N	O	P	Q
taglia 1 / size 1	72	198	45	75,5	1/8 - 1/4 - 3/8	21	22,5	36	39	43	54	26	M4	M32	52	48,5	55	1/8
taglia 2 / size 2	89	244,5	59	89	1/4 - 3/8 - 1/2	27,5	28,5	45	48	55	69	32,5	M5	M40	66	62,5	69	1/8
taglia 3 / size 3	100	273	70	106	1/2 - 3/4 - 1	32,5	35	50,5	50	65	79	38	M6	M47	75,5	73,5	80	1/8



DATI TECNICI / TECHNICAL DATA

Fluido / Fluid	Aria / Air		
Pressione Max / Maximum pressure	15 bar		
Temperatura / Temperature	-10 / +50° C		
Grado di filtrazione / Filtration grade	5 - 20 - 50µm		
Portata a 6 bar con Δp 1bar / 6bar flow rate with Δp 1bar	1=2600 NI/min	2=5600NI/min	3=8200NI/min
Capacità tazza / Bowl capacity	1=22cm ³	2=46cm ³	3=89,5cm ³
Viti per fissaggio / Wall clamping screws	1=M4X14	2=M5X18	3=M6X20
Olio consigliato / Recommended oil	Classe ISO 22 a Norma ISO 3448		

PRODOTTI STANDARD / STANDARD PRODUCTS

CODICE CODE	TAGLIA SIZE	FILETTO THREAD	PORTATA FLOW RATE	CARICO OLIO OIL LOAD
XL1210	1	1/4	2600NI/min	M
XL1310	1	3/8	2600NI/min	M
XL1320	1	3/8	2600NI/min	A
XL2310	2	3/8	5600NI/min	M
XL2410	2	1/2	5600NI/min	M
XL2420	2	1/2	5600NI/min	A
XL3510	3	3/4	8200NI/min	M
XL3610	3	1"	8200NI/min	M
XL3620	3	1"	8200NI/min	A
XL3630	3	1"	8200NI/min	M2L

M: Manuale / Manual
A: Automatico a depressione / Automatic to vacuum-operated
M2L: Manuale con sensore a due livelli / Two steps sensor Manual

CHIAVE DI CODIFICA / KEY TO TYPE NUMBER

XL 0 0 0 0

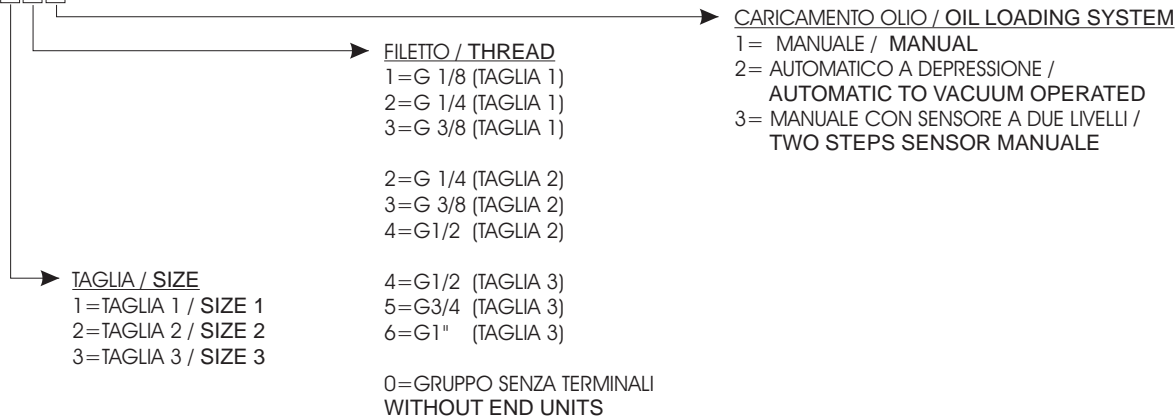

CARATTERISTICHE DI FLUSSO / FLOW CHARACTERISTICS

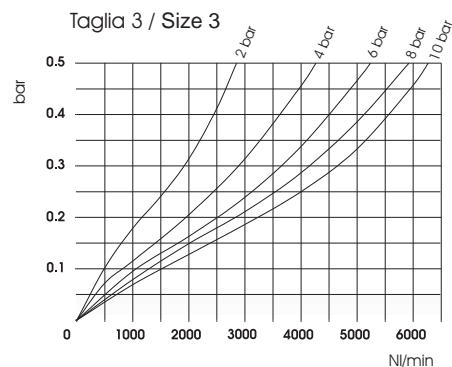
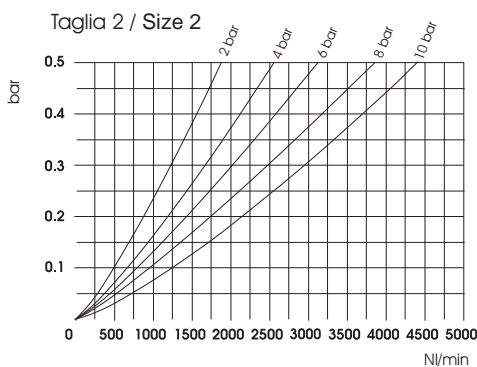
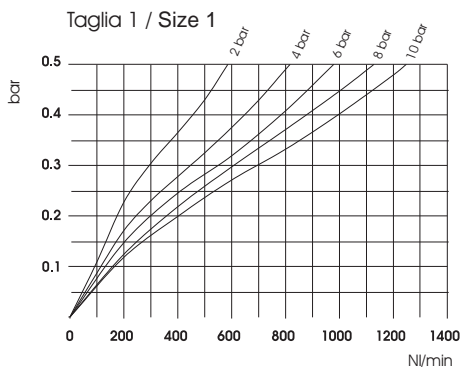

COMPONENTI / COMPONENTS

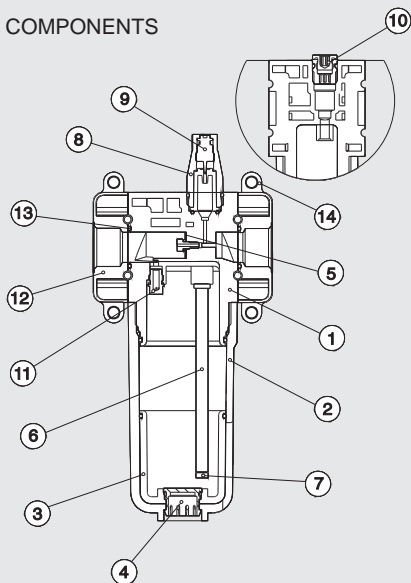

1	corpo / body	tecnopolimero / technopolymer
2	tazza / bowl	tecnopolimero / technopolymer
3	bicchiere / glass	tecnopolimero / technopolymer
4	tappo / plug	tecnopolimero / technopolymer
5	membrana / membrane	
6	tubo / tube	PA11
7	filtrino / small filter	
8	cupola / dome	tecnopolimero / technopolymer
9	spillo / pin	ottone / brass
10	tappo / plug	ottone / brass
11	diffusore / diffuser	ottone / brass
12	terminale / end part	zama / zama
13	o-ring	NBR
14	elemento di fissaggio / fixing part	zama / zama

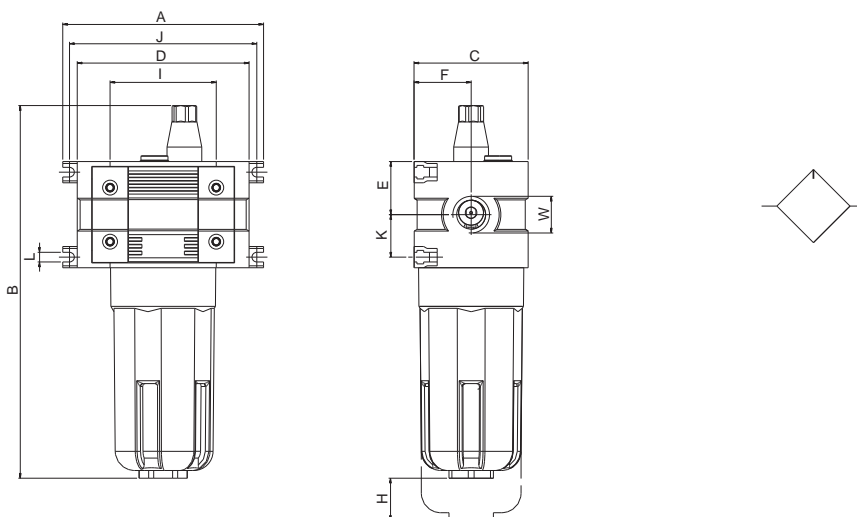

	A	B	C	D	W	E	F	H	I	J	K	L	M	O	P
taglia 1 / size 1	72	162	45	75,5	1/8 - 1/4 - 3/8	21	22,5	39	43	18,5	26	M4	29	18,5	55
taglia 2 / size 2	89	195	59	89	1/4 - 3/8 - 1/2	27,5	28,5	48	55	69	32,5	M5	29	62,5	69
taglia 3 / size 3	100	214	70	106	1/2 - 3/4 - 1	32,5	35	50	65	79	38	M6	29	73,5	80

SCHEMI ELETTRICI CARICAMENTO MANUALE OLIO A DUE LIVELLI / ELECTRICAL DATA OIL LOADING SYSTEM TWO STEPS SENSOR MANUAL

Lunghezza cavo / Cable length: 1500 mm

Corrente / Current: 0.5 A

Tensione / Voltage: <24V

Potenziale / Capacity: 10W

segnale al livello minimo
minimum level

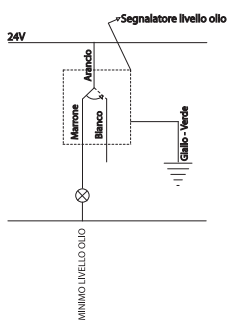

segnale al livello massimo
maximum level

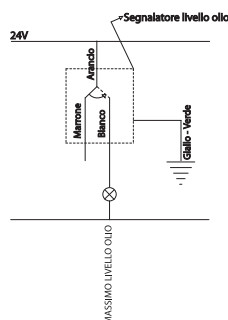

segnale livello olio al minimo e
al massimo
minimum and maximum level oil

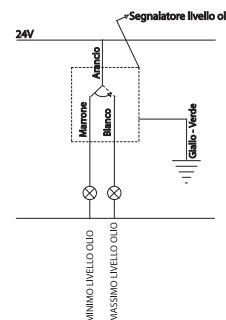

**FILTROREGOLATORE + LUBRIFICATORE (FR+L)
FILTERREGULATOR+LUBRICATOR (FR+L)**



DATI TECNICI / TECHNICAL DATA

Fluido / Fluid	Aria / Air		
Pressione Max / Maximum pressure	15 bar		
Temperatura / Temperature	-10 / +50° C		
Grado di filtrazione / Filtration grade	5 - 20 - 50µm		
Portata a 6 bar con Δp 1bar / 6bar flow rate with Δp 1bar	1=1100NI/min	2=2500NI/min	3=4300NI/min
Capacità tazza / Bowl capacity	1=22cm ³	2=46cm ³	3=89,5cm ³
Campo di regolazione / Regulation range	0-2bar	0-4bar	0-8bar standard 0-12bar
Viti per fissaggio / Wall clamping screws	1=M4X14	2=M5X18	3=M6X20

PRODOTTI STANDARD / STANDARD PRODUCTS

CODICE CODE	TAGLIA SIZE	FILETTO THREAD	FILTRAZIONE FILTRATION	PORTATA FLOW RATE	REGOLAZIONE REGULATION	SCARICO EXHAUST
XS12231	1	1/4	20µm	1100NI/min	0 - 8bar	S/M
XS13231	1	3/8	20µm	1100NI/min	0 - 8bar	S/M
XS23231	2	3/8	20µm	2500NI/min	0 - 8bar	S/M
XS24231	2	1/2	20µm	2500NI/min	0 - 8bar	S/M
XS24232	2	1/2	20µm	2500NI/min	0 - 8bar	A
XS35231	3	3/4	20µm	4300NI/min	0 - 8bar	S/M
XS36231	3	1"	20µm	4300NI/min	0 - 8bar	S/M
XS36232	3	1"	20µm	4300NI/min	0 - 8bar	A

CHIAVE DI CODIFICA / KEY TO TYPE NUMBER

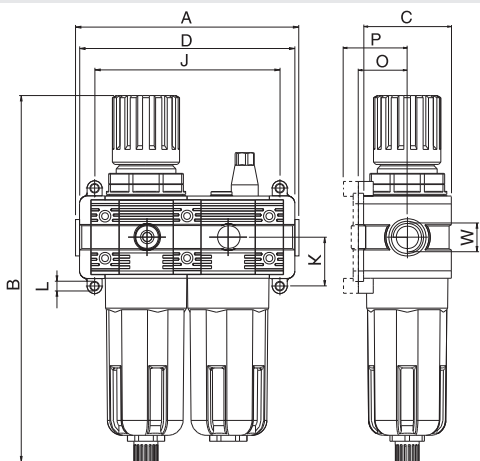
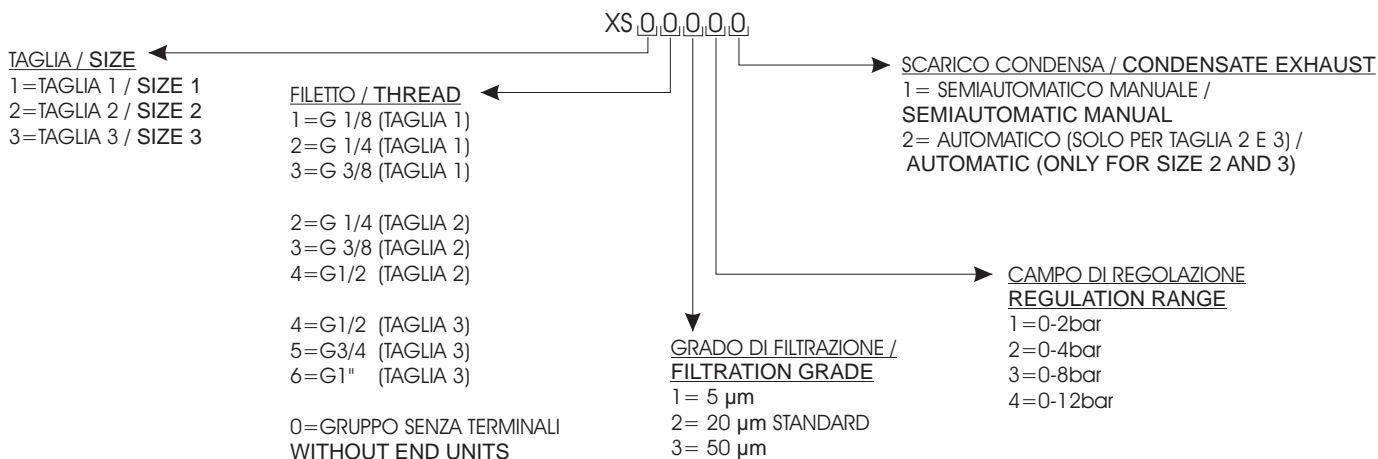

	taglia / size		
	1	2	3
A	129	159	180
B	198	244,5	273
C	45	59	70
D	119	144	171 171 176
W	1/8 - 1/4 - 3/8	1/4 - 3/8 - 1/2	1/2 - 3/4 - 1"
J	124,5	152	174
K	17,25	22	27
L	Ø X M4	Ø X M5	Ø X M6
O	48,5	62,5	73,5
P	55	69	80



DATI TECNICI / TECHNICAL DATA

Fluido / Fluid	Aria / Air		
Pressione Max / Maximum pressure	15 bar		
Temperatura / Temperature	-10 / +50° C		
Grado di filtrazione / Filtration grade	5 - 20 - 50µm		
Portata a 6 bar con Δp 1bar / 6bar flow rate with ?p 1bar	1=1000 NI/min	2=2400NI/min	3=4250NI/min
Capacità tazza / Bowl capacity	1=22cm ³	2=46cm ³	3=89,5cm ³
Campo di regolazione / Regulation range	0-2bar	0-4bar	0-8bar standard 0-12bar
Viti per fissaggio / Wall clamping screws	1=M4X14	2=M5X18	3=M6X20

PRODOTTI STANDARD / STANDARD PRODUCTS

CODICE CODE	TAGLIA SIZE	FILETTO THREAD	FILTRAZIONE FILTRATION	PORTATA FLOW RATE
XT122311	1	1/4	20µm	1000NI/min
XT132311	1	3/8	20µm	1000NI/min
XT232311	2	3/8	20µm	2400NI/min
XT242311	2	1/2	20µm	2400NI/min
XT352311	3	3/4	20µm	4250NI/min
XT362311	3	1"	20µm	4250NI/min

CHIAVE DI CODIFICA / KEY TO TYPE NUMBER

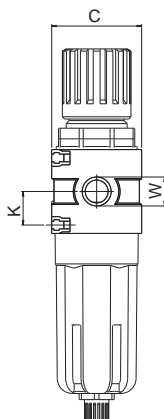
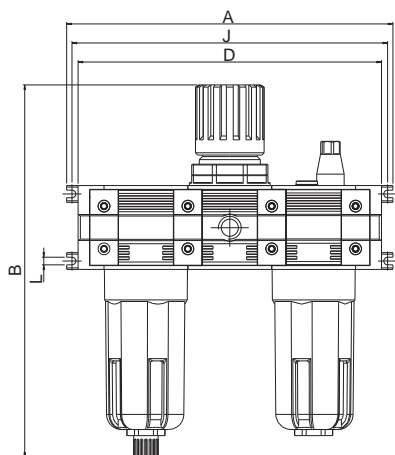
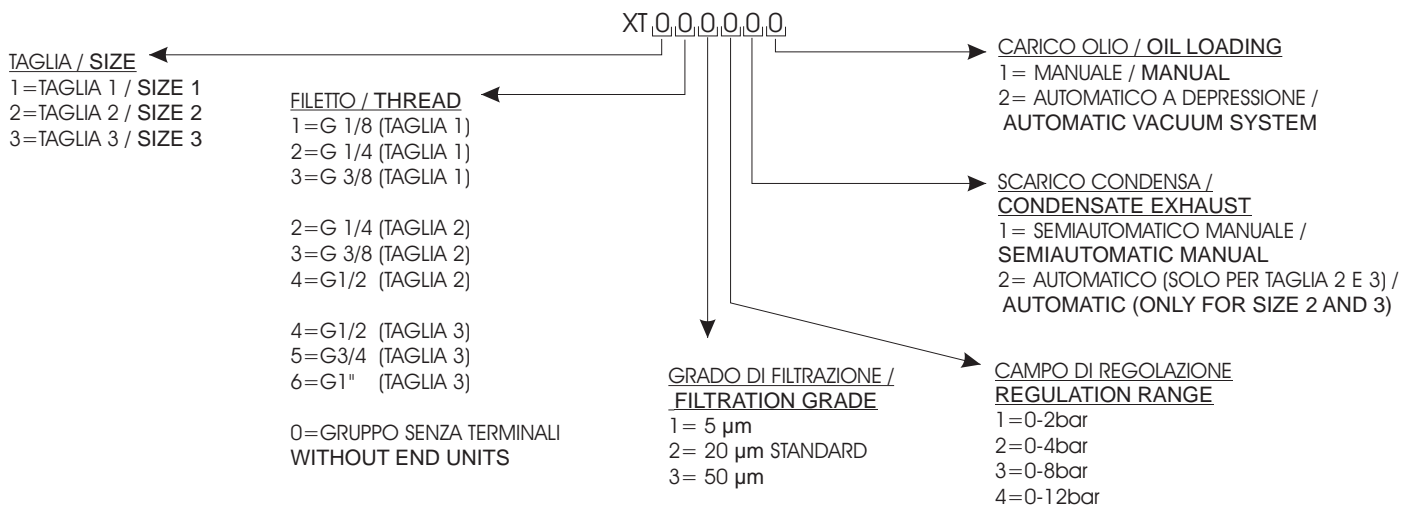

	taglia / size		
	1	2	3
A	158	199	230
B	198	244,5	273
C	45	59	70
D	161,5	199	236 236 241
W	1/8 - 1/4 - 3/8	1/4 - 3/8 - 1/2	1/2 - 3/4 - 1"
J	140	179	209
K	26	32,5	38
L	Ø X M4	Ø X M5	Ø X M6
O	48,5	62,5	73,5
P	55	69	80

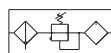

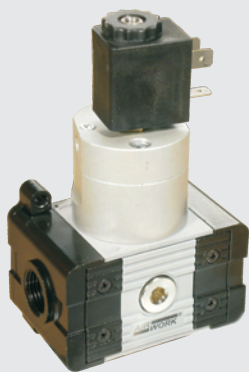

DATI TECNICI / TECHNICAL DATA

Fluido / Fluid	Aria / Air
Pressione Max / Maximum pressure	15 bar
Temperatura / Temperature	-10 / +50° C
Portata a 6 bar con Δp 1bar / 6bar flow rate with Δp 1bar	1=1850 NI/min 2=3000NI/min 3=5200NI/min
Viti per fissaggio / Wall clamping screws	1=M4X14 2=M5X18 3=M6X20
Solenoido / Solenoid	24V DC 3W - 220V AC 5VA

PRODOTTI STANDARD / STANDARD PRODUCTS

CODICE CODE	TAGLIA SIZE	FILETTO THREAD	COMANDO DRIVE
XA1300	1	3/8	EP
XA2300	2	3/8	EP
XA2400	2	1/2	EP
XA3500	3	3/4	EP
XA3600	3	1"	EP

EP: Elettropneumatico (senza bobina) / Electropneumatic (without coil)

TAGLIA 1 / SIZE 1

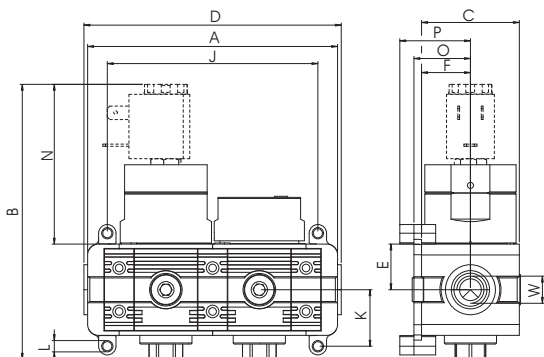

	1
A	115
B	126,5
C	45
D	118,4
W	1/8 - 1/4 - 3/8
E	21
F	22,5
J	97
K	26
L	Ø X M5
N	73,5
O	26
P	32,5

TAGLIA 2 - 3 / SIZE 2 - 3

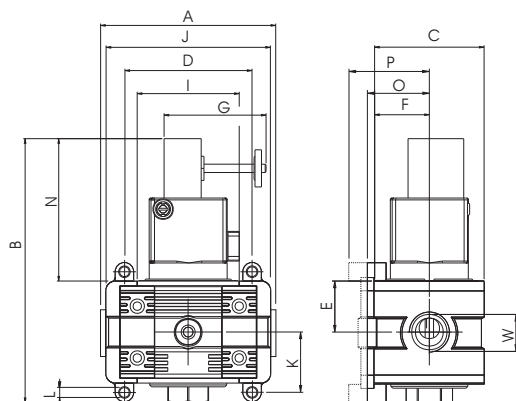

	2	3
A	104	115
B	142	131,5
C	59	70
D	89	106 106 111
W	1/4 - 3/8 - 1/2	1/2 - 3/4 - 1"
E	27,5	32,5
F	28,5	35
G	55,5	55,5
I	55	65
J	97	109
K	22	27
L	Ø X M5	Ø X M5
N	76,5	76,5

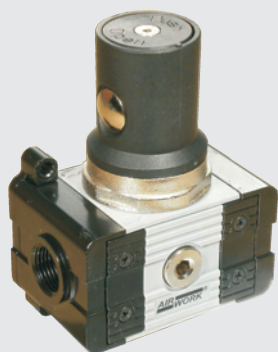

DATI TECNICI / TECHNICAL DATA

Fluido / Fluid	Aria / Air
Pressione Max / Maximum pressure	15 bar
Temperatura / Temperature	-10 / +50° C
Portata a 6 bar con Δp 1bar / 6bar flow rate with Δp 1bar	1=1850 NI/min 2=3000NI/min 3=5200NI/min
Viti per fissaggio / Wall clamping screws	1=M4X14 2=M5X18 3=M6X20
Solenoide / Solenoid	24V DC 3W - 220V AC 5VA

PRODOTTI STANDARD / STANDARD PRODUCTS

CODICE CODE	TAGLIA SIZE	FILETTO THREAD	PORTATA FLOW RATE	COMANDO DRIVE
XV121	1	1/4	1850NI/min	M
XV131	1	3/8	1850NI/min	M
XV132	1	3/8	1850NI/min	EP
XV133	1	3/8	1850NI/min	P
XV231	2	3/8	3000NI/min	M
XV241	2	1/2	3000NI/min	M
XV242	2	1/2	3000NI/min	EP
XV243	2	1/2	3000NI/min	P
XV351	3	3/4	5200NI/min	M
XV361	3	1"	5200NI/min	M
XV362	3	1"	5200NI/min	EP
XV363	3	1"	5200NI/min	P

M: Manuale / Manual

P: Pneumatico / Pneumatic

EP: Elettropneumatico (senza bobina) / Electropneumatic (without coil)

MANUALE / MANUAL

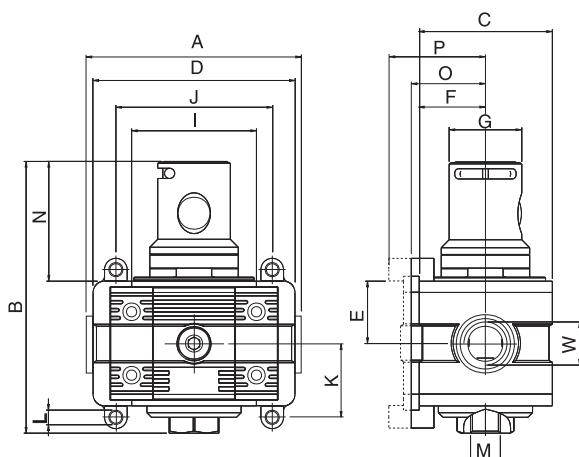

	taglia / size		
	1	2	3
A	72	89	100
B	105,5	119,5	131,5
C	45	59	70
D	75,5	89	106 106 111
W	1/8 - 1/4 - 3/8	1/4 - 3/8 - 1/2	1/2 - 3/4 - 1"
E	21	27,5	32,5
F	22,5	28,5	35
G	32	32	32
I	43	55	65
J	54	69	79
K	26	32,5	38
L	Ø X M4	Ø X M5	Ø X M6
M	1/8	1/4	3/8
N	52,5	52,5	52,5
O	48,5	62,5	73,5
P	55	69	80

PNEUMATICO / PNEUMATIC

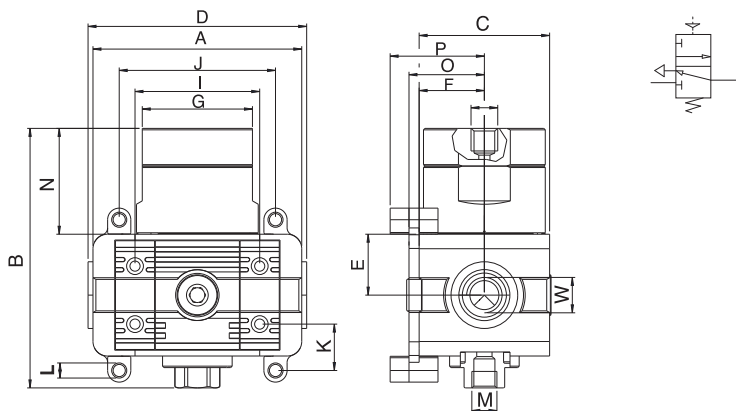

	taglia / size		
	1	2	3
A	72	89	100
B	89,5	100,5	108
B1	126,5	137,5	144,9
C	45	59	70
D	75,5	89	106 106 111
W	1/8 - 1/4 - 3/8	1/4 - 3/8 - 1/2	1/2 - 3/4 - 1"
E	21	27,5	32,5
F	22,5	28,5	35
G	38	38	38
I	43	55	65
J	54	69	79
K	16	32,5	38
L	Ø X M4	Ø X M5	Ø X M6
M	1/8	1/4	3/8
N	36,5	32,7	29
N1	73,5	69,6	65,9
O	26	33	38,5
P	32,5	39,5	45
Q	1/8	1/8	1/8

ELETTROPNEUMATICO / ELETTROPNEUMATIC

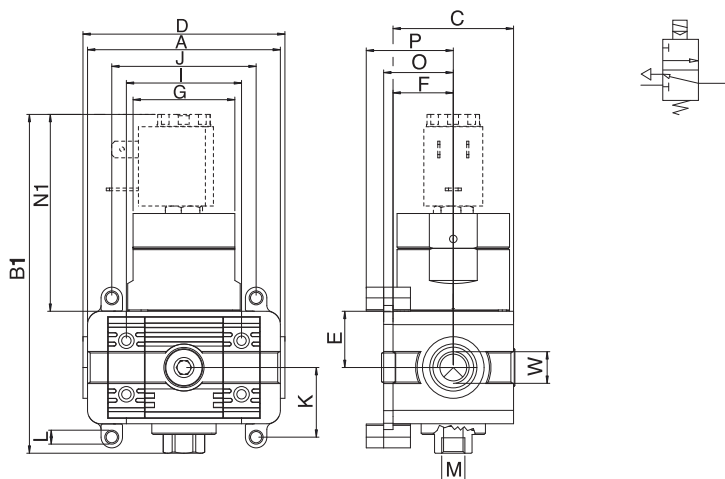

	taglia / size		
	1	2	3
A	72	89	100
B	89,5	100,5	108
B1	126,5	137,5	144,9
C	45	59	70
D	75,5	89	106 106 111
W	1/8 - 1/4 - 3/8	1/4 - 3/8 - 1/2	1/2 - 3/4 - 1"
E	21	27,5	32,5
F	22,5	28,5	35
G	38	38	38
I	43	55	65
J	54	69	79
K	16	32,5	38
L	Ø X M4	Ø X M5	Ø X M6
M	1/8	1/4	3/8
N	36,5	32,7	29
N1	73,5	69,6	65,9
O	26	33	38,5
P	32,5	39,5	45
Q	1/8	1/8	1/8



DATI TECNICI / TECHNICAL DATA

Fluido / Fluid	Aria / Air		
Pressione Max / Maximum pressure	15 bar		
Temperatura / Temperature	-10 / +50° C		
Grado di filtrazione / Filtration grade	5 - 20 - 50µm		
Portata a 6 bar con Δp 1 bar / 6bar flow rate with Δp 1bar	1=1350 NI/min	2=3200NI/min	3=5000NI/min
Capacità tazza / Bowl capacity	1=22cm3	2=46cm3	3=89,5cm3
Viti per fissaggio / Wall clamping screws	1=M4X14	2=M5X18	3=M6X20

PRODOTTI STANDARD / STANDARD PRODUCTS

CODICE CODE	TAGLIA SIZE	FILETTO THREAD	FILTRAZIONE FILTRATION	PORTATA FLOW RATE
XO122011	1	1/4	20µm	1350NI/min
XO132011	1	3/8	20µm	1350NI/min
XO232011	2	3/8	20µm	3200NI/min
XO242011	2	1/2	20µm	3200NI/min
XO352011	3	3/4	20µm	5000NI/min
XO362011	3	1"	20µm	5000NI/min

S/M: Semiautomatico Manuale / Semi automatic Manual
Δ: Automatico / Automatic

CHIAVE DI CODIFICA / KEY TO TYPE NUMBER

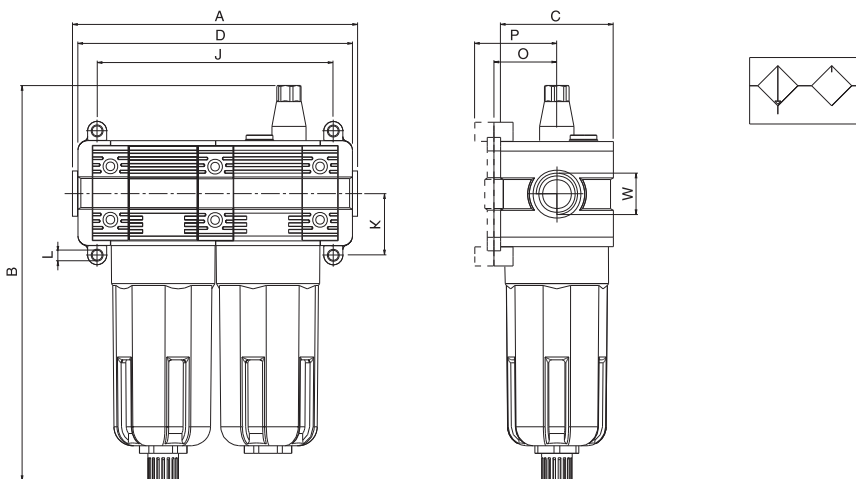
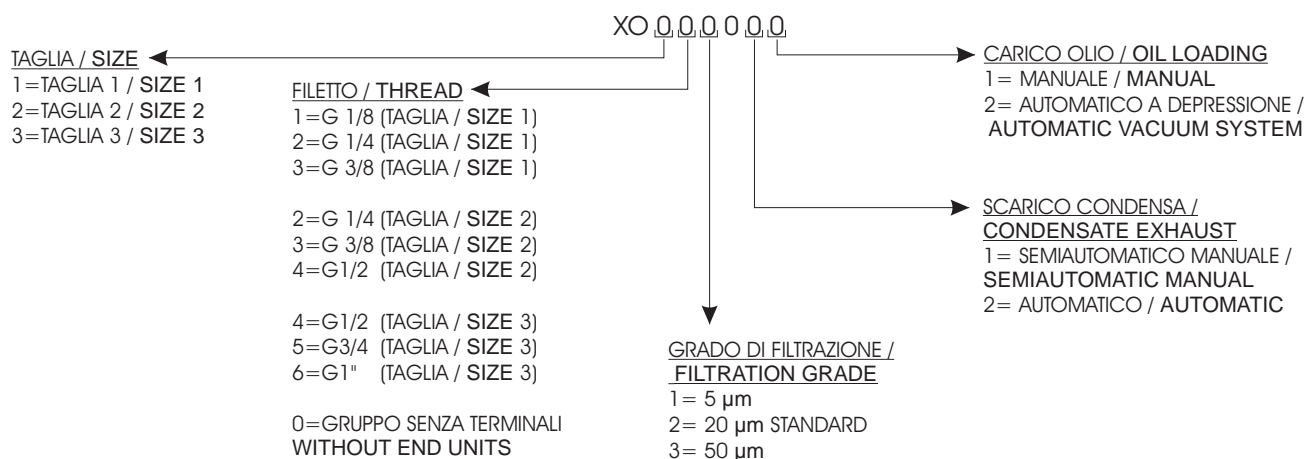

	A	B	C	D	W	J	K	L	O	P
taglia 1 / size 1	115	175	45	118,5	1/8 - 1/4 - 3/8	97	26	M4	48,5	55
taglia 2 / size 2	144	207,5	59	144	1/4 - 3/8 - 1/2	124	32,5	M5	62,5	69
taglia 3 / size 3	165	226,5	70	171	1/2 - 3/4 - 1	144	38	M6	73,5	80

**VALVOLA + FILTROREGOLATORE + LUBRIFICATORE (V+FR+L)
VALVE + FILTERREGULATOR + LUBRICATOR (V+FR+L)**



DATI TECNICI / TECHNICAL DATA

Fluido / Fluid	Aria / Air		
Pressione Max / Maximum pressure	15 bar		
Temperatura / Temperature	-10 / +50° C		
Portata a 6 bar con Δp 1 bar / 6bar flow rate with Δp 1bar	1=800 NI/min	2=2100NI/min	3=3500NI/min
Viti per fissaggio / Wall clamping screws	1=M4X14	2=M5X18	3=M6X20
Capacità tazza / Bowl capacity	1=22cm ³	2=46cm ³	3=89,5cm ³

PRODOTTI STANDARD / STANDARD PRODUCTS

CODICE CODE	TAGLIA SIZE	FILETTO THREAD	FILTRAZIONE FILTRATION	PORTATA FLOW RATE	REGOLAZIONE REGULATION
XM122311	1	1/4	20µm	800NI/min	0 - 8bar
XM132311	1	3/8	20µm	800NI/min	0 - 8bar
XM232311	2	3/8	20µm	2100NI/min	0 - 8bar
XM242311	2	1/2	20µm	2100NI/min	0 - 8bar
XM352311	3	3/4	20µm	3500NI/min	0 - 8bar
XM362311	3	1"	20µm	3500NI/min	0 - 8bar

CHIAVE DI CODIFICA / KEY TO TYPE NUMBER

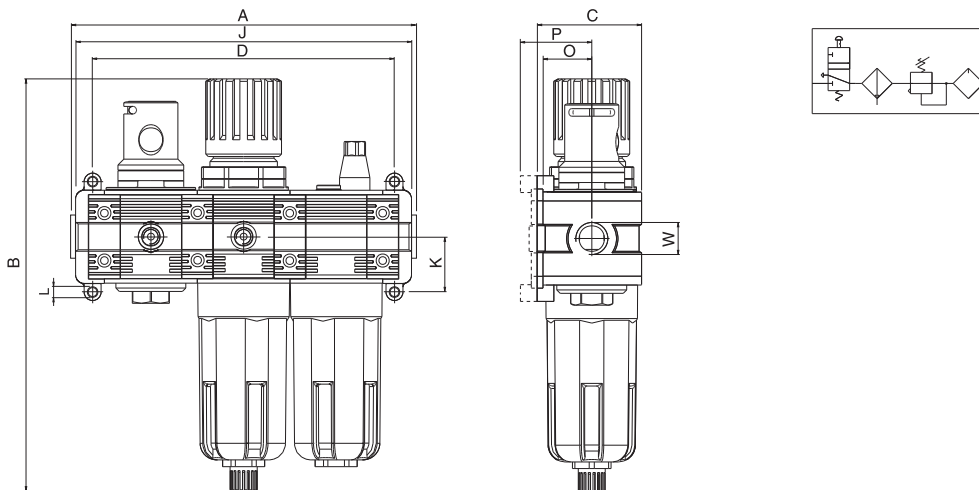
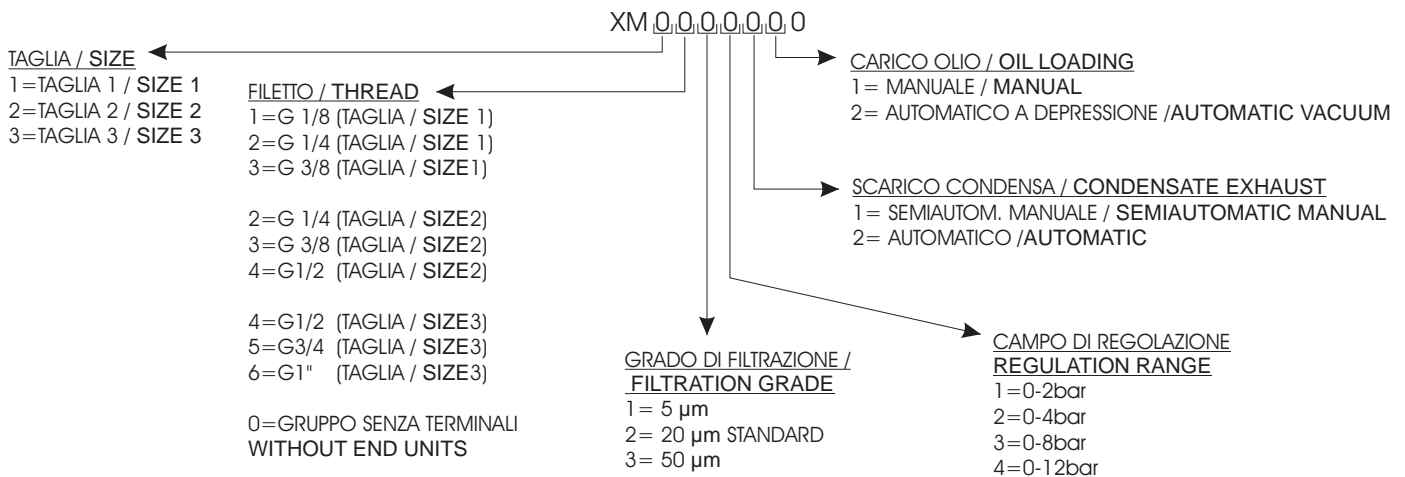

	A	B	C	D	W	J	K	L	O	P
taglia 1 / size 1	115	198	45	118,5	1/8 - 1/4 - 3/8	97	26	M4	48,5	55
taglia 2 / size 2	144	244,5	59	199	1/4 - 3/8 - 1/2	124	32,5	M5	62,5	69
taglia 3 / size 3	165	273	70	236	1/2 - 3/4 - 1	144	38	M6	73,5	80



DATI TECNICI / TECHNICAL DATA

Fluido / Fluid	Aria / Air		
Pressione Max / Maximum pressure	15 bar		
Temperatura / Temperature	-10 / +50° C		
Grado di filtrazione / Filtration grade	5 - 20 - 50µm		
Portata a 6 bar con Δp 1bar / 6bar flow rate with Δp 1bar	1=1000 NI/min	2=2200NI/min	3=3900NI/min
Capacità tazza / Bowl capacity	1=22cm ³	2=46cm ³	3=89,5cm ³
Campo di regolazione / Regulation range	0-2bar	0-4bar	0-8bar standard 0-12bar
Viti per fissaggio / Wall clamping screws	1=M4X14	2=M5X18	3=M6X20

PRODOTTI STANDARD / STANDARD PRODUCTS

CODICE CODE	TAGLIA SIZE	FILETTO THREAD	FILTRAZIONE FILTRATION	PORTATA FLOW RATE
XN122311	1	1/4	20µm	1000NI/min
XN132311	1	3/8	20µm	1000NI/min
XN232311	2	3/8	20µm	2200NI/min
XN242311	2	1/2	20µm	2200NI/min
XN352311	3	3/4	20µm	3900NI/min
XN362311	3	1"	20µm	3900NI/min

S/M: Semiautomatico Manuale /
Semi automatic Manual
A: Automatico / Automatic

CHIAVE DI CODIFICA / KEY TO TYPE NUMBER

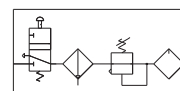
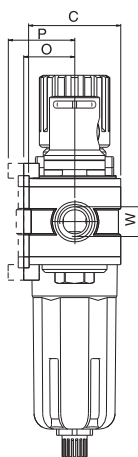
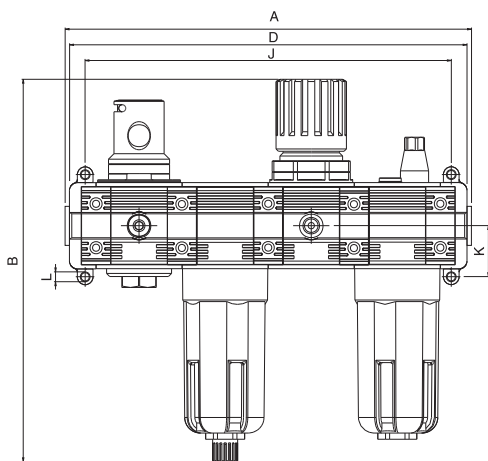
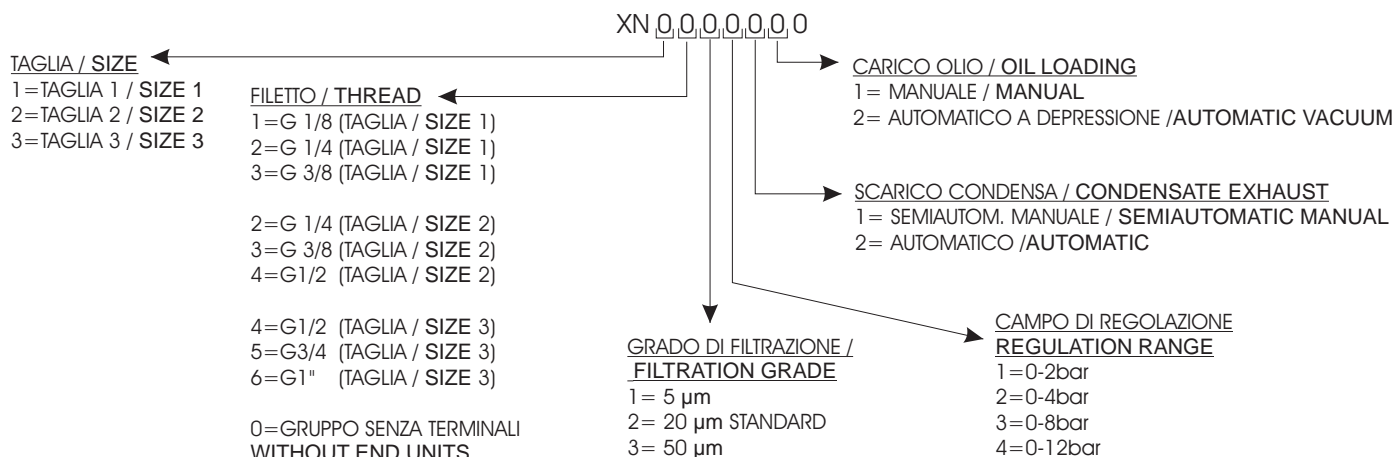

	A	B	C	D	W	J	K	L	O	P
taglia 1 / size 1	201	198	45	204,5	1/8 - 1/4 - 3/8	183	26	M4	48,5	55
taglia 2 / size 2	254	244,5	59	254	1/4 - 3/8 - 1/2	234	32,5	M5	62,5	69
taglia 3 / size 3	295	273	70	301	1/2 - 3/4 - 1	274	38	M6	73,5	80

PIASTRINA DI COLLEGAMENTO / CONNECTION PLATE



CODE	SIZE
XB0100	0
XB0110	1
XB0120	2
XB0130	3

GRUPPO TERMINALI / ENDS UNIT



CODE	SIZE
XB0211	1 1/8
XB0212	1 1/4
XB0213	1 3/8
XB0222	2 1/4
XB0223	2 3/8
XB0224	2 1/2
XB0234	3 1/2
XB0233	3 3/4
XB0236	3 1"

GRUPPO DI COLLEGAMENTO / CONNECTION UNIT



CODE	SIZE
XB0311	1 1/8
XB0312	1 1/4
XB0313	1 3/8
XB0322	2 1/4
XB0323	2 3/8
XB0324	2 1/2
XB0334	3 1/2
XB0333	3 3/4
XB0336	3 1"

GRUPPO PORTAFILTRO / FILTER RING DEVICE



CODE	SIZE
XB0801	0 5 µm
XB0802	0 20 µm
XB0803	0 50 µm
XB0811	1 5 µm
XB0812	1 20 µm
XB0813	1 50 µm
XB0821	2 5 µm
XB0822	2 20 µm
XB0823	2 50 µm
XB0831	3 5 µm
XB0832	3 20 µm
XB0833	3 50 µm

MANOMETRO / MANOMETER



CODE	SIZE
XB1714	D.40 0-12 bar
XB1712	D.40 0-4 bar
XB2114	D.50 0-12 bar
XB2112	D.50 0-4 bar

MOLLA DI REGISTRO / REGISTER SPRING



CODE	SIZE
XB1201	0 0-2 bar
XB1202	0 0-4 bar
XB1203	0 0-8 bar
XB1204	0 0-12 bar
XB1211	1 0-2 bar
XB1212	1 0-4 bar
XB1213	1 0-8 bar
XB1214	1 0-12 bar
XB1221	2 0-2 bar
XB1222	2 0-4 bar
XB1223	2 0-8 bar
XB1224	2 0-12 bar
XB1231	3 0-2 bar
XB1232	3 0-4 bar
XB1233	3 0-8 bar
XB1234	3 0-12 bar

GRUPPO MEMBRANA / MEMBRANE UNIT



CODE	SIZE
XB1800	0
XB1810	1
XB1820	2
XB1830	3

GRUPPO VENTURI / VENTURI UNIT



CODE	SIZE
XB0900	0
XB0910	1
XB0920	2
XB0930	3

GRUPPO DOSATORE OLIO / OIL FEEDING DEVICE



CODE	SIZE
XB1000	0
XB1010	1
XB1020	2
XB1030	3

GRUPPO DI REGOLAZIONE / REGULATING DEVICE



CODE	SIZE
XB1101	0 0-2 bar
XB1102	0 0-4 bar
XB1103	0 0-8 bar
XB1104	0 0-12 bar
XB1111	1 0-2 bar
XB1112	1 0-4 bar
XB1113	1 0-8 bar
XB1114	1 0-12 bar
XB1121	2 0-2 bar
XB1122	2 0-4 bar
XB1123	2 0-8 bar
XB1124	2 0-12 bar
XB1131	3 0-2 bar
XB1132	3 0-4 bar
XB1133	3 0-8 bar
XB1134	3 0-12 bar

GRUPPO TAPPO REGOLATORE / REGULATING PLUG UNIT



CODE	SIZE
XB1300	0
XB1310	1
XB1320	2
XB1330	3

GRUPPO OTTURATORE + FILTRO / SHUTTER + FILTER UNIT



CODE	SIZE
XB1501	0 5 µm
XB1502	0 20 µm
XB1503	0 50 µm
XB1511	1 5 µm
XB1512	1 20 µm
XB1513	1 50 µm
XB1521	2 5 µm
XB1522	2 20 µm
XB1523	2 50 µm
XB1531	3 5 µm
XB1532	3 20 µm
XB1533	3 50 µm

FILTRO SINTERIZZATO / SINTERED FILTER



CODE	SIZE
XB1601	0 5 µm
XB1602	0 20 µm
XB1603	0 50 µm
XB1611	1 5 µm
XB1612	1 20 µm
XB1613	1 50 µm
XB1621	2 5 µm
XB1622	2 20 µm
XB1623	2 50 µm
XB1631	3 5 µm
XB1632	3 20 µm
XB1633	3 50 µm

DISTRIBUTORE D'ARIA / AIR DISTRIBUTOR

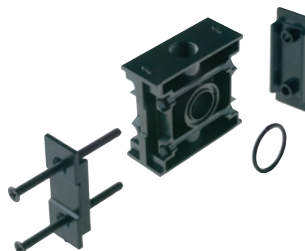

CODE	SIZE
XB1400	0
XB1410	1
XB1420	2
XB1430	3

STAFFA DI FISSAGGIO / CLAMP BRACKET

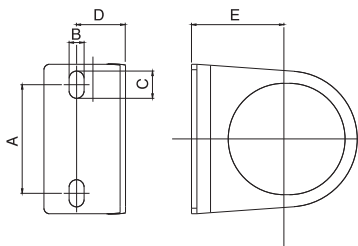

CODE	SIZE	A	B	C	D	E
XB1900	0	21,5	5,5	12	15	31
XB1910	1	28	5,5	10	15	29
XB1920	2	40	5,5	10	18	35
XB1930	3	50	5,5	10	20	39

BOBINA / COIL



CODE	
XB2010	24V DC 3W
XB2020	220V AC 5VA

GRUPPO TAZZA FILTRO / BOWL FOR FILTER UNIT



CODE	SIZE
XB0400	0
XB0410	1
XB0420	2
XB0430	3

GRUPPO TAZZA SCARICO CONDENZA AUTO. /
 BOWL FOR AUTOMATIC CONDENSED EXHAUST



CODE	SIZE
XB0520	2
XB0530	3

GRUPPO TAZZA LUBRIFICATORE / BOWL FOR LUBRICATOR UNIT



CODE	SIZE
XB0600	0
XB0610	1
XB0620	2
XB0630	3

GRUPPO TAZZA CARICAMENTO AUTOMATICO OLIO /
 BOWL FOR AUTOMATIC OIL LOADING SYSTEM



CODE	SIZE
XB0710	1
XB0720	2
XB0730	3

